



COMMUNICATION CONVERTER

WHITEPAPER



SELECTRON

Converting data from any source to your architecture has never been easier and – foremost – securer thanks to SL2-certified Selectron Hardware



Introduction

As defined in the International Standard IEC 61375, the train consist network can be conceptualized based on different network technologies which generally can be classified in two classes: the bus technology and the switched technology.

In the bus technology, multiple end devices are connected to the same data transmission media.

Typical bus protocols in railway environment are MVB (Multifunction Vehicle Bus), CAN, RS-485, RS-422 or HDLC

The switched technology class implements the ethernet protocol to realize the ECN (Ethernet Consist Network) where every end device is connected to a switch.

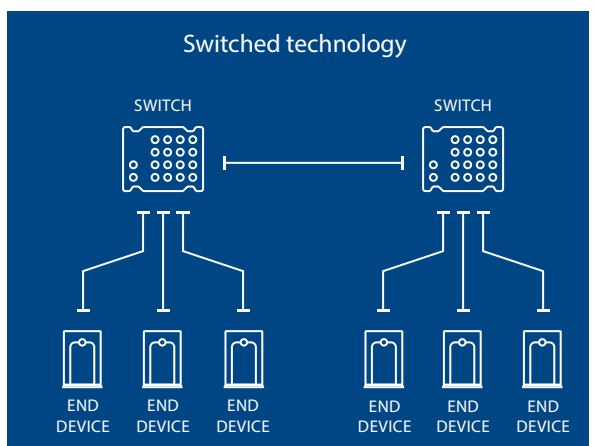
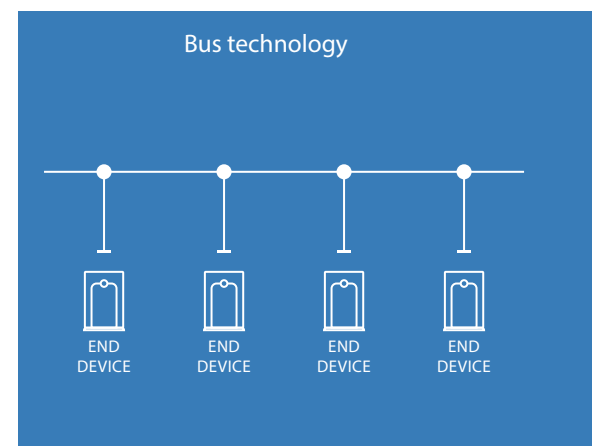

It goes per-se that no converter is needed, if only one class and one bus protocol is implemented in a specific network. The trend towards Ethernet-based network on one side and, on the other side, already existing applications and subsystems lead more

and more to complex structures with multiple bus protocols or situations, where bus technology is combined with Ethernet networks. In all these situations efficient, stable and secure converters are needed.

Our Portfolio of Converters

Any combination of consist network technologies, bus and switched, may be used in a consist. The Selectron Communication Converters family is de-

signed to enable communication between different technology devices in a typical vehicle setting.

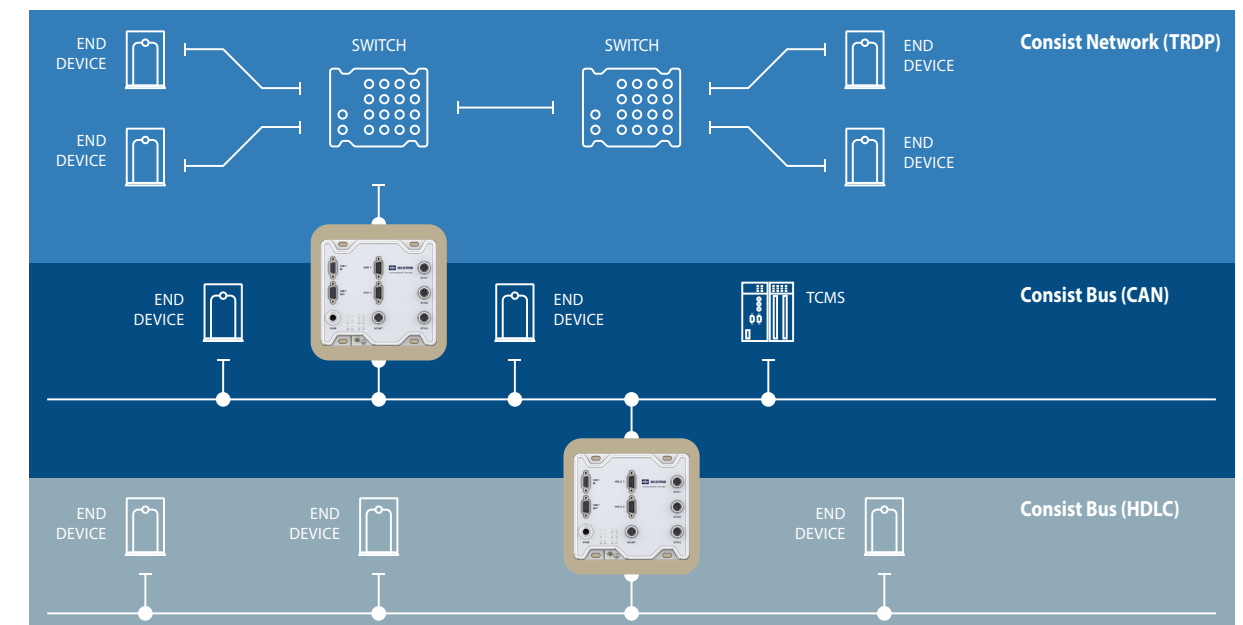

Thanks to the variety of product versions, Selectron Communication Converters are suitable for both retrofits and new fleets. For example, the converters allow the integration of new devices in a legacy technology consist network or they allow legacy devices to communicate over modern networks.

The device acts as a tunnel device to provide the optimal conversion scheme for the connected communication devices: it converts data from any available source, be it a bus technology (MVB, CAN, RS-485, RS-422 or HDLC) or switched technology (Ethernet Consist Network).



The Selectron Communication Converter family is designed to operate in harsh environmental conditions typical of rail vehicles. The devices are fully EN 50155-compliant and offer the highest level of reliability and robustness required by the railway industry. It also offers a network and cable CLI interface for device management (L2, L3 SSH and Telnet, Console), and triple fallback firmware images and bootloader auto-fallback for maximum reliability. Moreover, all the converters are equipped with a wide-range railway power supply that allows any type of installation from 24 V DC to 110 V DC nominal input voltage. Of course, the entire Selectron Communication Converter family is cyber security certified based on SL2.

Selectron Systems AG

Bernstrasse 70
3250 Lyss
Switzerland
Tel: +41 32 387 61 61
Fax: +41 32 397 61 00
www.selectron.ch



 **KNORR-BREMSE**

 **NEW YORK AIR BRAKE**

 **IFE**

 **MERAK**

 **MICROELETTRICA**

 **SELECTRON**

 **KIEPE ELECTRIC**

 **EVAC**

 **ZELISKO**

 **RAILSERVICES**
