

WHAT CONTROLS TIMING, MONITORS VOLTAGE AND SWITCHES LOADS EFFICIENTLY?

ELECTRONIC RELAYS SELECTRON®

Timer Relays

- Pluggable
- Mounting position
- Industrial design

Monitoring relays

- Pluggable
- Mounting position
- Industrial design

Solid-state relays

- 1- and 3-phases



SELECTRON

Our partners / Order information

1

Timer relays

Multifunction timer relays pluggable

2

Multifunction timer relays mounting position

3

Multifunction timer relays industrial design

4

Monitoring relays

Monitoring relays pluggable

5

Monitoring relays industrial design

6

Monitoring relays mounting position

7

Solid-state relays

1- and 3-phases solid state relays

8

Empty-casings

9

10

11

12

Partner / Alphabetical type listing

Content

Our partners in Switzerland.....	2
Our partners in Europe.....	4
Relay-types in alphabetical order – Order-numbers Distributors.....	5

Edition 04.13

Subject to technical changes and amendments to
technical specifications at any time

Our partners in Switzerland

To guarantee optimum availability and short delivery times, orders are placed with our partners directly and are handled exclusively by them.

You find the corresponding order-information on the following pages.



A. SAESSELI & CO. AG
www.elektrogrosshandel.ch

A. Saesseli & Co. AG **Winterthur**

Tel: +41 52 235 26 26
Fax: +41 52 235 26 36
www.saesseli.ch
info@saesseli.ch



dineo SA **Le Mont-sur-Lausanne**

Tel: +41 21 651 25 50
Fax: +41 21 651 25 60
www.dinoe.ch
info@dineo.ch



DISTRELEC

Distrelec AG **Nänikon**

Tel: +41 44 944 99 44
Fax: +41 44 944 99 88
www.distrelec.ch
info@distrelec.ch



Dysbox SA **Sion**

Tel: +41 27 451 80 00
Fax: +41 27 451 80 01
www.dysbox04.ch
info@dysbox04.ch



ElectroLAN SA www.electrolan.ch

Neuenburg
Tel: +41 32 737 88 88
Fax: +41 32 737 88 80
vente@electrolan.ch

Renens
Tel: +41 21 637 01 88
Fax: +41 21 637 01 80
vente@electrolan.ch



Electroplast AG www.electroplast.ch

Horgen
Tel: +41 44 726 04 00
Fax: +41 44 726 04 01
info@electroplast.ch

Electroplast SA
Les Acacias
Tel: +41 22 342 01 60
Fax: +41 22 342 02 11
info@electroplast.ch

Meyrin
Tel: +41 22 782 55 56
Fax: +41 22 782 07 20
info@electroplast.ch



Fabbri SA www.fabbri.ch

Pregassona
Tel: +41 91 973 22 55
Fax: +41 91 973 22 66
info@fabbri.ch

Giubiasco
Tel: +41 91 850 05 35
Fax: +41 91 850 05 36
info@fabbri.ch



Elektro-Material AG www.elektro-material.ch

Zürich
Tel: +41 44 278 12 12
Fax: +41 44 278 12 99
em-zh@elektro-material.ch

Basel
Tel: +41 61 286 13 13
Fax: +41 61 281 49 29
em-ba@elektro-material.ch

Bern
Tel: +41 31 985 85 85
Fax: +41 31 985 83 83
em-be@elektro-material.ch

Luzern
Tel: +41 41 368 08 88
Fax: +41 41 368 08 70
em-lz@elektro-material.ch

Heiden
Tel: +41 71 898 01 01
Fax: +41 71 898 01 02
em-he@elektro-material.ch

Electro-Matériel SA www.electro-materiel.ch

Genf
Tel: +41 22 309 13 13
Fax: +41 22 309 13 33
em-ge@electro-materiel.ch

Renens-Lausanne
Tel: +41 21 637 11 22
Fax: +41 21 637 11 83
em-la@electro-materiel.ch

Sitten
Tel: +41 27 324 40 50
Fax: +41 27 324 40 41
em-si@electro-materiel.ch

Oberwallis/Haut-Valais
Tel: +41 27 324 40 60
Fax: +41 27 324 40 41
em-si@electro-materiel.ch

Our partners in Switzerland

Continuation



Elettro-Materiale SA
www.elettro-materiale.ch

Lamone-Lugano
Tel: +41 91 612 20 20
Fax: +41 91 612 20 30
em-lu@elettro-materiale.ch



Otto Fischer AG
www.ottofischer.ch

Zürich
Tel: +41 44 276 76 76
Fax: +41 44 276 76 86
admin@ofag.ch

Montagny-près-Yverdon
Tel: +41 24 447 47 70
Fax: +41 24 447 47 77
admin@ofag.ch

Camorino
Tel: +41 91 851 30 70
Fax: +41 91 851 30 77
admin@ofag.ch



Winterhalter + Fenner AG
www.w-f.ch

Littau
Tel. +41 41 259 40 50
Fax +41 41 259 40 60
verkauf_li@w-f.ch

St. Gallen
Tel. +41 71 314 77 77
Fax +41 71 314 77 88
verkauf_sg@w-f.ch

Wallisellen
Tel. +41 44 839 57 11
Fax +41 44 839 57 57
verkauf_wa@w-f.ch

Standard AG Industrietechnik



Standard AG
Birsfelden
Tel: +41 61 378 82 00
Fax: +41 61 378 82 01
www.standard.ch
verkauf@standard.ch

Our partners in Europe

Austria

Reliste Steuerungstechnik GmbH

Enzersdorfer Strasse 8-10
2345 Brunn am Gebirge
AUSTRIA
Tel. +43 2236 31 5 25-0
Fax +43 2236 31 5 25-60
office@reliste.via.at

Denmark

H. Jessen Jürgensen A/S

Tempovej 18-22
2750 Ballerup
DENMARK
Tel. +45 70 27 0607
Fax +45 70 26 3405
info@hjj.dk
www.hjj.dk

Finland

SKS Automaatio OY

Martinkyläntie 50
P.O. Box 122
01721 Vantaa
FINLAND
Tel. +358 0 20 764 61
Fax +358 0 20 764 6820
automaatio@sk.fi
www.sk.fi

France

ROSIER SA

13, rue Sigmund Freud
69518 Vaulx en Velin Cédex
FRANCE
Tel. +33 4 72 04 68 61
Fax +33 4 72 04 37 38
contact@rosier.fr

Germany

PromTeg Deutschland GmbH

Florastrasse 8
46459 Rees
GERMANY
Tel. +49 3222 10 98 912
info@promtegdeutschland.de
www.promtegdeutschland.de

Distrelec Schuricht GmbH

Tel: +49 180 522 34 35
Fax: +49 180 522 34 36
scc@distrelec.de
www.distrelec.de

Great Britain

CENTIFLEX SYSTEMS LTD

29 Doune Way
Harleston Norfolk
IP209QB UK
Tel. +44 5602 39 31 64
Fax +44 1473 88 34 30
info@centiflex.com
www.centiflex.com

Netherlands

HESCON INDUSTRIES BV

Rondweg Zuid 17
7102 JD Winterswijk
NETHERLANDS
Tel. +31-(0)88-657 1450
Fax +31-(0)88-657 1451
info@hescon.nl
www.hescon.nl

Norway

DDtC Trading as

Stallbakken 9C
2005 Raelingen
NORWAY
Tel. +47 920 77 000
post@dtc-trading.no
www.dtc.no

Poland

B&L International Ltd.

Raclawicka 46/131
02-601 Warszawa
POLAND
Tel. +48 22 646 46 88
Fax +48 22 646 38 48
info@bil.com.pl

Relay-types in alphabetical order – Order-numbers Distributors

Type	Article no. Selectron	Article no. Distrelec-Schuricht	No. ELFA	No. E	No. VSAS	No. EAN	Page Catalog
CKT K1	42310310	41 08 63	3746087	505 390 100	059.053.060.022	7640119436241	8.40
CKT S1	42310311	41 08 64	3746088	505 390 101	059.053.060.023	7640119436258	8.40
DB 2	41920013	41 06 44	3745100	505 397 100	046.053.060.007	7640119430430	8.42
EMR DF22Q	41230040	22 32 09	1037214	543 300 090	049.053.031.018	7640119436609	6.26
EMR DI22F	41230005	24 19 00	3754712	543 320 000	049.053.031.005	7640119433257	6.2
EMR DP22H	41230008	24 19 06	3754782	543 311 200	049.053.031.007	7640119433288	6.22
EMR DT22G	41230006	24 19 05	3754768	543 380 000	049.053.031.006	7640119433264	6.18
EMR DU21B1	41230000	22 32 08	1037213	543 310 230	049.053.031.015	7640119436593	6.14
EMR DU21C1	41230003	24 19 04	3754736	543 310 900	049.053.031.003	7640119430836	6.14
EMR DU21D	41230001	24 19 02	3754734	543 311 000	049.053.031.001	7640119430829	6.10
EMR DU21D1	41230002	24 19 03	3754735	543 310 800	049.053.031.002	7640119433233	6.14
EMR DU22E	41230004	24 19 01	3754733	543 311 100	049.053.031.004	7640119433240	6.6
EMR II11Q	41230033	22 19 24	3754725	543 320 100	049.053.031.010	7640119434711	7.2
EMR IT13G	41230035	22 19 26	3754767	543 380 022	049.053.031.012	7640119434735	7.18
EMR IU11D	41230032	22 19 23	3623005	543 310 290	049.053.031.009	7640119434704	7.14
EMR IU11D1	41230030	22 19 21	3754746	543 310 090	049.053.031.003	7640119434681	7.10
EMR IU21D1	41230031	22 19 22	3623004	543 310 190	049.053.031.008	7640119434698	7.10
EMR IU11N	41230034	22 19 25	3754747	543 310 072	049.053.031.011	7640119434728	7.6
EMR SU21I	41230009	22 19 10	3754741	543 312 011	049.053.020.001	7640119434063	5.6
EMR SU21J	41230010	22 19 11	3754742	543 312 021	049.053.020.002	7640119434070	5.6
EMR SU21K	41230011	22 19 12	3754743	543 312 031	049.053.020.003	7640119434087	5.6
EMR SU21L	41230012	22 19 13	3754744	543 312 041	049.053.020.004	7640119434094	5.6
EMR SU21M	41230013	22 19 14	3754745	543 312 030	049.053.020.005	7640119434100	5.10
EMR SU21N	41230014	22 19 15	3623000	543 312 000	049.053.020.006	7640119434117	5.10
EMR SI23O	41230015	22 19 16	3754723	543 324 010	049.053.020.007	7640119434124	5.2
EMR SI23P	41230016	22 19 17	3754724	543 324 020	049.053.020.008	7640119434131	5.2
EMR SU31C1	41230017	22 19 18	3623001	543 313 080	049.053.020.009	7640119434148	5.18
EMR SU31D1	41230018	22 19 19	3623002	543 313 090	049.053.020.010	7640119434155	5.18
EMR SU31D	41230019	22 19 20	3623003	543 313 190	049.053.020.011	7640119434162	5.14
EXPOT 1	41920034	42 00 65	3754334	528 391 192	047.053.060.006	7640119430577	2.34

Relay-types in alphabetical order – Order-numbers Distributors

Type	Article no. Selectron	Article no. Distrelec-Schuricht	No. ELFA	No. E	No. VSAS	No. EAN	Page Catalog
HD D0340I	42310270	10 00 09	1041116	543 320 021	059.053.018.015	7640119436616	8.26
HD D2825	42310250	41 08 40	3746064	505 314 451	059.053.018.007	7640119435954	8.18
HD D2825K	42310260	41 08 36	3746060	505 313 751	059.053.018.011	7640119436302	8.23
HD D6035	42310251	41 08 41	3746065	505 314 551	059.053.018.008	7640119435961	8.18
HD D6035K	42310261	41 08 37	3746061	505 313 851	059.053.018.012	7640119436319	8.23
HD D6050	42310252	41 08 42	3746066	505 314 651	059.053.018.009	7640119435978	8.18
HD D6050K	42310262	41 08 38	3746062	505 313 951	059.053.018.013	7640119436326	8.23
HD D6075	42310253	41 08 43	3746067	505 314 751	059.053.018.010	7640119435985	8.20
HD D6075K	42310263	41 08 39	3746063	505 314 351	059.053.018.014	7640119436333	8.24
HK 0,3 LB230	42310305	41 08 68	3746092	505 390 003	059.053.060.019	7640119436029	8.41
HK 0,9	42310302	41 08 67	3746091	505 390 009	059.053.060.017	7640119436005	8.39
HK 2,2	42310304	41 08 65	3746089	505 390 022	059.053.060.016	7640119436012	8.39
HK 3,0	42310300	41 08 66	3746090	505 390 130	059.053.060.015	7640119435992	8.38
HKT 3,0	42310306	41 08 61	3746085	505 390 030	059.053.060.020	7640119436227	8.40
HKT 4,0	42310307	41 08 62	3746086	505 390 140	059.053.060.021	7640119436234	8.40
HL D5208R	42310141	41 08 44	3746068	505 314 851	059.053.023.007	7640119435794	8.37
HL A5250	42310142	41 08 45	3746069	505 314 951	059.053.023.005	7640119435800	8.33
HL D5250	42310143	41 08 46	3746070	505 315 451	059.053.023.004	7640119435817	8.33
HL D5222K	42310144	41 08 47	3746071	505 315 651	059.053.023.006	7640119435824	8.35
HM D0603D	42310080	41 08 50	3746074	505 310 551	059.053.014.011	7640119435732	8.6
HM D0603D PG	42310087	41 08 57	3746081	505 311 751	059.053.014.017	7640119436173	8.6
HM D2704	42310081	41 08 51	3746075	505 310 651	059.053.014.010	7640119435749	8.6
HM D2704 PG	42310086	41 08 56	3746080	505 310 951	059.053.014.016	7640119436166	8.6
HM D6004 PG	42310088	41 08 58	3746082	505 311 851	059.053.014.018	7640119436180	8.6
HQ D6010H	42310085	41 08 55	3746079	505 310 851	059.053.014.015	7640119435787	8.10
HQ D6010H PG	42310092	41 08 60	3746084	505 311 951	059.053.014.020	7640119436210	8.10
HQ D6010L	42310084	41 08 54	3746078	505 310 231	059.053.014.014	7640119435770	8.10
HQ 6010L PG	42310091	41 08 59	3746083	505 310 031	059.053.014.019	7640119436203	8.10
HRK 0,7	41920003	41 06 38	3745092	505 391 200	046.053.060.001	7640119430379	8.32
HS A2825	42310200	41 08 26	3746050	505 315 202	059.053.011.007	7640119435855	8.38

Relay-types in alphabetical order – Order-numbers Distributors

Type	Article no. Selectron	Article no. Distrelec-Schuricht	No. ELFA	No. E	No. VSAS	No. EAN	Page Catalog
HS A5150	42310201	41 08 27	3746051	505 315 302	059.053.012.008	7640119435862	8.14
HS A5175	42310202	41 08 28	3746052	505 315 402	059.053.012.010	7640119435879	8.15
HS D1120D	42310180	41 08 48	3746072	505 315 751	059.053.016.011	7640119435831	8.16
HS D1140D	42310181	41 08 49	3746073	505 315 851	059.053.016.012	7640119435848	8.16
HS D2825	42310203	41 08 29	3746053	505 312 651	059.053.011.006	7640119435886	8.12
HS D2850	42310206	41 08 32	3746056	505 312 951	059.053.011.008	7640119435916	8.14
HS D51125	42310209	41 08 35	3746059	505 313 651	059.053.012.011	7640119435947	8.15
HS D5135M	42310205	41 08 31	3746055	505 312 851	059.053.016.010	7640119435909	8.16
HS D6035	42310204	41 08 30	3746054	505 312 751	059.053.012.006	7640119435893	8.12
HS D6050	42310207	41 08 33	3746057	505 313 451	059.053.012.007	7640119435923	8.14
HS D6075	42310208	41 08 34	3746058	505 313 551	059.053.012.009	7640119435930	8.15
HT D6005H	42310083	41 08 53	3746077	505 310 751	059.053.014.013	7640119435763	8.8
HT D6005L	42310082	41 08 52	3746076	505 310 131	059.053.014.012	7640119435756	8.8
LG 121	41930032	30 02 40	5069970	543 399 190	016.053.061.001	7640119430607	9.2
LG 220	41930006	30 02 41	5069971	543 399 290	016.053.061.003	7640119430584	9.2
MFT DS22A	41230007	24 19 07	3754260	528 380 000	047.053.030.001	7640119433271	4.2
MFT IQ13S	41130001	42 03 92	3754273	528 337 092	047.053.011.024	7640119434261	3.2
MFT IU14S	41130003	42 03 93	3754274	528 337 192	047.053.011.021	7640119434278	3.6
MFT IU24S	41130004	42 03 94	3754275	528 337 292	047.053.011.020	7640119434285	3.6
MFT IT14S	41130007	42 03 95	3754276	528 337 492	047.053.011.023	7640119434308	3.10
MFT ITU24S	41130005	42 03 96	3754277	528 337 392	047.053.011.022	7640119434292	3.14
MFT SA23S	41140008	42 00 52	3754244	528 310 092	047.053.027.010	7640119430140	2.26
MFT SS22S	41140009	42 00 51	3754243	528 380 092	047.053.027.011	7640119430157	2.30
MFT ST22S	41140006	42 00 50	3754242	528 332 092	047.053.027.008	7640119430126	2.18
MFT SU22P	41140012	42 00 49	3754241	528 330 592	047.053.027.007	7640119430188	2.2
MFT SU22S	41140010	42 00 48	3754240	528 330 292	047.053.027.003	7640119430164	2.2
MFT ST51SE	41140007	42 00 60	3754329	528 332 192	047.053.027.009	7640119430133	2.22
MFT SU31S	41140003	42 00 56	3754323	528 330 392	047.053.027.004	7640119430096	2.6
MFT SU41SE	41140004	42 00 57	3754324	528 330 492	047.053.027.005	7640119430102	2.12
MP 1	41230101	24 19 08	4808206	543 397 190	049.053.035.001	7640119430331	6.30

Relay-types in alphabetical order – Order-numbers Distributors

Type	Article no. Selectron	Article no. Distrelec-Schuricht	No. ELFA	No. E	No. VSAS	No. EAN	Page Catalog
SA 1	41230102	24 19 09	4808207	543 397 290	049.053.035.002	7640119430348	6.30
SP 11/101	41930034	30 02 40	5069970	543 398 190	016.053.061.002	7640119430614	9.2
SP 11/201	41930010	30 02 41	5069971	543 398 290	016.053.061.004	7640119430591	9.2
SSK 11 N	41910006	42 50 11	4808205	528 390 092	049.053.060.002	7640119430355	2.34 / 5.22
TS 90 M6	42310320	41 08 69	3746093	505 390 200	059.053.060.018	7640119436357	8.39

Chapter Title

Content

Multifunction timer relay pluggable

Multifunctional time delay relay	
MFT SU22S, MFT SU22P	2
Technical data.....	3
Function descriptions.....	4
Connection	5
Multifunctional time delay relay, optional with instantaneous contact	
MFT SU31S.....	6
Technical data.....	7
Function descriptions.....	8
Connection	11
Multifunctional time delay relay with external potentiometer	
MFT SU41SE	12
Technical data.....	13
Function descriptions.....	14
Connection	15
Multifunctional clock-pulse generator relay	
Technical data.....	19
Function descriptions.....	20
Connection	21
Multifunctional clock-pulse generator relay with external potentiometer	
MFT ST51SE	22
Technical data.....	23
Function descriptions.....	24
Connection	25
Delay off without supply voltage	
MFT SA23S	26
Technical data.....	27
Function descriptions	28
Connection	29
Star-delta relay	
MFT SS22S.....	30
Technical data.....	31
Function descriptions.....	32
Connection	32
Accessories time delay relays.....	34
Plug in socket	34
External potentiometer.....	34
Technical safety advice	35
Prescriptions and standards.....	36

Edition 06.16

Subject to technical changes and amendments to technical specifications at any time

Multifunctional time delay relay

MFT SU22S, MFT SU22P



MFT SU22S

- **7 Functions, 7 time ranges**
- **Multivoltage:**
12 ... 240 VAC/DC
- **2 output contacts**

Functions

- E** Delay on
- E** Delay on - version with control contact as opening contact
- A** Delay off
- I2** Pulse extension with control contact
- W2** Wiping on trailing edge
- E1** Delay on with control contact
- I1** Pulse limitation timer voltage control
- B2** Cycling timer starting on a pause

Time end ranges

Adjustment range 0,05 s ... 100 h

Output relay

2 potential free change over contacts
250 VAC 8 A

Indicators

- Green LED ON: indication of supply voltage
- Green LED flashes: indication of time
- Yellow LED ON/OFF: indication of relay output

Connecting voltage

12 ... 240 VA/DC -10% +10%
48 ... 63 Hz, 100% duration of operation, IEC class 1c

Reference data

Selectron® MFT	Article no.
MFT SU22S	41140010
MFT SU22P	41140012
(Order data see chapter 1)	

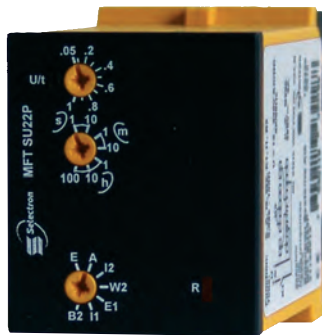

MFT SU22P

Multifunctional time delay relay

MFT SU22S, MFT SU22P

Technical data	MFT SU22S	MFT SU22P
Nominal consumption		
	12 ... 240 VAC/DC	6 VA / 2 W
Control contact / Voltage controlled		
Parallel switching of loads possible	yes	no
Parallel minimum load	1 VA or 0.5 W	–
Voltage dependence:	The potential between connections 2 and 5 must cover 90% of the supply voltage	Potential free control contact between connections 6 and 7 The internal voltage on these connectors is on the same potential as supply voltage
Connecting length between connections 2 and 5:	10 m or capacity <10 nF	–
Connecting length between connections 6 and 7:	At 230 VAC 10 VDC <1 mA	10 m or capacity <10 nF
Resistance	>1 MΩ (contact K2 open)	–
Rest current at parallel load:	approx. 2 mA at contact K2 open	–
Accuracy		
Base accuracy		±1% of scale limit
Repetition accuracy		<5 ms or <0.5%
Adjustment accuracy		≤5% of scale limit
Temperature influence		≤0.01% / °C
Voltage influence		–
Reaction times		
Operating return time K1		max. 60 ms / 30 ms
Reaction time K2		max. 30 ms
Min. pulse/pause time K2		AC 100 ms / DC 50 ms
Recovery time		max. 100 ms

Type key

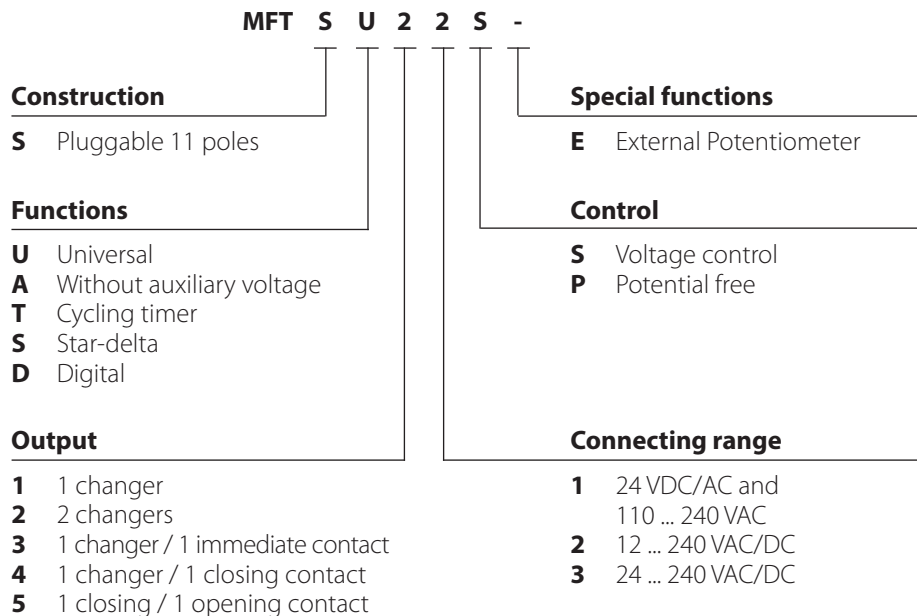

Multifunctional time delay relay

MFT SU22S, MFT SU22P

Function descriptions

E - Delay on

When the supply voltage U (K1 closed) is applied, the set interval t begins (green LED U/t flashes). After the interval t has expired

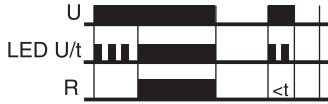

(green LED U/t illuminated) the output relay switches into on-position (yellow LED illuminated). This status remains until the supply voltage U (K1 opened) is interrupted. If the supply voltage U is interrupted before expiry of the interval t, the interval already expired is erased and is restarted when the supply voltage U (K1 closed) is next applied.

E - Delay on - version with control contact as opening contact

The supply voltage U must be constantly applied to the device (green LED U/t illuminated). When the control contact K2 is

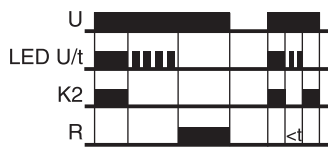

opened, the set interval t begins (green LED U/t flashes). After the interval t has expired the output relay switches into on-position (yellow LED illuminated). If the control contact K2 is closed before the interval t has expired, the interval already expired is erased and is restarted with the next cycle.

A - Delay off

The supply voltage U (K1 closed or permanently connected) must be constantly applied to the device (green LED U/t illuminated).

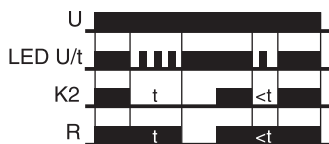

When the control contact K2 is closed, the output relay R switches into on-position (yellow LED illuminated). If the control contact K2 is opened, the set interval t begins (green LED U/t flashes). After the interval t has expired (green LED U/t illuminated) the output relay switches into off-position (yellow LED not illuminated). If the control contact K2 is closed again before the interval t (green LED U/t illuminated) has expired, the interval already expired is erased and is restarted with the next cycle.

I2 - Pulse extension with control contact

The supply voltage U (K1 closed or permanently connected) must be constantly applied to the device (green LED U/t illuminated).

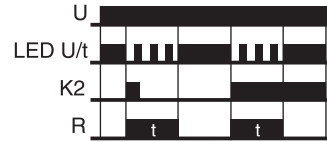

When the control contact K2 is closed, the output relay R switches into on-position (yellow LED illuminated) and the set interval t begins (green LED U/t flashes). After the interval t has expired (green LED U/t illuminated) the output relay switches into off-position (yellow LED not illuminated). During the interval, the control contact K2 can be operated any number of times. A further cycle can only be started when the cycle run has been completed.

W2 - Wiping on trailing edge

The supply voltage U (K1 closed or permanently connected) must be constantly applied to the device (green LED U/t illuminated).

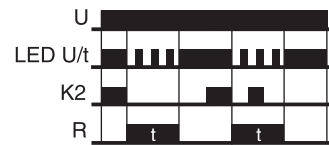

Closing the control contact K2 has no influence on the condition of the output relay R. When the control contact K2 is opened, the output relay switches into on-position (yellow LED illuminated) and the set interval t begins (green LED U/t flashes). After the interval t has expired (green LED U/t illuminated), the output relay switches into off-position (yellow LED not illuminated). During the interval, the control contact K2 can be operated any number of times. A further cycle can only be started when a cycle run has been completed.

E1 - Delay on with control contact

The supply voltage U (K1 closed or permanently connected) must be constantly applied to the device (green LED U/t illuminated). When

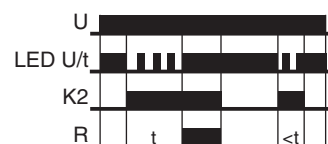

the control contact K2 is closed, the set interval t begins (green U/tLED flashes). After the interval t has expired (green LED U/t illuminated) the output relay R switches into on-position (yellow LED illuminated). This status remains until the control contact K2 is opened. If the control contact K2 is opened before the interval t has expired, the interval already expired is erased and is restarted with the next cycle.

Multifunctional time delay relay

MFT SU22S, MFT SU22P

Function descriptions

I1 - Pulse limitation timer voltage control

When supply voltage U (K1 closed) is applied, the output relay R switches into on-position (yellow LED illuminated) and the set

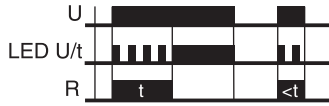

interval t begins (green LED U/t flashes). After the interval t has expired (green LED U/t illuminated) the output relay switches into off-position (yellow LED not illuminated). This status remains until the supply voltage (K1 opened) is interrupted. If the supply voltage is interrupted before the interval t has expired, the output relay switches into off-position. The interval t already expired is erased and is restarted when the supply voltage is next applied.

B2 - Cycling timer starting on a pause

When the supply voltage U is applied, the set interval t begins (green LED U/t flashes). After the interval t has expired, the output

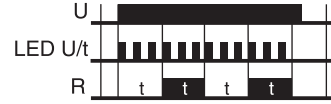

relay R switches into on-position (yellow LED illuminated) and the set interval t begins again. After the interval t has expired, the output relay switches into off-position (yellow LED not illuminated). The output relay is triggered in the ratio 1:1 until the supply voltage is interrupted.

Connection

MFT SU22S

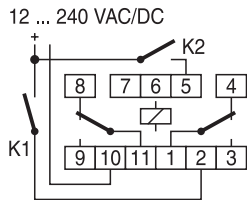

MFT SU22P

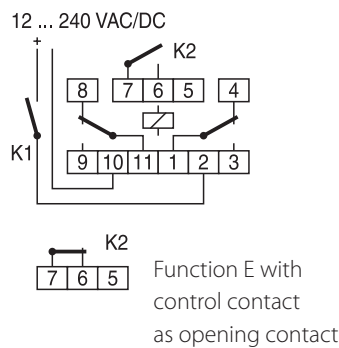

Load limit curves

MFT SU22S, MFT SU22P

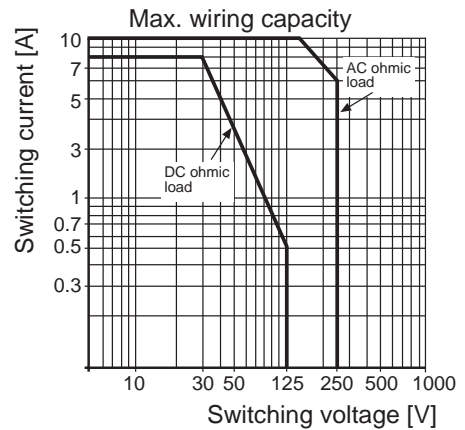

Dimensions

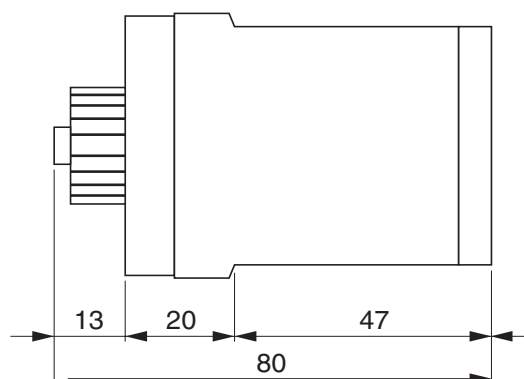
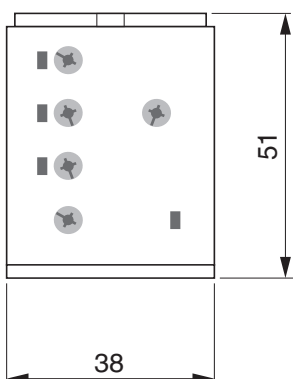

Multifunctional time delay relay, optional with instantaneous contact

MFT SU31S

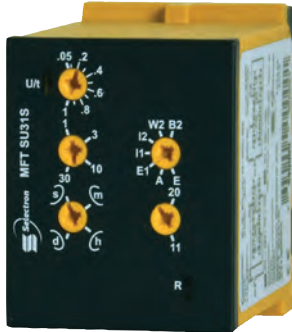

MFT SU31S

- **14 Functions, 16 time ranges**
- **Multivoltage:**
24 VAC/DC and 110 ... 240 VAC
- **2 output contacts**

Functions, optional with instantaneous contact

- E** Delay on
- A** Delay off
- E1** Delay on with control contact
- I1** Pulse limitation timer voltage control
- I2** Pulse extension with control contact
- W2** Wiping on trailing edge with control contact
- B2** Cycling timer starting on a pause
- 11** Immediate contact and delayed contact
- 20** Both contacts are delayed contacts

Time end ranges

Adjustment range 0,05 s ... 30 days (

Output relay

2 changes

250 Vac 5 A units close together, 8 A units not close together

Indicators

Green LED ON: indication of supply voltage

Green LED flashes: indication of time

Yellow LED ON/OFF: indication of relay output

Connecting voltage

24 VDC $\pm 10\%$

24 VAC -15% ... +10%

110 ... 240 VAC -15% ... +10%

Reference data

Selectron® MFT	Article no.
MFT-SU31S	41140003
(Order data see chapter 1)	

Multifunctional time delay relay, optional with instantaneous contact

MFT SU31S

Technical data	
Nominal consumption	
24 VAC/DC	0.8 VA / 0.6 W
110 VAC	2.5 VA / 0.7 W
240 VAC	20 VA / 1.0 W
Control contact / Voltage controlled	
Parallel switching of loads possible	
Parallel minimum load	1 VA or 0.5 W
Voltage dependence:	The potential between connections 2 and 5, resp. 7 and 5, must cover 90% of the supply voltage
Connecting length between connections 10 and 5:	10 m or capacity <10 nF
Resistance	>1 MΩ (contact K2 open)
Rest current at parallel load:	approx. 2 mA at contact K2 open
Control pulse length	DC min. 50 ms AC min. 100 ms
Accuracy	
Base accuracy	±5% of scale limit
Repeatability of the scale limit at constant conditions	±5% or ±100 ms
Adjustment accuracy	<5% of scale limit
Temperature influence	≤0.05% / °C
Reaction times	
Operating return time K1	max. 60 ms / 30 ms
Reaction time K2	max. 30 ms
Min. pulse/pause time K2	AC 50 ms / DC 50 ms
Recovery time	max. 100 ms

Type key

MFT S U 3 1 S -	
Construction	Special functions
S Pluggable 11 poles	E External Potentiometer
Functions	Control
U Universal	S Voltage control
A Without auxiliary voltage	P Potential free
T Cycling timer	
S Star-delta	
D Digital	
Output	Connecting range
1 1 changer	1 24 VDC/AC and 110 ... 240 VAC
2 2 changers	2 12 ... 240 VAC/DC
3 1 changer / 1 immediate contact	3 24 ... 240 VAC/DC
4 1 changer / 1 closing contact	
5 1 closing / 1 opening contact	

Multifunctional time delay relay, optional with instantaneous contact

MFT SU31S

Function descriptions

E-11 - Delay on

When the supply voltage U (K1 closed) is applied, the instantaneous contact switches into on-position and the set

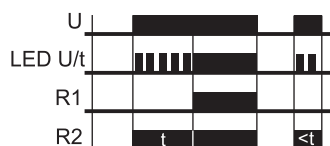

interval t begins (green LED U/t flashes). After the interval t has expired (green LED U/t illuminated) the delayed contact switches into on-position (yellow LED R illuminated).

This status remains until the supply voltage is interrupted. If the supply voltage is interrupted before the expiry of the interval t, the interval already expired is erased and is restarted when the supply voltage is next applied.

A-11 - Delay off

The supply voltage U (K1 closed) must be constantly applied to the device (green LED U/t illuminated). When the control contact K2 is closed, both contacts switch into on-position (yellow LED R illuminated). If the control

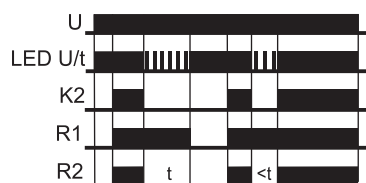

contact is opened, the instantaneous contact switches into off-position and the set interval t begins (green LED U/t flashes). After the interval t has expired (green LED U/t illuminated) the delayed contact switches into off-position (yellow LED R not illuminated). If the control contact is closed again before the interval t has expired, the interval already expired is erased and is restarted with the next cycle.

E1-11 - Delay on with control contact

The supply voltage U (K1 closed) must be constantly applied to the device (green LED U/t illuminated). When the control

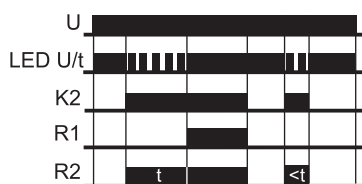

contact K2 is closed, the instantaneous contact switches into on-position and the set interval t begins (green LED U/t flashes). After the interval t has expired (green LED U/t illuminated) the delayed contact switches into on-position (yellow LED R illuminated).

This status remains until the control contact is opened again. If the control contact is opened before the interval t has expired, the interval already expired is erased and is restarted with the next cycle.

I1-11 - Pulse limitation timer voltage control

When the supply voltage U (K1 closed) is applied, both contacts switch into on-position (yellow LED R illuminated)

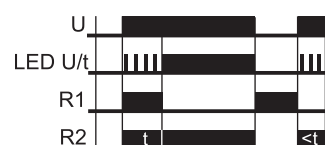

and the set interval t begins (green LED U/t flashes). After the interval t has expired (green LED U/t illuminated) the delayed contact switches into off-position (yellow LED R not illuminated). This status remains until the supply voltage is interrupted.

If the supply voltage is interrupted before the interval t has expired, both contacts switch into off-position. The interval already expired is erased and is restarted when the supply voltage is next applied.

I2-11 - Pulse extension with control contact

The supply voltage U (K1 closed) must be constantly applied to the device (green U/t LED illuminated). When the control

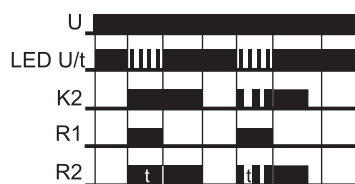

contact K2 is closed, both contacts switch into on-position (yellow LED R illuminated) and the set interval t begins (green LED U/t flashes). After the interval t has expired (green LED U/t illuminated) the delayed contact switches into off-position (yellow LED R not illuminated). The instantaneous contact remains in on-position, until the control contact is opened again. During the interval, the control contact (and the instantaneous contact) can be operated any number of times. A further cycle can only be started when the cycle run has been completed.

Multifunctional time delay relay, optional with instantaneous contact

MFT SU31S

Function descriptions

W2-11 - Wiping on trailing edge with control contact

The supply voltage U (K1 closed) must be constantly applied to the device (green LED U/t illuminated). When the control

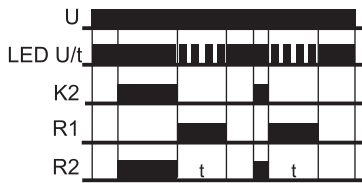

contact K2 is closed the instantaneous contact switches into on-position. When the control contact K2 is opened, the instantaneous contact switches into off-position, the delayed contact switches into on-position (yellow LED R illuminated) and the set interval t begins (green LED U/t flashes). After the interval t has expired (green LED U/t illuminated), the delayed contact switches into off-position (yellow LED R not illuminated). During the interval, the control contact (and the instantaneous contact) can be operated any number of times. A further cycle can only be started when the cycle run has been completed.

B2-11 - Cycling timer starting on a pause

When the supply voltage U (K1 closed) is applied, the instantaneous contact switches into on-position and the set

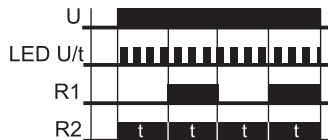

interval t begins (green LED U/t flashes). After the interval t has expired, the delayed contact switches into on-position (yellow LED R illuminated) and the set interval t begins again. After the interval t has expired, the delayed contact switches into off-position (yellow LED R not illuminated). The delayed contact is triggered at a ratio of 1:1 until the supply voltage is interrupted.

E-20 - Delay on

When the supply voltage U (K1 closed) is applied, the set interval t begins (green LED U/t flashes). After the interval t has

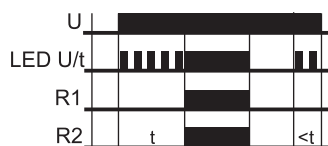

expired (green LED U/t illuminated) the output relays switch into on-position (yellow LED R illuminated).

This status remains until the supply voltage is interrupted. If the supply voltage is interrupted before the expiry of the in-

terval t, the interval already expired is erased and is restarted when the supply voltage is next applied.

A-20 - Delay off

The supply voltage U (K1 closed) must be constantly applied to the device (green LED U/t illuminated). When the control

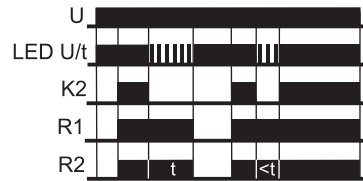

contact K2 is closed, the output relays switch into on-position (yellow LED R illuminated). If the control contact is opened, the set interval t begins (green LED U/t flashes). After the interval t has expired (green LED U/t illuminated) the output relays switch into off-position (yellow LED R not illuminated). If the control contact is closed again before the interval t has expired, the interval already expired is erased and is restarted with the next cycle.

E1-20 - Delay on with control contact

The supply voltage U (K1 closed) must be constantly applied to the device (green LED U/t illuminated). When the control contact K2 is closed, the set interval t

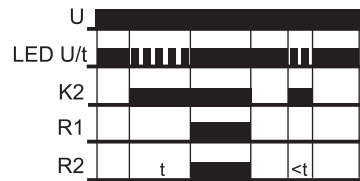

begins (green LED U/t flashes). After the interval t has expired (green LED U/t illuminated) the output relays switch into on-position (yellow LED R illuminated). This status remains until the control contact is opened again. If the control contact is opened before the interval t has expired, the interval already expired is erased and is restarted with the next cycle.

Multifunctional time delay relay, optional with instantaneous contact

MFT SU31S,

Function descriptions

I1-20 - Wiping on leading edge voltage control

When the supply voltage U (K1 closed) is applied, the output relays switch into on-position (yellow LED R illuminated)

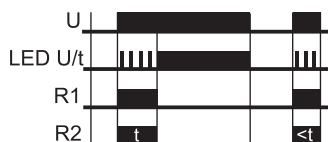

and the set interval t begins (green LED U/t flashes). After the interval t has expired (green LED U/t illuminated) the output relays switch into

off-position (yellow LED R not illuminated).

This status remains until the supply voltage is interrupted. If the supply voltage is interrupted before the interval t has expired, the output relays switch into off-position. The interval already expired is erased and is restarted when the supply voltage is next applied.

I2-20 - Wiping on leading edge with control contact

The supply voltage U (K1 closed) must be constantly applied to the device (green LED U/t illuminated). When the control

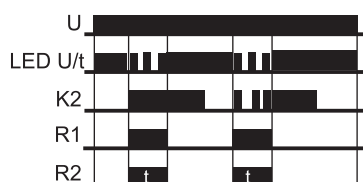

contact K2 is closed, the output relays switch into on-position (yellow LED R illuminated) and the set interval t begins (green LED U/t flashes). After the interval t has expired (green LED U/t illuminated) the output relays switch into off-position (yellow LED R not illuminated). During the interval, the control contact can be operated any number of times. A further cycle can only be started when the cycle run has been completed.

W2-20 - Wiping on a trailing edge with control contact

The supply voltage U (K1 closed) must be constantly applied to the device (green LED U/t illuminated). Closing the con-

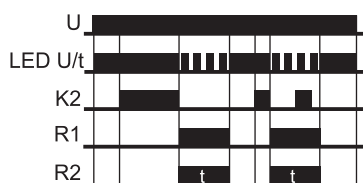

control contact K2 has no influence on the condition of the output relays. When the control contact is opened, the output relays switch into on-position (yellow LED R illuminated) and the set interval t begins (green LED U/t flashes). After the interval t has expired (green LED U/t illuminated), the output

relays switch into off-position (yellow LED R not illuminated). During the interval, the control contact can be operated any number of times. A further cycle can only be started when the cycle run has been completed.

B2-20 - Cycling timer starting on a pause

When the supply voltage U (K1 closed) is applied, the set interval t begins (green LED U/t flashes). After the interval t has

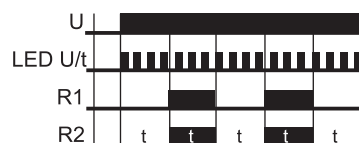

expired, the output relays switch into on-position (yellow LED R illuminated) and the set interval t begins again. After the interval t has expired, the output relays switch into off-position (yellow LED R not illuminated). The output relays are triggered at a ratio of 1:1 until the supply voltage is interrupted.

Multifunctional time delay relay, optional with instantaneous contact

MFT SU31S

Connection

MFT SU31S

110 ... 240 V~

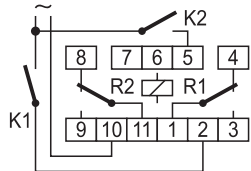

11 R1=□ R2 Instantaneous-contact

20 R1=R2=□

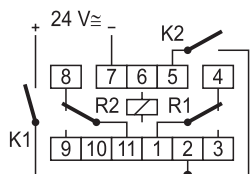

11 R1=□ R2 Instantaneous-contact

20 R1=R2=□

Load limit curves

MFT SU31S

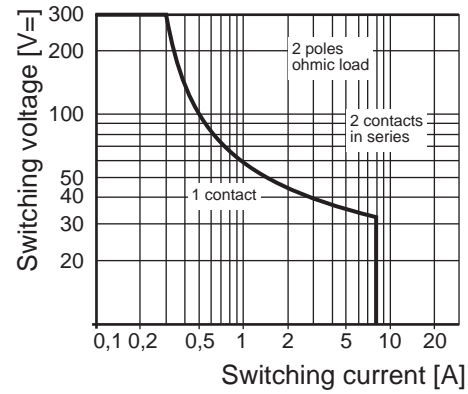

Dimensions

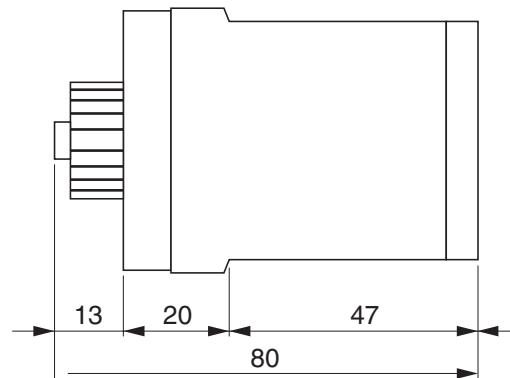
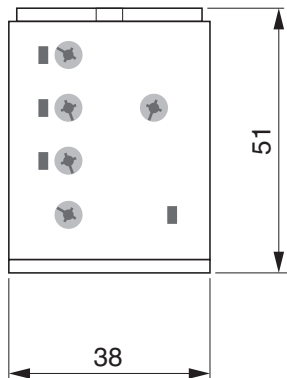

Multifunction time delay relay with external potentiometer

MFT SU41SE

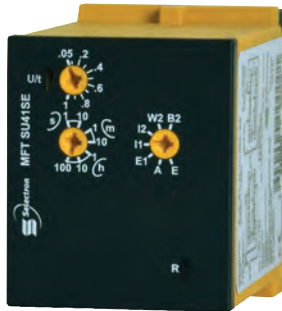

MFT SU41SE

- **7 Functions, 7 time ranges**
- **Multivoltage:**
24 VAC/DC
110 ... 240 VAC
- **2 output contacts**

Functions

- E** Delay on
- A** Delay off without auxiliary voltage
- E1** Delay on with control contact
- I1** Pulse limitation timer voltage control
- I2** Pulse extension with control contact
- W2** Wiping on trailing edge
- B2** Cycling timer starting on a pause

Time end ranges

Adjustment range 0,05 s ... 100 h

Output relay

1 change over and 1 closing contact potential free
250 Vac 5 A units close together, 8 A units not close together

Indicators

Green LED ON: indication of supply voltage
Green LED flashes: indication of time
Yellow LED ON/OFF: indication of relay output

Connecting voltage

24 VDC $\pm 10\%$
24 VAC -15% ... +10%
110 ... 240 VAC -15% ... +10%

Reference data

Selectron® MFT	Article no.
MFT-SU41SE	41140004
(Order data see chapter 1)	

Multifunctional time delay relay with external potentiometer

MFT SU41SE

Technical data	
Nominal consumption	
24 VAC/DC	0.8 VA / 0.6 W
110 VAC	2.4 VA / 0.6 W
240 VAC	19 VA / 1.1 W
Control contact / Voltage controlled	
Parallel switching of loads possible	
Parallel minimum load	1 VA or 0.5 W
Voltage dependence:	The potential between connections 2 and 5, resp. 7 and 5, must cover 90% of the supply voltage
Connecting length between connections 10 and 5:	10 m or capacity <10 nF
Resistance	>1 MΩ (contact K2 open)
Rest current at parallel load:	approx. 2 mA at contact K2 open
External Potentiometer 1 MΩ	Voltage on contact 6 and 8 24 VAC/DC resp. 110 ... 240 VAC Line length max. 5m (twisted pair)
Control pulse length	DC min. 50 ms AC min.100 ms
Accuracy	
Base accuracy	±5% of scale limit
Repeatability of the scale limit at constant conditions	±5% or ±100 ms
Adjustment accuracy	<5% of scale limit
Temperature influence	≤0.05% / °C
Reaction times	
Operating return time K1	max. 60 ms / 30 ms
Reaction time K2	max. 30 ms
Min. pulse/pause time K2	AC 50 ms / DC 50 ms
Recovery time	max. 100 ms

Type key

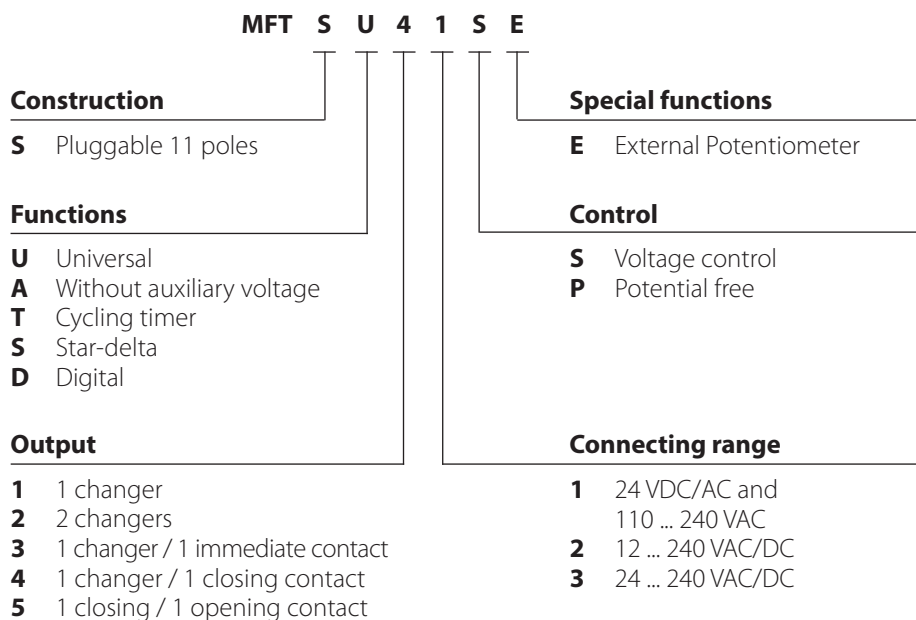

Multifunctional time delay relay with external potentiometer

MFT SU41SE

Function descriptions

E - Delay on

When the supply voltage U (K1 closed) is applied, the set interval t begins (green LED U/t flashes). After the interval t has expired



(green LED U/t illuminated) the output relay switches into on-position (yellow LED illuminated). This status remains until the supply voltage U (K1 opened) is interrupted. If the supply voltage U is interrupted before expiry of the interval t, the interval already expired is erased and is restarted when the supply voltage U (K1 closed) is next applied.

A - Delay off

The supply voltage U (K1 closed or permanently connected) must be constantly applied to the device (green LED U/t illuminated).

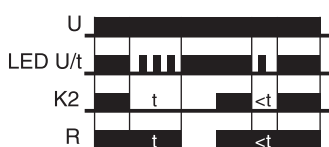

When the control contact K2 is closed, the output relay R switches into on-position (yellow LED illuminated). If the control contact K2 is opened, the set interval t begins (green LED U/t flashes). After the interval t has expired (green LED U/t illuminated) the output relay switches into off-position (yellow LED not illuminated).

If the control contact K2 is closed again before the interval t (green LED U/t illuminated) has expired, the interval already expired is erased and is restarted with the next cycle.

B2 - Cycling timer starting on a pause

When the supply voltage U is applied, the set interval t begins (green LED U/t flashes). After the interval t has expired,



the output relay R switches into on-position (yellow LED illuminated) and the set interval t begins again. After the interval t has expired, the output relay switches into off-position (yellow LED not illuminated). The output relay is triggered in the ratio 1:1 until the supply voltage is interrupted.

I1 - Pulse limitation timer voltage control

When supply voltage U (K1 closed) is applied, the output relay R switches into on-position (yellow LED illuminated) and



the set interval t begins (green LED U/t flashes). After the interval t has expired (green LED U/t illuminated) the output relay switches into off-position (yellow LED not illuminated). This status remains until the supply voltage (K1 opened) is interrupted. If the supply voltage is interrupted before the interval t has expired, the output relay switches into off-position. The interval t already expired is erased and is restarted when the supply voltage is next applied.

I2 - Pulse extension with control contact

The supply voltage U (K1 closed or permanently connected) must be constantly applied to the device (green LED U/t illuminated).

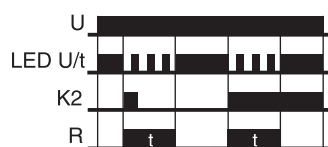

When the control contact K2 is closed, the output relay R switches into on-position (yellow LED illuminated) and the set interval t begins (green LED U/t flashes). After the interval t has expired (green LED U/t illuminated) the output relay switches into off-position (yellow LED not illuminated). During the interval, the control contact K2 can be operated any number of times. A further cycle can only be started when the cycle run has been completed.

W2 - Wiping on trailing edge

The supply voltage U (K1 closed or permanently connected) must be constantly applied to the device (green LED U/t illuminated).

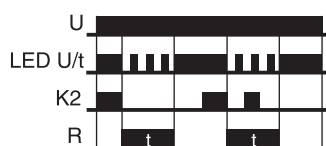

Closing the control contact K2 has no influence on the condition of the output relay R. When the control contact K2 is opened, the output relay switches into on-position (yellow LED illuminated) and the set interval t begins (green LED U/t flashes). After the interval t has expired (green LED U/t illuminated), the output relay switches into off-position (yellow LED not illuminated). During the interval, the control contact K2 can be operated any number of times. A further cycle can only be started when a cycle run has been completed.

Multifunctional time delay relay with external potentiometer

MFT SU41SE

Function descriptions

E1 - Delay on with control contact

The supply voltage U (K1 closed or permanently connected) must be constantly applied to the device (green LED U/t illuminated).

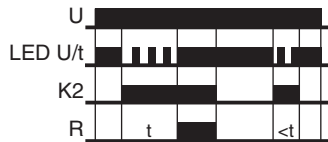

When the control contact K2 is closed, the set interval t begins (green U/tLED flashes). After the interval t has expired (green LED U/t illuminated) the output relay R switches into on-position (yellow LED illuminated). This status remains until the control contact K2 is opened. If the control contact K2 is opened before the interval t has expired, the interval already expired is erased and is restarted with the next cycle.

Connection

MFT SU41SE

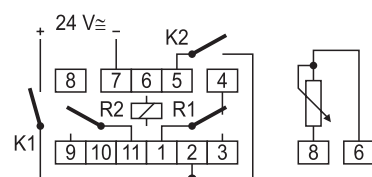
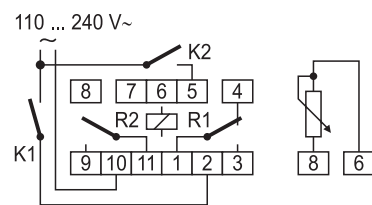

Multifunction time delay relay with external potentiometer

MFT SU41SE

Load limit curves

MFT SU41SE

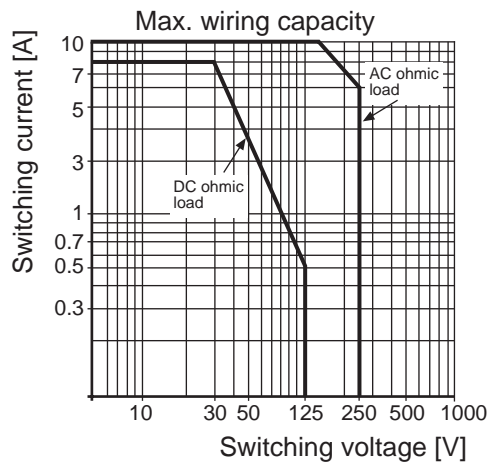

Dimensions

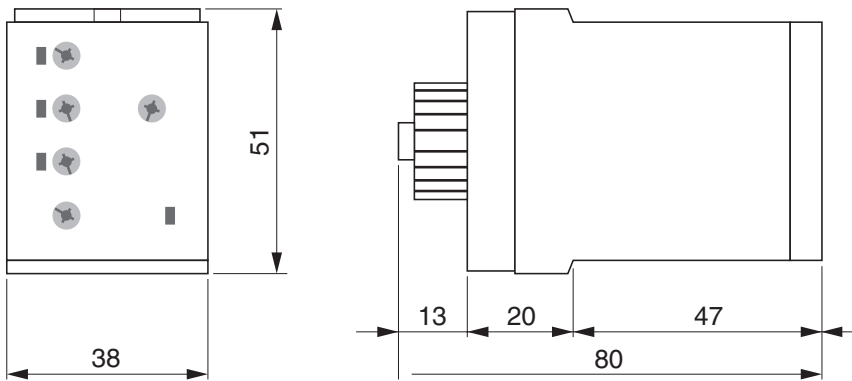

Multifunctional clock-pulse generator relay

MFT ST22S

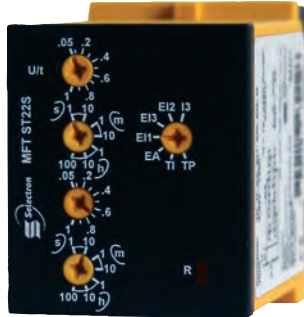

MFT ST22S

- **7 Function, 7 timer ranges**
- **Multivoltage:**
12 ... 240 VAC/DC
- **2 Output contacts**

Functions

- TP** Cycling timer relay beginning on a pause
- TI** Cycling timer relay beginning on a pulse
- EA** Delay on and delay off
- E11** Input delay pulse limitation timer voltage control
- E13** Input delay pulse limitation with control contact
- E12** Wiping on leading and trailing edge with control contact
- I3** Pulse detection

Time end ranges

Adjustable 0,05 s ... 100 h

Output relay

2 potential free change over contact
250 VAC 8 A

Indicators

- Green LED ON: indication of supply voltage
- Green LED flashes slowly: indication of time t1
- Green LED flashes fast: indication of time t2
- Yellow LED ON/OFF: indication of relay output

Connecting voltage

12 ... 240 VAC/DC -10% +10%
48 ... 63 Hz, 100% duration of operation, IEC class 1c

Reference data

Selectron® MFT	Article no.
MFT ST22S	41140006
(Order data see chapter 1)	

Multifunctional clock-pulse generator relay

MFT ST22S

Technical data	
Nominal consumption	
12 ... 240 VAC/DC	6 VA / 2 W
Control contact / Voltage controlled	
Parallel switching of loads possible	
Parallel minimum load	1 VA or 0.5 W
Voltage dependence:	The potential between connections 2 and 5 must cover 90% of the supply voltage.
Connecting length between connections 2 and 5:	10 m or capacity <10 nF
Resistance	>1 MΩ (contact K2 open)
Rest current at parallel load:	approx. 2 mA at contact K2 open
Accuracy	
Base accuracy	±1% of scale limits
Repetition accuracy	±5ms or <0.5%
Adjustment accuracy	<5% of scale limits
Temperature influence	≤0.01% / °C
Voltage influence	–
Reaction times	
Operating/return time K1	max. 60 ms / 30 ms
Reaction time K2	max. 30 ms
Min. pulse/pause time K2	AC 100 ms / DC 50 ms
Recovery time	max. 100 ms

Type key

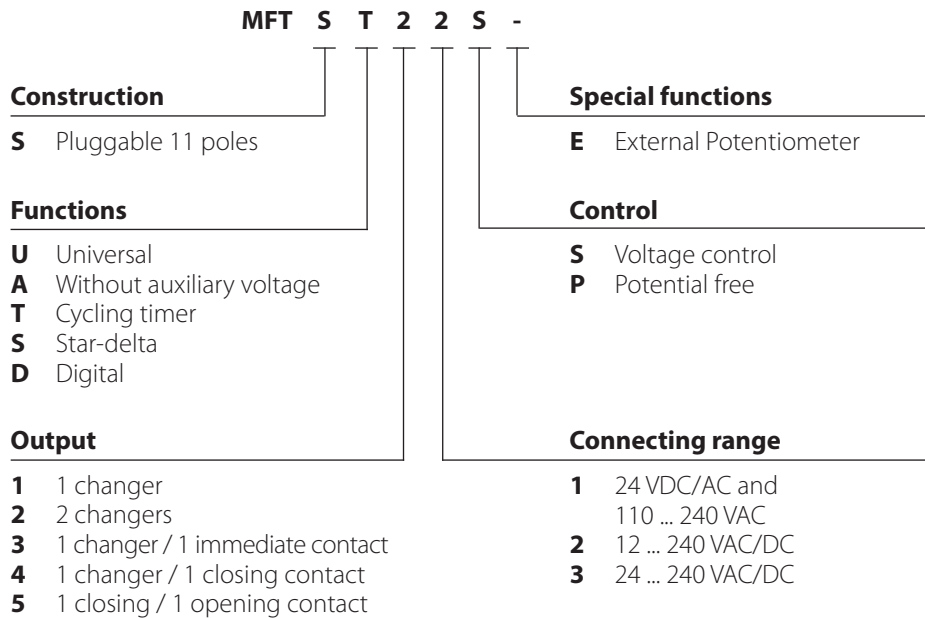

Multifunctional clock-pulse generator relay

MFT ST22S

Function descriptions

TP - Cycling timer relay beginning on a pause

When the supply voltage U (K1 closed) is applied, the set interval t1 begins (green LED U/t flashes slowly). After the interval t1 has

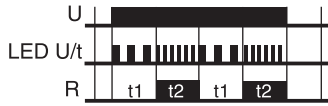

expired, the output relay R switches into on-position (yellow LED illuminated) and the set interval t2 begins (green LED U/t flashes fast). After the interval t2 has expired, the output relay switches into off-position (yellow LED not illuminated).

The output relay is triggered in the ratio of the two set intervals until the supply voltage U (K1 opened) is interrupted.

TI - Cycling timer relay beginning on a pulse

When the supply voltage U (K1 closed) is applied, the output relay R switches into on-position (yellow LED illuminated) and the set

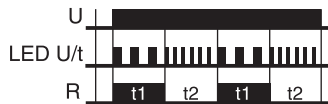

interval t1 begins (green LED U/t flashes slowly). After the interval t1 has expired, the output relay switches into off-position (yellow LED not illuminated) and the set interval t2 begins (green LED U/t flashes fast). After the interval t2 has expired, the output relay switches into on-position again (yellow LED illuminated).

The output relay is triggered in the ratio of the two set intervals until the supply U (K1 opened) voltage is interrupted.

EA -Delay on and delay off

The supply voltage U (K1 closed or permanently connected) must be constantly applied to the device (green LED U/t

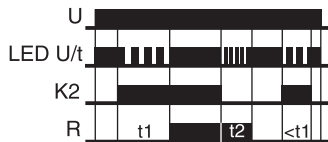

illuminated). When the control contact K2 is closed, the set interval t1 begins (green LED U/t flashes slowly). After the interval t1 has expired, the output relay R switches into on-position (yellow LED illuminated). When the control contact K2 is opened, the set interval t2 begins (green LED U/t flashes fast). After the interval t2 has expired, the output relay switches into off-position (yellow LED not illuminated).

If the control contact K2 is opened before the interval t1 has expired, the interval already expired is erased and is restarted with the next cycle.

EI1 - Input delay pulse limitation timer voltage control

When the supply voltage U (K1 closed) is applied, the set interval t1 begins (green LED U/t flashes slowly). After the interval t1 has



expired, the output relay R switches into on-position (yellow LED illuminated) and the set interval t2 begins (green LED U/t flashes fast). After the interval t2 has expired, the output relay switches into off-position (yellow LED not illuminated). If the supply voltage is interrupted before the interval t1+t2 has expired, the interval already expired is erased and is restarted when the supply voltage is next applied.

EI3 - Input delay pulse limitation timer with control contact

The supply voltage U (K1 closed) must be constantly applied to the device (green LED U/t illuminated). When the control contact K2

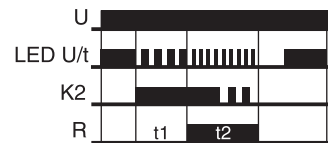

is closed, the set interval t1 begins (green LED U/t flashes slowly). After the interval t1 has expired, the output relay switches into on-position (yellow LED illuminated) and the set interval t2 begins (green LED U/t flashes fast). After the interval t2 has expired, the output relay switches into off-position (yellow LED not illuminated). During the interval, the control contact K2 can be operated any number of times. A further cycle can only be started when the cycle run has been completed.

Multifunctional clock-pulse generator relay

MFT ST22S

Function descriptions

EI2 - Wiping on leading and trailing edge with control contact

The supply voltage U must be constantly applied to the device (green LED U/t illuminated). When the control contact K2 is closed,

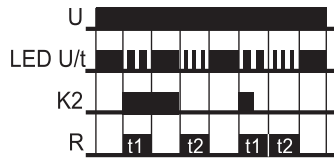

the output relay R switches into on-position (yellow LED illuminated) and the set interval t1 begins (green LED U/t flashes slowly). After the interval t1 has expired, the output relay R switches into off-position (yellow LED not illuminated).

If the control contact is opened, the output relay again switches into on-position (yellow LED illuminated) and the set interval t2 begins (green LED U/t flashes fast). After the interval t2 has expired the output relay switches into off-position (yellow LED not illuminated). During the interval, the control contact can be operated any number of times.

I3 - Pulse detection

When the supply voltage U (K1 closed) is applied, the set interval t1 begins (green LED U/t flashes slowly) and the output relay R switches

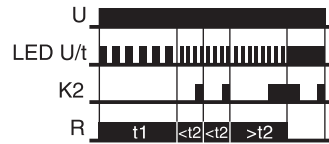

into on-position (yellow LED illuminated). After the interval t1 has expired, the set interval t2 begins (green LED U/t flashes fast). For the output relay to remain in on-position, the control contact K2 must be closed and reopened within the set interval t2. If this does not occur, the output relay R switches into off-position (yellow LED not illuminated) and all further pulses at the control contact K2 are ignored. To restart the function, the supply voltage must be interrupted and reapplied.

Connection

MFT ST22S

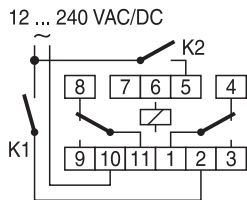

Load limit curve

MFT ST22S

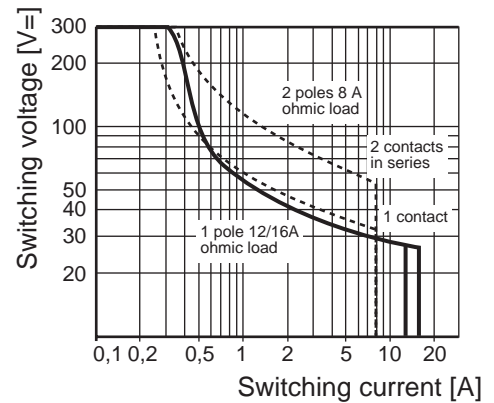

Dimensions

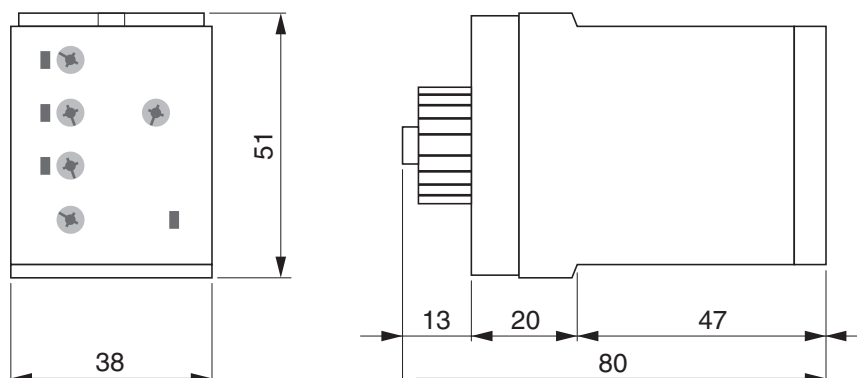

Multifunctional clock-pulse generator relay with external potentiometer

MFT ST51SE

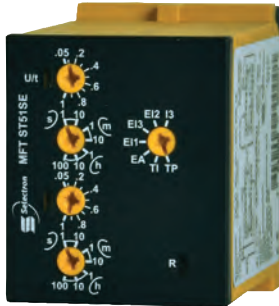

MFT ST51SE

- **7 Function, 7 timer ranges**
- **Multivoltage:**
24 VAC/DC and 110 ... 240 VAC
- **2 Output contacts**

Functions

- TP** Cycling timer relay beginning on a pause
- TI** Cycling timer relay beginning on a pulse
- EA** Delay on and delay off
- EI1** Input delay pulse limitation timer voltage control
- EI3** Input delay pulse limitation with control contact
- EI2** Wiping on leading and trailing edge with control contact
- I3** Pulse detection

Time end ranges

Adjustable 0,05 s ... 100 h

Output relay

1 closing contact and 1 opening contact potential free
250 VAC 5 A units close together 8 A units not close together

Indicators

- Green LED ON: indication of supply voltage
- Green LED flashes slowly: indication of time t1
- Green LED flashes fast: indication of time t2
- Yellow LED ON/OFF: indication of relay output

Connecting voltage

- 24 VDC $\pm 10\%$
- 24 VAC -15% ... +10%
- 110 ... 240 VAC -15% ... +10%

Reference data

Selectron® MFT	Article no.
MFT ST51SE	41140007
(Order data see chapter 1)	

Multifunctional clock-pulse generator relay with external potentiometer

MFT ST51SE

Technical data	
Nominal consumption	
24 VAC/DC	0.8 VA / 0.6 W
110 VAC	2.4 VA / 0.6 W
230 VAC	19 VA / 1.1 W
Control contact / Voltage controlled	
Parallel switching of loads possible	
Parallel minimum load	1 VA or 0.5 W
Voltage dependence:	The potential between connections 2 and 5, resp. 7 and 5, must cover 90% of the supply voltage.
Connecting length between connections 10 and 5:	10 m or capacity <10 nF
Resistance	>1 MΩ (contact K2 open)
Rest current at parallel load:	approx. 2 mA at contact K2 open
External Potentiometer 1 MΩ	Voltage on contact 3 and 6 resp. 6 and 8 24 VAC/DC resp. 110 ... 240 VAC Line length max. 5m (twisted pair)
Accuracy	
Base accuracy	±1% of scale limit ±5% if external Ppoteniometer is connected
Repeatability of the scale limit at constant conditions	±5% or ±100ms
Adjustment accuracy	<5%
Temperature influence	≤0.05% / °C
Reaction times	
Operating/return time K1	max. 60 ms / 30 ms
Reaction time K2	max. 30 ms
Min. pulse/pause time K2	AC 50 ms / dc 50 ms
Recovery time	max. 200 ms

Type key

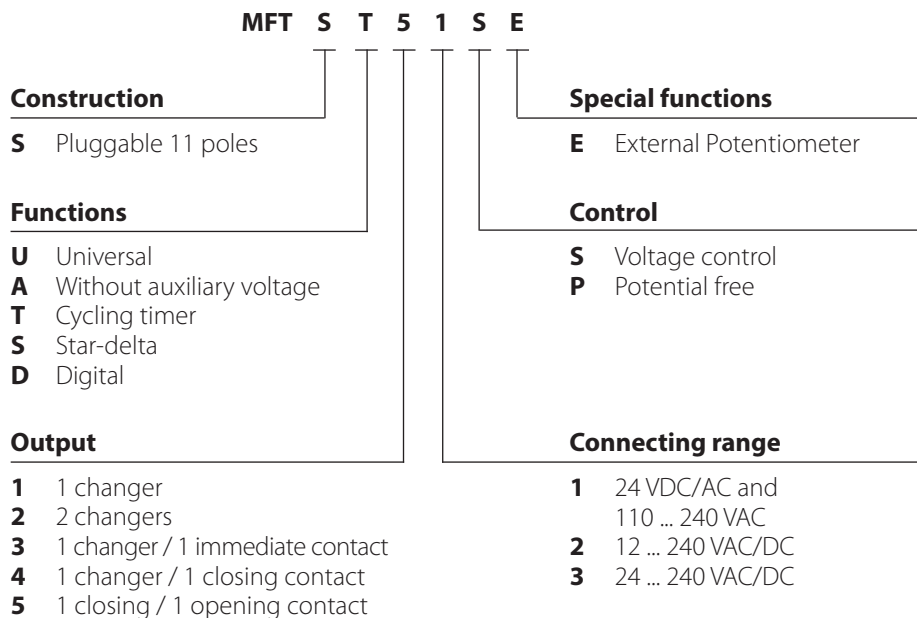

Multifunctional clock-pulse generator relay with external potentiometer

MFT ST51SE

Function descriptions

TP - Cycling timer relay beginning on a pause

When the supply voltage U (K1 closed) is applied, the set interval t1 begins (green LED U/t flashes slowly). After the



interval t1 has expired, the output relay switches into on-position (yellow LED illuminated) and the set interval t2 begins (green LED U/t flashes fast). After the interval t2 has expired, the output relay switches into off-position (yellow LED not illuminated).

The output relay is triggered in the ratio of the two set intervals until the supply voltage U (K1 opened) is interrupted.

TI - Cycling timer relay beginning on a pulse

When the supply voltage U (K1 closed) is applied, the output relay R switches into on-position (yellow LED illuminated)



and the set interval t1 begins (green LED U/t flashes slowly). After the interval t1 has expired, the output relay switches into off-position (yellow LED not illuminated) and the set interval t2 begins (green LED U/t flashes fast). After the interval t2 has expired, the output relay switches into on-position again (yellow LED illuminated).

The output relay is triggered in the ratio of the two set intervals until the supply U (K1 opened) voltage is interrupted.

EA - Delay on and delay off

The supply voltage U (K1 closed or permanently connected) must be constantly applied to the device (green LED U/t

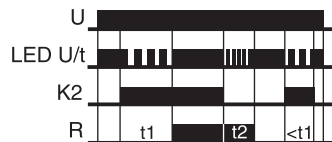

illuminated). When the control contact K2 is closed, the set interval t1 begins (green LED U/t flashes slowly). After the interval t1 has expired, the output relay R switches into on-position (yellow LED illuminated). When the control contact K2 is opened, the set interval t2 begins (green LED U/t flashes fast). After the interval t2 has expired, the output relay switches into off-position (yellow LED not illuminated).

If the control contact K2 is opened before the interval t1 has expired, the interval already expired is erased and is restarted with the next cycle.

E11 - Input delay pulse limitation timer voltage control

When the supply voltage U (K1 closed) is applied, the set interval t1 begins (green LED U/t flashes slowly). After the interval t1 has

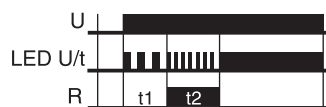

expired, the output relay switches into on-position (yellow LED illuminated) and the set interval t2 begins (green LED U/t flashes fast). After the interval t2 has expired, the output relay switches into off-position (yellow LED not illuminated). If the supply voltage is interrupted before the interval t1+t2 has expired, the interval already expired is erased and is restarted when the supply voltage is next applied.

E13 - Input delay pulse limitation timer with control contact

The supply voltage U (K1 closed) must be constantly applied to the device (green LED U/t illuminated). When the control contact K2

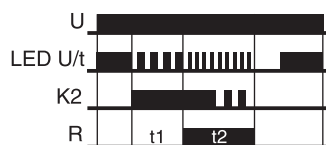

is closed, the set interval t1 begins (green LED U/t flashes slowly). After the interval t1 has expired, the output relay switches into on-position (yellow LED illuminated) and the set interval t2 begins (green LED U/t flashes fast). After the interval t2 has expired, the output relay switches into off-position (yellow LED not illuminated). During the interval, the control contact K2 can be operated any number of times. A further cycle can only be started when the cycle run has been completed.

E12 - Wiping on leading and trailing edge with control contact

The supply voltage U must be constantly applied to the device (green LED U/t illuminated). When the control contact K2 is closed,

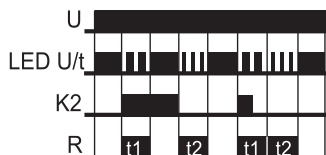

the output relay R switches into on-position (yellow LED illuminated) and the set interval t1 begins (green LED U/t flashes slowly). After the interval t1 has expired, the output relay R switches into off-position (yellow LED not illuminated).

If the control contact is opened, the output relay again switches into on-position (yellow LED illuminated) and the set interval t2 begins (green LED U/t flashes fast). After the interval t2 has

Multifunctional clock-pulse generator relay with external potentiometer

MFT ST51SE

Function descriptions

expired the output relay switches into off-position (yellow LED not illuminated). During the interval, the control contact can be operated any number of times.off-position (yellow LED not illuminated). During the interval, the control contact can be operated any number of times.

I3 - Pulse detection

When the supply voltage U (K1 closed) is applied, the set interval t1 begins (green LED U/t flashes slowly) and the output relay R switches into

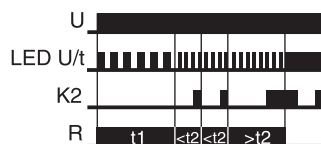

on-position (yellow LED illuminated). After the interval t1 has expired, the set interval t2 begins (green LED U/t flashes fast). For the output relay to remain in on-position, the control contact K2 must be closed and reopened within the set interval t2. If this does not occur, the output relay R switches into off-position (yellow LED not illuminated) and all further pulses at the control contact K2 are ignored. To restart the function, the supply voltage must be interrupted and reapplied.

Connection

MFT ST51SE

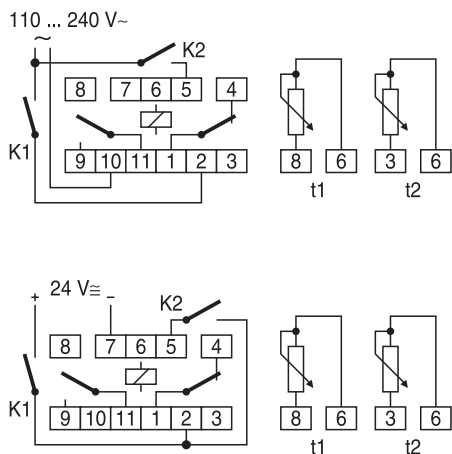

Load limit curve

MFT ST51SE

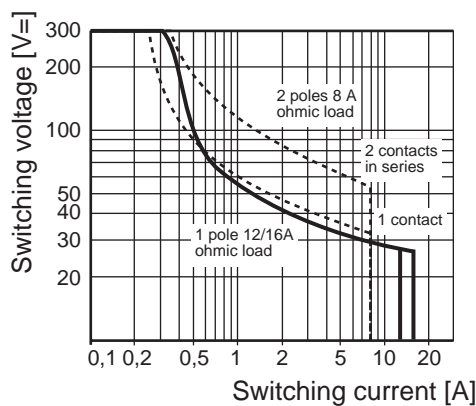

Dimensions

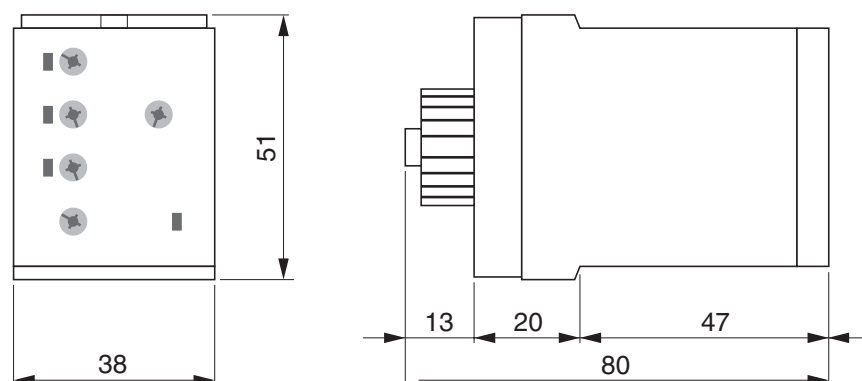

Delay off without supply voltage

MFT SA23S



MFT SA23S

- **5 Function, 4 time ranges**
- **Multivoltage:**
24 ... 240 VAC/DC
- **2 Output contacts**

Functions

- E** On delay
- A** Off delay without auxiliary voltage
- W2** Wiping on trailing edge voltage control (non-resetting on voltage failure)
- I1** Pulse limitation timer voltage control (non-resetting on voltage failure)
- W3** Wiping on leading and trailing edge voltage control (non-resetting on voltage failure)

Time end ranges

Adjustable 0,1 s ... 3 min.

Output relay

2 changers potential free
250 VAC / 8 A

Indicators

Green LED ON: indication of supply voltage

Connecting voltage

24 ... 240 VAC/DC, ac: -15% +10%, dc: -10% +10%
48 ... 63 Hz, 100% duration of operation, IEC class 1c

Reference data

Selectron® MFT	Article no.
MFT SA23S	41140008
(Order data see chapter 1)	



Note:

After transport the output relay maybe in any position.
The correct operation will be given after the first cycle.

Delay off without supply voltage

MFT SA23S

Technical data		
Nominal consumption		
AC		1 VA / 0.5 W
DC		0.7 VA / 0.7 W
Accuracy		
Base accuracy		± 1% of scale limit ≤ 10% for time range 1s
Repetition accuracy		1% or 100 ms
Adjustment accuracy		< 5% of scale limit
Temperature influence		≤ 0,02% / °C
Reaction time		
Recovery time		100 ms

Type key

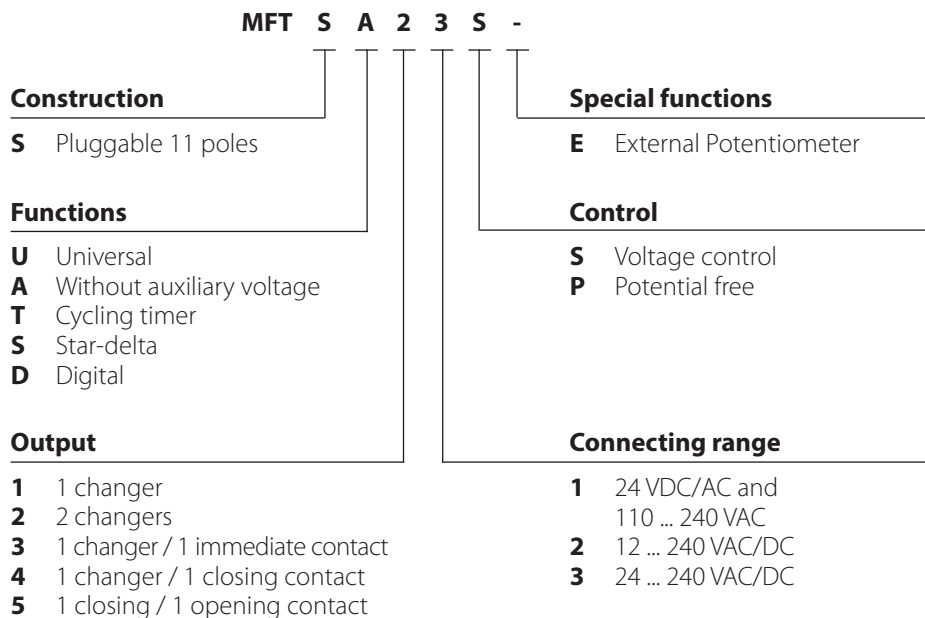

Delay off without supply voltage

MFT SA23S

Function descriptions

E - On delay

Activation by U_s via K1. When K1 closes, the set interval t begins (green LED U illuminated).



After the interval t has elapsed, the output relay picks up and remains in the working position until K1 is opened again. Interrupting U_s during the interval t causes a reset.

A - Off delay

Activation by U_s via K1. The output relay picks up after K1 closes. If K1 is opened again, the set interval t begins (green LED U not illuminated).



After the interval t has elapsed, the output relay drops back out to its rest position. Operating K1 during the interval t causes a time reset.

I1 - Pulse limitation timer voltage control

Activation by U_s via K1. When K1 closes, the output relay picks up immediately and the set interval t begins (green LED U illuminated).



After the interval t has elapsed, the output relay drops back out to its rest position. This condition is maintained until U_s is interrupted. Interrupting U_s before the interval t has elapsed means that the output relay remains picked up until the interval t has fully elapsed.

W2 - Wiping on trailing edge voltage control

Activation by U_s via K1. The output relay remains dropped out after K1 closes. As soon as K1 is opened, the output relay picks up and the set interval t begins (green LED U not illuminated).



After the interval t has elapsed, the output relay drops out. Closing K1 before the interval t has elapsed means that the output relay remains picked up until the interval t has fully elapsed.

W3 - Wiping on leading and trailing edge voltage control

Activation by U_s via K1. When K1 closes, the output relay picks up and the set interval t begins (green LED U illuminated).



After the interval t has elapsed, the output relay drops out. As soon as K1 is opened, the output relay picks up and the set interval t begins (green LED U not illuminated).

After the interval t has elapsed, the output relay drops out. Interrupting or re-applying U_s before the interval t has elapsed means that the output relay remains picked up until the interval t has fully elapsed.

Delay off without supply voltage

MFT SA23S

Connection

MFT SA23S

24 ... 240 VAC/DC

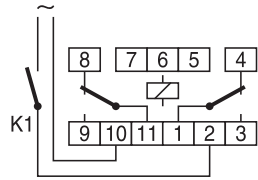

Load limit curve

MFT SA23S

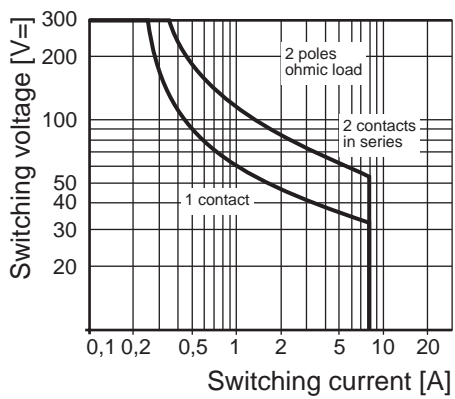

Dimensions

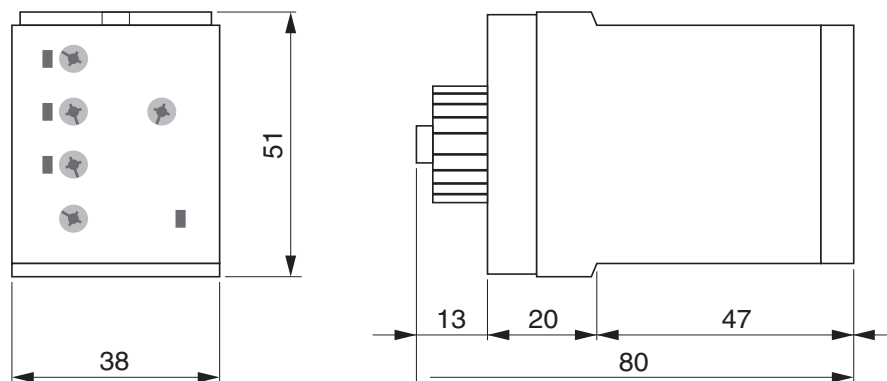

Star-delta relay

MFT SS22S

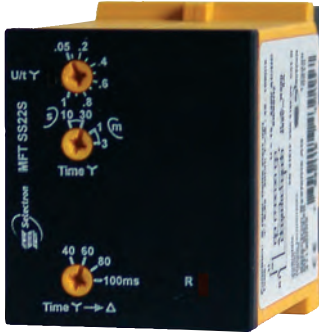

MFT SS22S

- **1 Function, 4 time ranges**
- **Multivoltage:**
12 ... 240 VAC/DC
- **2 Output controls**

Functions

S Star-delta

Time end ranges

Star times 500 ms - 10 s, 1,5 s - 30 s, 3 s - 1 min., 9 s - 3 min.

Change over time 40 ms, 60 ms, 80 ms, 100 ms

Output relay

2 potential free change over contacts

250 VAC 8 A

Indicators

Green LED ON: indication of supply voltage

Green LED flashes: indication of time period - start-up time

Yellow LED ON/OFF: indication of star-contactor

Connecting voltage

12 ... 240 VAC/DC -10% +10%

48 ... 63 Hz, 100% duration of operation, IEC class 1c

Reference data

Selectron® MFT	Article no.
MFT SS22S	41140009
(Order data see chapter 1)	

Star-delta relay

MFT SS22S

Technical data	
Nominal consumption	
12 ... 240 VAC/DC	6 VA / 2 W
Residual ripple to dc	10%
Dop-out voltage	> 30% of the supply voltage
Accuracy	
Repetition accuracy	±5 ms or <0.5%
Adjustment accuracy	<5%
Temperature influence	≤0.01% / °C
Base accuracy	±1% of scale limit
Voltage influence	–
Reaction time	
Recovery time	100 ms

Type key

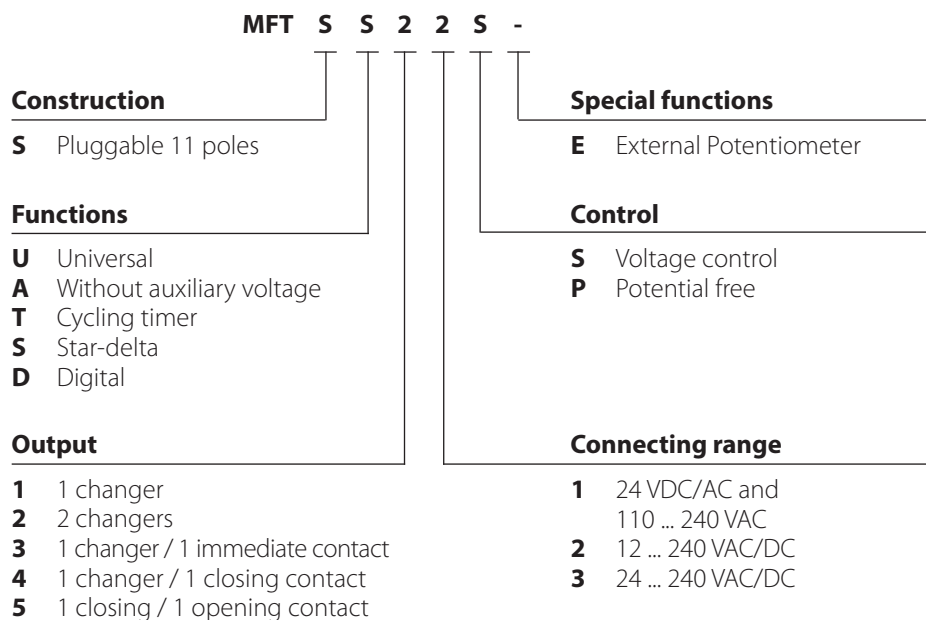

Star-delta relay

MFT SS22S

Function descriptions

S - Star-delta start-up

When the supply voltage U is applied, the star-contact switches into on-position (yellow LED illuminated) and the set star-time Y begins (green LED U/t flashes).

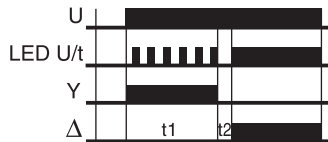

After the interval Y has expired (green LED U/t illuminated) the star-contact switches into off-position (yellow LED not illuminated) and the set transit-time ($Y \rightarrow \Delta$) begins. After the interval Δ has expired the contact for the delta-contactor switches into on-position (green LED U/t illuminated). To restart the function the supply voltage must be interrupted and re-applied.

Connection

SS22S

12 ... 240 VAC/DC

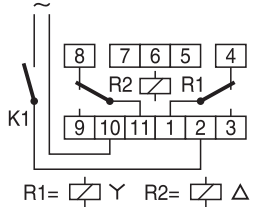

Load limit curve

MFT SS22S

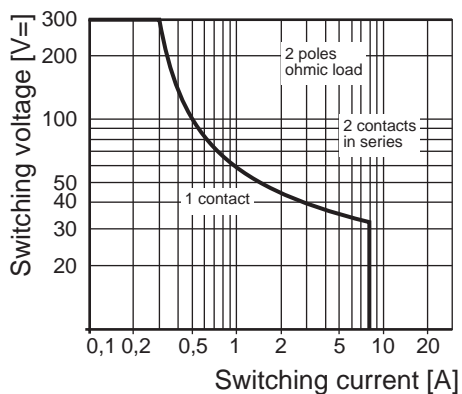

Star-delta relay

MFT SS22S

Dimensions

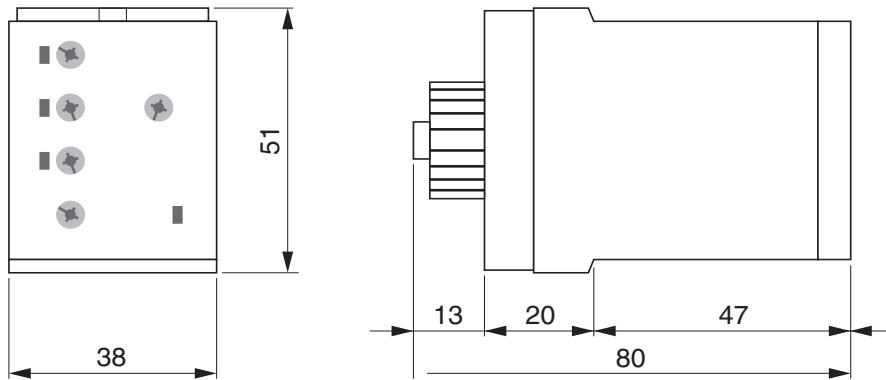

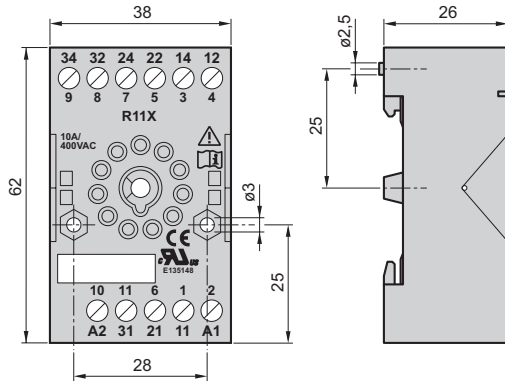
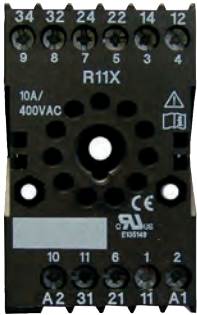

Plug in socket

Plug in socket 11 poles	Article no.
SSK 11 N	41910006
(Order data see chapter 1)	

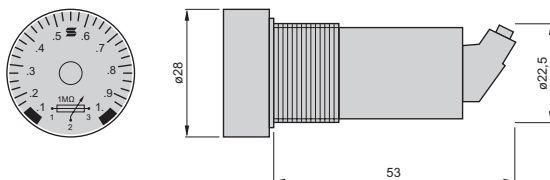

Potentiometer EXPOT 1	
Resistor	1 MΩ
Angle of rotation	295 °
Front protection	IP 64
Mounting diameter	22,5 mm
Connection	Screw terminals
Article no.	41920034
(Order data see chapter 1)	

Technical safety advice

This manual contains the information necessary for the correct utilisation of the products described therein. It is intended for technically qualified persons who are involved as either

- planning engineers familiar with the safety concepts of automation technology;
- or, operating personnel, who have been instructed in handling automation equipment and have a knowledge of the contents of this manual concerning operation;
- or, installation and servicing personnel possessing the necessary training to repair such an automation system or who have the authority to put such circuits and equipment/systems into operation, to earth or label them according to the relevant safety standards.

The products are constructed, manufactured and tested in compliance with the relevant VDE standards, VDE specifications and IEC recommendations.

Danger warning

These warnings serve both as a guide for those persons involved in a project and as safety advice to prevent damage to the products themselves or to associated equipment.

Due to advancements in technology, the wiring diagram on the actual device may be different than shown in this catalogue. In all instances where the actual device diagram is different, the wiring diagram on the device must be used when electrical connections are made.

Correct utilisation, configuration and assembly

The equipment is to be used only for the applications stated in the catalogue and technical literature, and only in conjunction with auxiliary equipment and devices that are recommended or approved by Selectron Systems Ltd.

Further, it should be noted that:

- the automation equipment must be disconnected from any power supply before it is assembled, disassembled or the configuration modified.
- Solid state electronic switches must not be tested with incandescent lamps or connected to a load that exceeds its rating.
- trouble-free and safe operation of the products requires correct transportation as well as appropriate storage, assembly and wiring.

- the systems may only be installed by trained personnel. In doing so, the relevant requirements contained in VDE 0100, VDE 0113, IEC 364, etc. must be complied with.

Prevention of material damage or personal injury

Additional external safety devices or facilities must be provided wherever significant material damage or even personal injury could result from a fault occurring in an automation system. A defined operating status must be ensured or forced by such devices or facilities (e.g. by independent limit switches, mechanical interlocks, etc.).

Advice concerning planning and installation of the products

- The safety and accident prevention measures applicable to a specific application are to be observed.
- In the case of mains-operated equipment, a check is to be made before putting it into operation to ensure that the preset mains voltage range is suitable for the local supply.
- In the case of a 24 V supply, care must be taken to ensure sufficient electrical insulation of the secondary side. Use only mains power supply units that conform to IEC 364-4-41 or HD 384.04.41 (VDE 0100 Part 410).
- Automation systems and their operating elements are to be installed in such a way that they are sufficiently protected against accidental operation.

Warranty

Selectron Systems Ltd. warrants its products to be free from defects in material and workmanship for a period of one year from the date of shipment. All claims under this warranty must be made within thirty (30) days of the discovery of the defect, and all defective products must be returned at the buyer's expense. Buyer's sole and exclusive right will be limited to, at the option of Selectron Systems Ltd., the repair or replacement by Selectron Systems Ltd., of any defective products for which a claim is made.

In all other matters please refer to the „General terms of business“ concerning Selectron Systems Ltd.

Note

The information given in this documentation corresponds to the state of development at the time of going to press and is therefore not binding. Selectron Systems Ltd. reserves the right to make alterations in the interests of technical advancement or product improvement at any time without giving reasons for doing so.

Prescriptions and standards

Mechanical data

Housings in self-extinguishing plastic material. Protection mode IP 40

Mounting: snapping mode: Fixing on profile rail TS 35 according to EN 60715

Connection via contact protected terminals up to 4 mm², protecting mode IP 20

Mounting: plugable mode: Fixing and connection via 11 pole screw or soldering plug socket

Pin arrangement and connection mark according to IEC67-1-18a

Environmental conditions

Admissible environmental temperatures from -25 °C ... +55 °C according to 60068-1

Storage and transport temperature from -25 °C ... +70 °C

Climatic conditions according to IEC 60721-3-3 class 3K3

Output relay

Electrical lifetime: 250 VAC, 2 x 10⁵ switching cycles at 1000 VA resistive load

Mechanical lifetime: 20 x 10⁶ switching cycles

Contact material AgNi 0,15

Supply voltage

Frequency range 48 ... 63 Hz

Duty cycle 100%, IEC class 1c

Protection

Protection of the unit 8 A fast

Terminals

Contact protection according to VDE 0106 and VBG 4

Terminal arrangement and connecting mark according to DIN 46 199

Terminal type: sleeve with indirect screw pressure

Wire to connect: rigid or flexible

Connecting limit: 4 mm²

Terminal variants: 1 wire 0,5 mm² ... 2,5 mm² with/without wire end covers

1 wire 4 mm² without wire end covers

2 wires 0,5 mm² ... 1,5 mm² with/without wire end covers

2 wires 2,5 mm² flexible without wire end covers

max. screw in torque: 1,0 Nm

Terminal screw for screw driver or Pozi drive PZ-1

Insulation

Isolation nominal voltage: 250 VAC according to IEC 60664-1

Rating surge voltage: 4 kV, over-voltage category III, according to IEC 60664-1

Electromagnetic compatibility

Electrostatic discharge: Level 3, 6 kV contact, 8 kV air, according to IEC 61000-4-2

High frequency electromagnetic fields: Level 3, 10 V/m, according to IEC 61000-4-4

Fast transients: Level 4, 4 kV / 2,5 kHz, 5/50 ns, according to IEC 61000-4-3

Lightning discharge: Level 3, 2 kV com., 1 kV dif., according to IEC 61000-4-5

Cable running disturbances inducted by HF fields: Level 3, 10 V RMS, according to IEC 61000-4-6)

Spurious radiation net and aerial network: Class A, according to CISPR 22)

Prescriptions

Air and leakage paces: IEC 61812-1

Test voltage: IEC 61812-1 1640 VAC

Low voltage directions according to IEC 61812-1

EMC emissions: according to IEC 61812-1 class A

EMC interference stability: Voltage impact strength according to IEC 61000-4-5

Burst: according to IEC 61812-1 (level 3)

ESD: according to IEC 61000-4-2

HF over metallic circuits: according to IEC 61812-1

Electro magnetic HF field according to IEC 61812-1

Production standard: according to ISO 9001

Timer relays

Content

Multifunction timer relays mounting position

Multifunctional time delay relay	
MFT IQ13S.....	2
Technical data.....	3
Function descriptions.....	4
Connection	5
Multifunctional time delay relay	
MFT IU14S, IU24S.....	6
Technical data.....	7
Function descriptions.....	8
Connection	9
Clock-pulse generator time delay relay	
MFT IT14S	10
Technical data.....	11
Function descriptions.....	12
Connection	13
Multifunction clock-pulse generator relay	
MFT ITU24S.....	14
Technical data.....	15
Function descriptions.....	16
Connection	17
Technical safety advice	18
Prescriptions and standards.....	19

Edition 05.07

Subject to technical changes and amendments to technical specifications at any time

Multifunctional time delay relay

MFT IQ13S



MFT IQ13S

- **4 functions**
- **Zoomvoltage:**
24 ... 240 Vac/dc
- **1 output contact**

Function

Q 4-functions

- E** Delay on
- A** Delay off
- I1** Pulse limitation timer voltage control
- B2** Cycling timer starting on a pause

Time ranges

Adjustable 0,05 s ... 100 h

Output relay

1 changer potential free 250 Vac / 8 A

Indicators

- Green LED ON: indication of supply voltage
- Green LED flashes: indication of time
- Yellow LED ON/OFF: indication of relay output

Supply voltage

24 ... 240 Vac/dc -15% +10%

AC 48 ... 63 Hz, 100% duration of operation

Reference data

Selectron® MFT	Article no.
MFT IQ13S	41130001
(Order data see chapter 1)	

Multifunction time delay relay

MFT IQ13S

Technical data	
Input circuit	MFT IQ13S
	24 ... 240 Vac/dc 4 VA / 1,5 W
	Residual ripple for dc 10%
	Drop-out voltage >30% of minimum rated supply voltage
Control contact / Voltage controlled	
	Parallel switching of loads possible
	Input not potential free terminals A1 - B1
	Trigger level (sensitivity) automatic adapted to supply voltage
	Max. line length 10 m
	Min. control pulse length DC 50 ms / AC 100 ms
Accuracy	
	Base accuracy ±1% of the scale limit
	Repeatability of the scale limit <0,5% or ±5 ms
	Adjustment accuracy <5% of the scale limit
	Temperature influence ≤0,01% / °C
Reaction times	
	Recovery time 100 ms

Type key

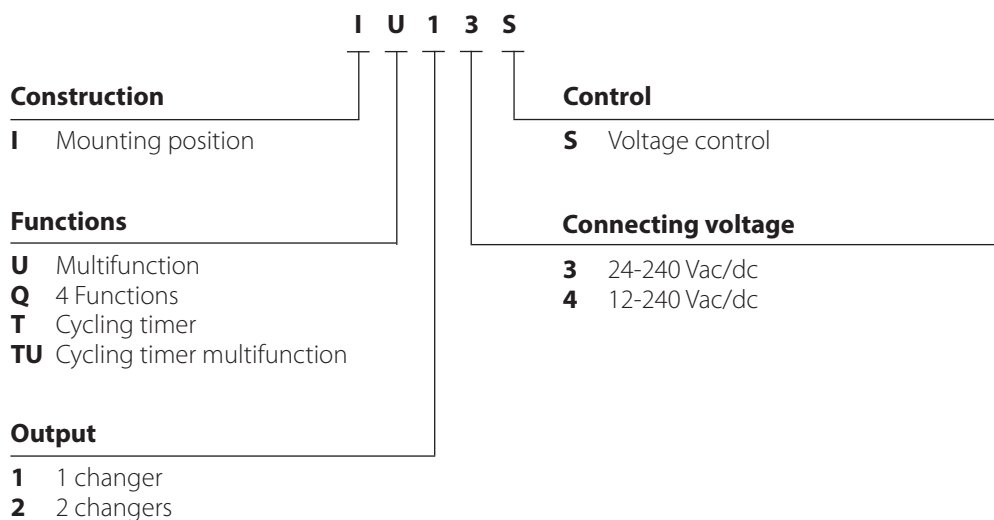

Multifunctional time delay relay

MFT IQ13S

Function descriptions

E - Delay on

When the supply voltage U is applied, the set interval t begins (green LED U/t flashes). After the interval t has expired



(green LED U/t illuminated) the output relay switches into on-position (yellow LED illuminated). This status remains until the supply voltage U is interrupted. If the supply voltage U is interrupted before expiry of the interval t, the interval already expired is erased and is restarted when the supply voltage U is next applied.

A - Delay off

The supply voltage U must be constantly applied to the device (green LED U/t illuminated). When the control con-

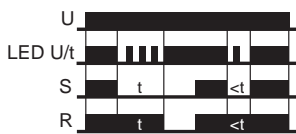

tact S is closed, the output relay R switches into on-position (yellow LED illuminated). If the control contact S is opened, the set interval t begins (green LED U/t flashes). After the interval t has expired (green LED U/t illuminated) the output relay switches into off-position (yellow LED not illuminated). If the control contact is closed again before the interval t (green LED U/t illuminated) has expired, the interval already expired is erased and is restarted with the next cycle.

I1 - Pulse limitation timer voltage control

When supply voltage U is applied, the output relay R switches into on-position (yellow LED illuminated) and the set



interval t begins (green LED U/t flashes). After the interval t has expired (green LED U/t illuminated) the output relay switches into off-position (yellow LED not illuminated). This status remains until the supply voltage is interrupted. If the supply voltage is interrupted before the interval t has expired, the output relay switches into off-position. The interval already expired is erased and is restarted when the supply voltage is next applied.

B2 - Cycling timer starting on a pause

When the supply voltage U is applied, the set interval t begins (green LED U/t flashes). After the interval t has expired, the output

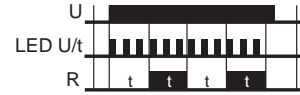

relay R switches into on-position (yellow LED illuminated) and the set interval t begins again. After the interval t has expired, the output relay switches into off-position (yellow LED not illuminated). The output relay is triggered in the ratio 1:1 until the supply voltage is interrupted.

Multifunction time delay relay

MFT IQ13S

Connection

MFT IQ13S

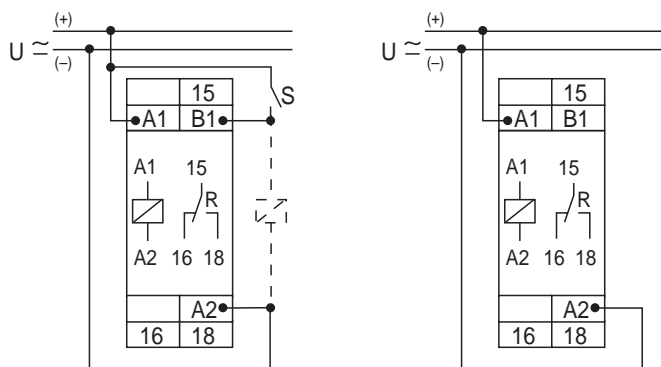

Load limit curves

MFT IQ13S

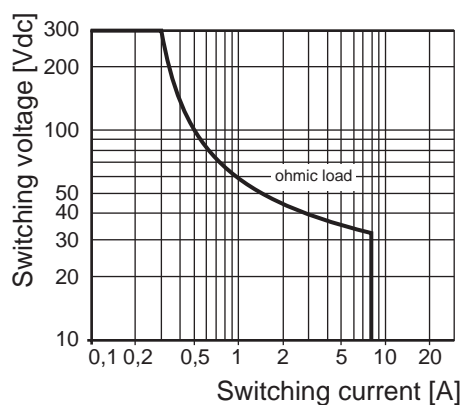

Dimensions

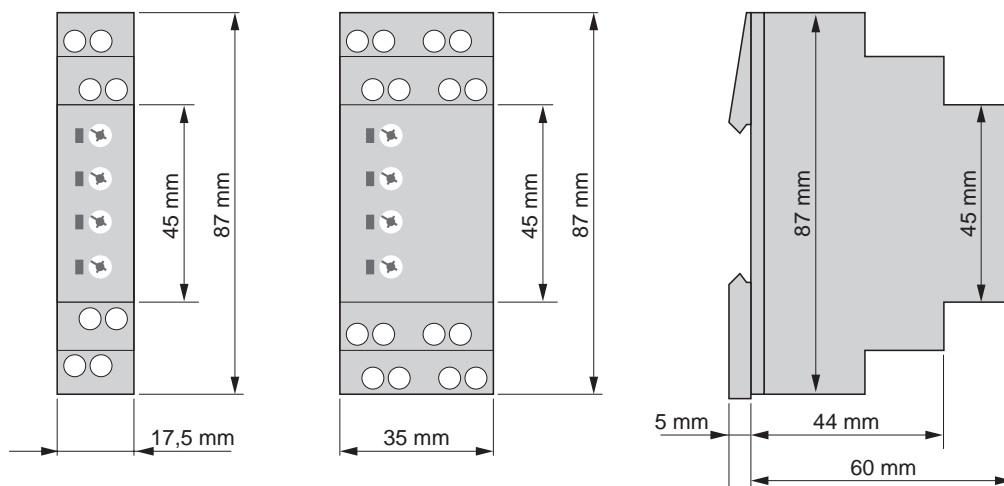

Multifunction time delay relay

MFT IU14S, IU24S



MFT IU14S

- 7 functions
- Zoomvoltage:
12 ... 240 Vac/dc
- 2 output contacts

Function

U Multifunction

- E** Delay on
- A** Delay off
- I2** Pulse extension with control contact
- W2** Wiping on trailing edge
- E1** Delay on with control contact
- I1** Pulse limitation timer voltage control
- B2** Cycling timer starting on a pause



MFT IU24S

Time ranges

Adjustable 0,05 s ... 100 h

Output relay

1 or 2 changers potential free 250 Vac / 8 A

Indicators

- Green LED ON: indication of supply voltage
- Green LED flashes: indication of time
- Yellow LED ON/OFF: indication of relay output

Supply voltage

12... 240 Vac/dc -10% +10%

AC 48 ... 63 Hz, 100% duration of operation

Reference data

Selectron® MFT	Article no.
MFT IU14S	41130003
MFT IU24S	41130004
(Order data see chapter 1)	

Multifunction time delay relay

MFT IU14S, IU24S

Technical data	
Input circuit	MFT IU143S, IU24S
	12 ... 240 Vac/dc IU14S: 4 VA / 1,5 W IU24S: 6 VA / 2 W
	Residual ripple for dc 10%
	Drop-out voltage >30% of minimum rated supply voltage
Control contact / Voltage controlled	
	Parallel switching of loads possible
	Input not potential free terminals A1 - B1
	Trigger level (sensitivity) automatic adapted to supply voltage
	Max. line length 10 m
	Min. control pulse length DC 50 ms / AC 100 ms
Accuracy	
	Base accuracy ±1% of the scale limit
	Repeatability of the scale limit <0,5% or ±5 ms
	Adjustment accuracy <5% of the scale limit
	Temperature influence ≤0,01% / °C
Reaction times	
	Recovery time 100 ms

Type key

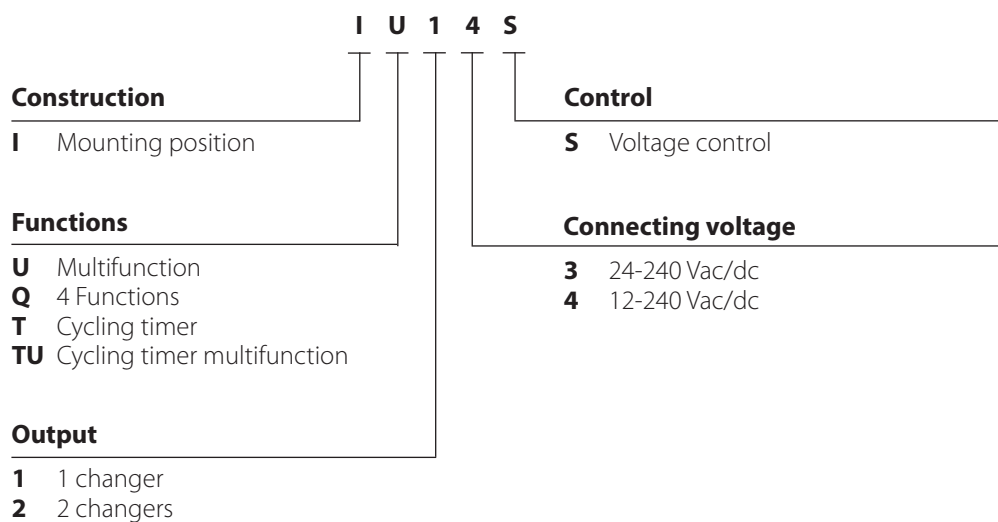

Multifunctional time delay relay

MFT IU14S, IU24S

Function descriptions

E - Delay on

When the supply voltage U is applied, the set interval t begins (green LED U/t flashes). After the interval t has expired



(green LED U/t illuminated) the output relay switches into on-position (yellow LED illuminated). This status remains until the supply voltage U is interrupted. If the supply voltage U is interrupted before expiry of the interval t, the interval already expired is erased and is restarted when the supply voltage U is next applied.

A - Delay off

The supply voltage U must be constantly applied to the device (green LED U/t illuminated). When the control con-

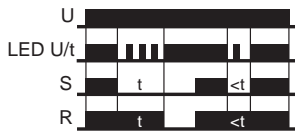

tact S is closed, the output relay R switches into on-position (yellow LED illuminated). If the control contact S is opened, the set interval t begins (green LED U/t flashes). After the interval t has expired (green LED U/t illuminated) the output relay switches into off-position (yellow LED not illuminated). If the control contact is closed again before the interval t (green LED U/t illuminated) has expired, the interval already expired is erased and is restarted with the next cycle.

I2 - Pulse extension with control contact

The supply voltage U must be constantly applied to the device (green LED U/t illuminated). When the control con-

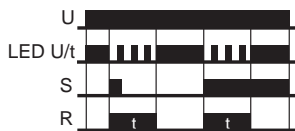

tact S is closed, the output relay R switches into on-position (yellow LED illuminated) and the set interval t begins (green LED U/t flashes). After the interval t has expired (green LED U/t illuminated) the output relay switches into off-position (yellow LED not illuminated). During the interval, the control contact can be operated any number of times. A further cycle can only be started when the cycle run has been completed.

W2 - Wiping on trailing edge

The supply voltage U must be constantly applied to the device (green LED U/t illuminated). Closing the control contact S has no influence on the condition of the output relay R. When the control contact is opened, the output relay switches into on-position (yellow LED illuminated) and the

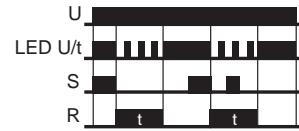

set interval t begins (green LED U/t flashes). After the interval t has expired (green LED U/t illuminated), the output relay switches into off-position (yellow LED not illuminated). During the interval, the control contact can be operated any number of times. A further cycle can only be started when a cycle run has been completed.

E1 - Delay on with control contact

The supply voltage U must be constantly applied to the device (green LED U/t illuminated).When the control contact



S is closed, the set interval t begins (green U/tLED flashes). After the interval t has expired (green LED U/t illuminated) the output relay R switches into on-position (yellow LED illuminated). This status remains until the control contact is opened. If the control contact is opened before the interval t has expired, the interval already expired is erased and is restarted with the next cycle.

I1 - Pulse limitation timer voltage control

When supply voltage U is applied, the output relay R switches into on-position (yellow LED illuminated) and the set

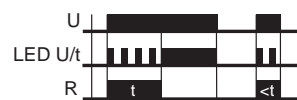

interval t begins (green LED U/t flashes). After the interval t has expired (green LED U/t illuminated) the output relay switches into off-position (yellow LED not illuminated). This status remains until the supply voltage is interrupted. If the supply voltage is interrupted before the interval t has expired, the output relay switches into off-position. The interval t already expired is erased and is restarted when the supply voltage is next applied.

B2 - Cycling timer starting on a pause

When the supply voltage U is applied, the set interval t begins (green LED U/t flashes). After the interval t has expired,



the output relay R switches into on-position (yellow LED illuminated) and the set interval t begins again. After the interval t has expired, the output relay switches into off-position (yellow LED not illuminated). The output relay is triggered in the ratio 1:1 until the supply voltage is interrupted.

Multifunctional time delay relay

MFT IU14S, IU24S

Connection

MFT IU14S

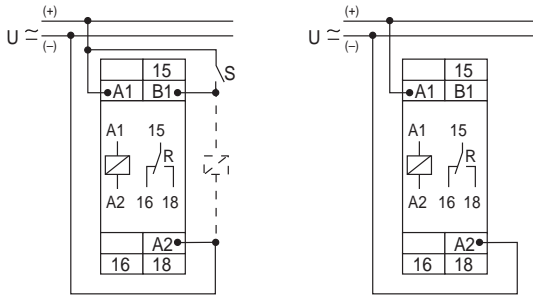

MFT IU24S

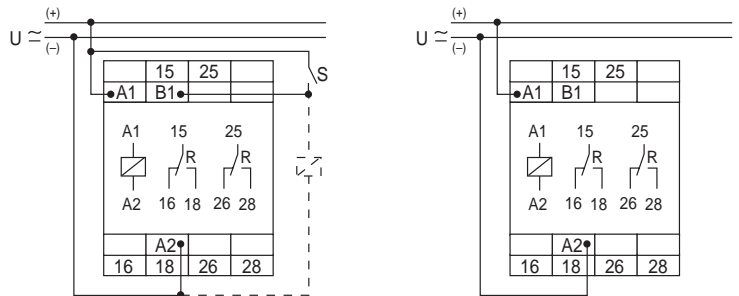

Load limit curves

MFT IU14S

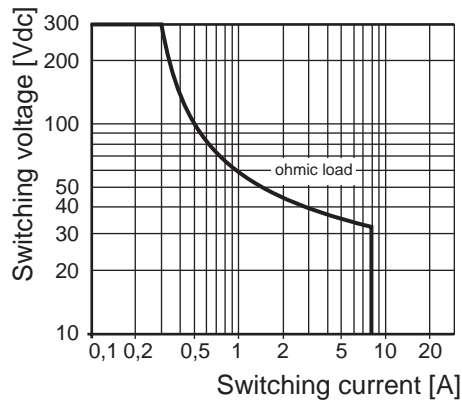

MFT IU24S

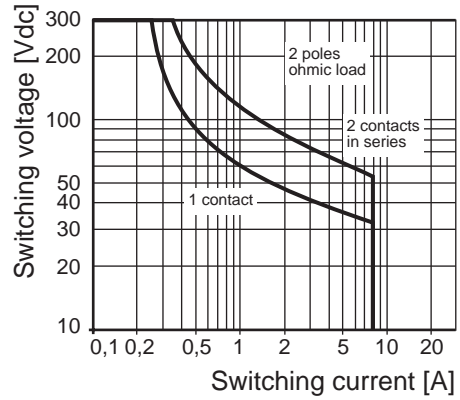

Dimensions

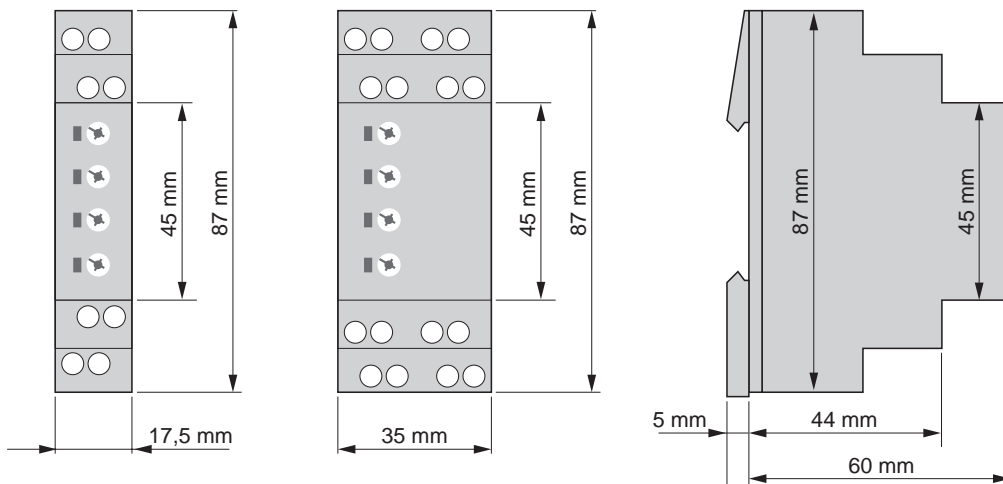

Clock-pulse generator time delay relay

MFT IT14S



MFT IT14S

- **2 functions**
- **Zoomvoltage:**
12 ... 240 Vac/dc
- **1 output contact**

Function

T Cycling timer

TP Cycling timer relay beginning on a pause

TI Cycling timer relay beginning on a pulse

Time ranges

Adjustable 0,05 s ... 100 h

Output relay

1 changer potential free 250 Vac / 8 A

Indicators

Green LED ON: indication of supply voltage

Green LED flashes slowly: indication of time t1

Green LED flashes fast: indication of time t2

Yellow LED ON/OFF: indication of relay output

Supply voltage

12 ... 240 Vac/dc -10% +10%

AC 48 ... 63 Hz, 100% duration of operation

Reference data

Selectron® MFT	Article no.
MFT IT14S	41130007
(Order data see chapter 1)	

Clock-pulse generator time delay relay

MFT IT14S

Technical data	
Input circuit	MFT IT14S
	12 ... 240 Vac/dc
	4 VA / 1,5 W
	Residual ripple for dc
	10%
	Drop-out voltage
	>30% of minimum rated supply voltage
Control contact / Voltage controlled	
	Parallel switching of loads possible
	Input not potential free
	terminals A1 - B1
	Trigger level (sensitivity)
	automatic adapted to supply voltage
	Max. line length 10 m
	Min. control pulse length
	DC 50 ms / AC 100 ms
Accuracy	
	Base accuracy
	±1% of the scale limit
	Repeatability of the scale limit
	<0,5% or ±5 ms
	Adjustment accuracy
	<5% of the scale limit
	Temperature influence
	≤0,01% / °C
Reaction times	
	Recovery time
	100 ms

Type key

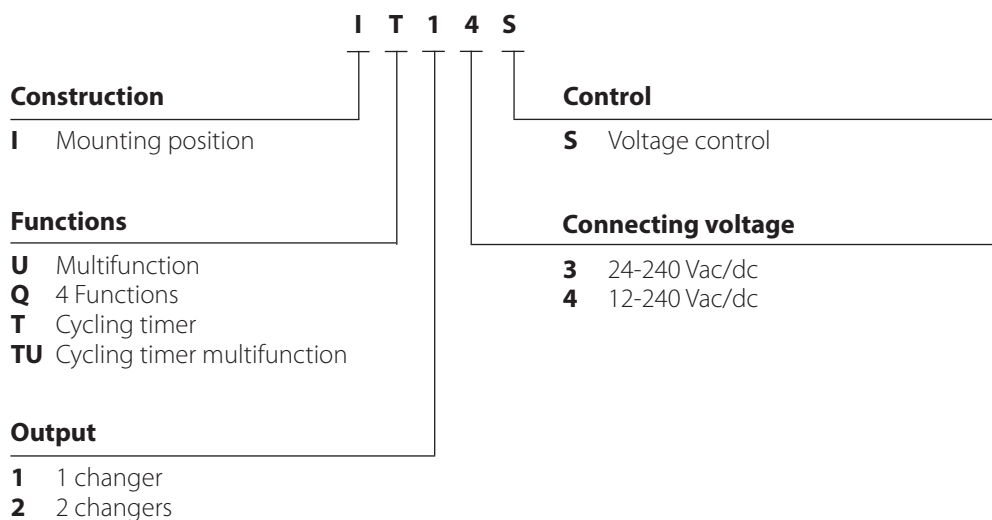

Clock-pulse generator time delay relay

MFT IT14S

Function descriptions

TP - Cycling timer relay beginning on a pause

When the supply voltage U is applied, the set interval t_1 begins (green LED U/t flashes slowly). After the interval t_1 has



expired, the output relay switches into on-position (yellow LED illuminated) and the set interval t_2 begins (green LED U/t flashes fast). After the interval t_2 has expired, the output relay switches into off-position (yellow LED not illuminated). The output relay is triggered in the ratio of the two set intervals until the supply voltage is interrupted.

TI - Cycling timer relay beginning on a pulse

When the supply voltage is applied, the output relay R switches into on-position (yellow LED illuminated) and the

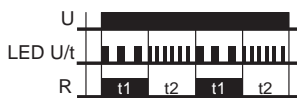

set interval t_1 begins (green LED U/t flashes slowly). After the interval t_1 has expired, the output relay switches into off-position (yellow LED not illuminated) and the set interval t_2 begins (green LED U/t flashes fast). After the interval t_2 has expired, the output relay switches into on-position again (yellow LED illuminated). The output relay is triggered in the ratio of the two set intervals until the supply voltage is interrupted.

Clock-pulse generator time delay relay

MFT IT14S

Connection

MFT IT14S

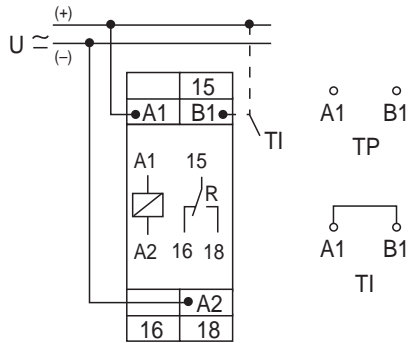

Load limit curves

MFT IT14S

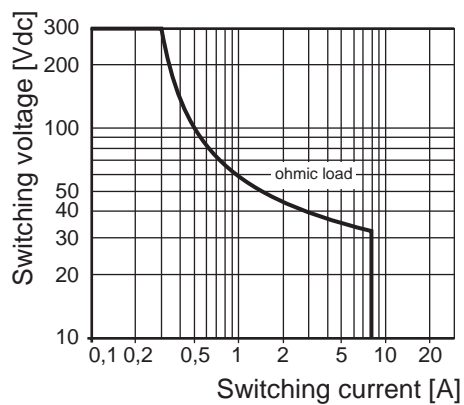

Dimensions

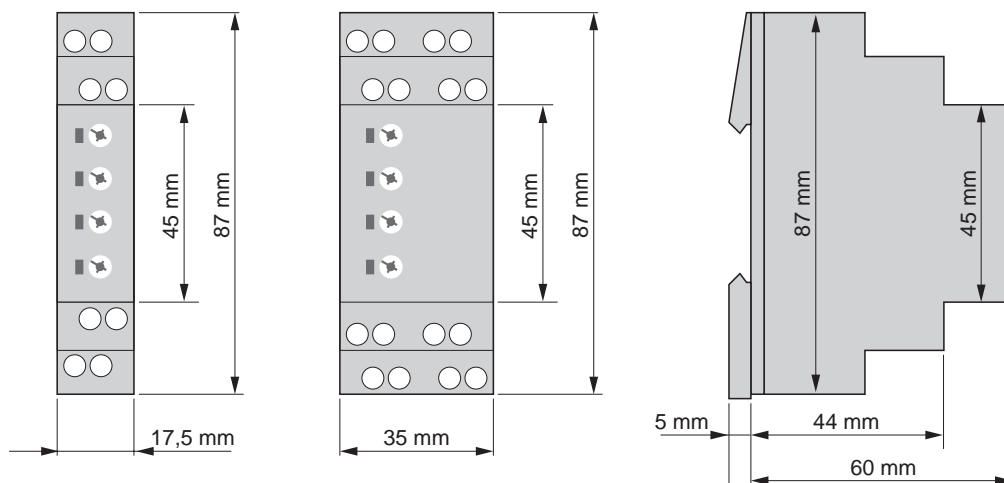

Multifunction clock-pulse generator relay

MFT ITU24S



MFT ITU24S

- **7 functions**
- **Zoomvoltage:**
12 ... 240 Vac/dc
- **2 output contacts**

Function

TU Cycling timer multifunction

- TP** Cycling timer relay beginning on a pause
- TI** Cycling timer relay beginning on a pulse
- EA** Delay on and delay off
- EI1** Input delay pulse limitation timer voltage control
- EI3** Input delay pulse limitation timer with control contact
- EI2** Input delay pulse with control contact
- I3** Pulse detection

Time ranges

Adjustable 0,05 s ... 100 h

Output relay

2 changers potential free 250 Vac / 8 A

Indicators

- Green LED ON: indication of supply voltage
- Green LED flashes slowly: indication of time t1
- Green LED flashes fast: indication of time t2
- Yellow LED ON/OFF: indication of relay output

Supply voltage

12 ... 240 Vac/dc -10% +10%
AC 48 ... 63 Hz, 100% duration of operation

Reference data

Selectron® MFT	Article no.
MFT ITU24S	41130005
(Order data see chapter 1)	

Multifunction clock-pulse generator relay

MFT ITU24S

Technical data	
Input circuit	MFT ITU14S
12 ... 240 Vac/dc	6 VA / 2 W
Residual ripple for dc	10%
Drop-out voltage	>30% of minimum rated supply voltage
Control contact / Voltage controlled	
Parallel switching of loads possible	
Input not potential free	terminals A1 - B1
Trigger level (sensitivity)	automatic adapted to supply voltage
Max. line length 10 m	
Min. control pulse length	DC 50 ms / AC 100 ms
Accuracy	
Base accuracy	±1% of the scale limit
Repeatability of the scale limit	<0,5% or ±5 ms
Adjustment accuracy	<5% of the scale limit
Temperature influence	≤0,01% / °C
Reaction times	
Recovery time	100 ms

Type key

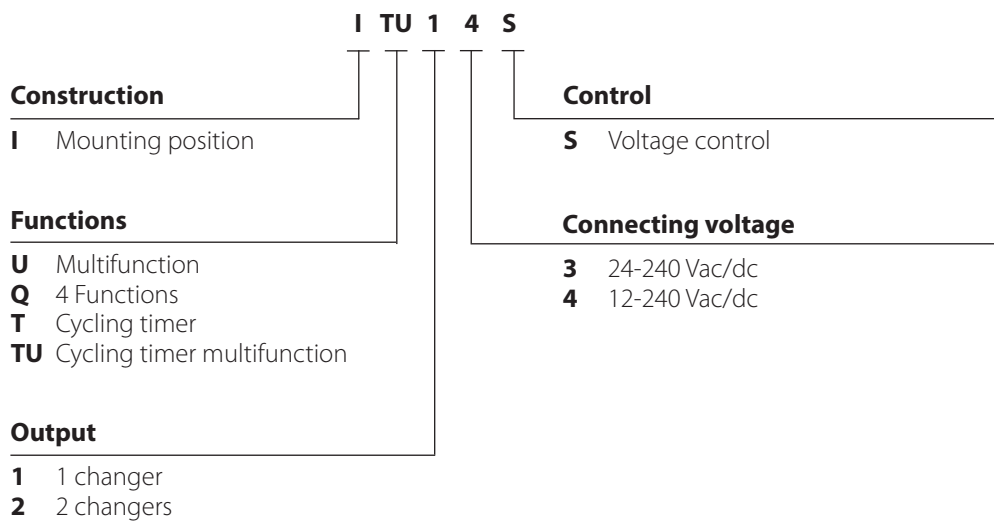

Multifunction clock-pulse generator relay

MFT ITU24S

Function descriptions

TP - Cycling timer relay beginning on a pause

When the supply voltage U is applied, the set interval t1 begins (green LED U/t flashes slowly). After the interval t1 has



expired, the output relay switches into on-position (yellow LED illuminated) and the set interval t2 begins (green LED U/t flashes fast). After the interval t2 has expired, the output relay switches into off-position (yellow LED not illuminated). The output relay is triggered in the ratio of the two set intervals until the supply voltage is interrupted.

TI - Cycling timer relay beginning on a pulse

When the supply voltage is applied, the output relay R switches into on-position (yellow LED illuminated) and the

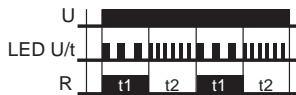

set interval t1 begins (green LED U/t flashes slowly). After the interval t1 has expired, the output relay switches into off-position (yellow LED not illuminated) and the set interval t2 begins (green LED U/t flashes fast). After the interval t2 has expired, the output relay switches into on-position again (yellow LED illuminated). The output relay is triggered in the ratio of the two set intervals until the supply voltage is interrupted.

EA -Delay on and delay off

The supply voltage U must be constantly applied to the device (green LED U/t illuminated). When the control contact

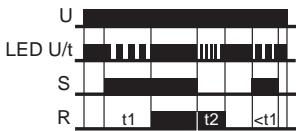

S is closed, the set interval t1 begins (green LED U/t flashes slowly). After the interval t1 has expired, the output relay R switches into on-position (yellow LED illuminated). When the control contact S is opened, the set interval t2 begins (green LED U/t flashes fast). After the interval t2 has expired, the output relay switches into off-position (yellow LED not illuminated). If the control contact S is opened before the interval t1 has expired, the interval already expired is erased and is restarted with the next cycle.

EI1 - Input delay pulse limitation timer voltage control

When the supply voltage U is applied, the set interval t1 begins (green LED U/t flashes slowly). After the interval t1 has

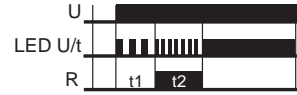

expired, the output relay switches into on-position (yellow LED illuminated) and the set interval t2 begins (green LED U/t flashes fast). After the interval t2 has expired, the output relay switches into off-position (yellow LED not illuminated). If the supply voltage is interrupted before the interval t1+t2 has expired, the interval already expired is erased and is restarted when the supply voltage is next applied.

EI3 - Input delay pulse limitation timer with control contact

The supply voltage U must be constantly applied to the device (green LED U/t illuminated). When the control contact S is closed, the set interval t1 begins (green LED U/t flashes slow-

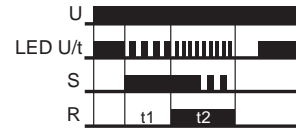

ly). After the interval t1 has expired, the output relay switches into on-position (yellow LED illuminated) and the set interval t2 begins (green LED U/t flashes fast). After the interval t2 has expired, the output relay switches into off-position (yellow LED not illuminated). During the interval, the control contact can be operated any number of times. A further cycle can only be started when the cycle run has been completed.

EI2 - Input delay pulse with control contact

The supply voltage U must be constantly applied to the device (green LED U/t illuminated). When the control contact S is closed, the output relay R switches into on-position (yellow

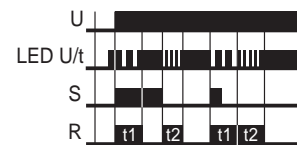

LED illuminated) and the set interval t1 begins (green LED U/t flashes slowly). After the interval t1 has expired, the output relay switches into off-position (yellow LED not illuminated). When the control contact is opened, the output relay switches into on-position again (yellow LED illuminated) and the set interval t2 begins (green LED U/t flashes fast). After the interval t2 has expired, the output relay switches into off-position again. During the interval, the control contact can be operated any number of times.

Multifunction clock-pulse generator relay

MFT ITU24S

I3 - Pulse detection

When the supply voltage U is applied, the set interval t1 begins (green LED U/t flashes slowly) and the output relay R switches into on-position (yellow LED illuminated). After the interval t1 has expired, the set interval t2 begins

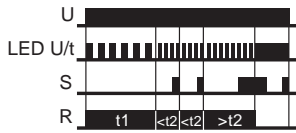

(green LED U/t flashes fast). For the output relay to remain in on-position, the control contact S must be closed and reopened within the set interval t2. If this does not occur, the output relay R switches into off-position (yellow LED not illuminated) and all further pulses at the control contact S are ignored. To restart the function, the supply voltage must be interrupted and reapplied.

Connection

MFT ITU24S

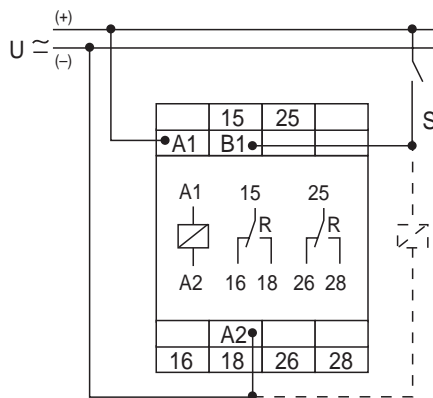

Load limit curves

MFT ITU24S

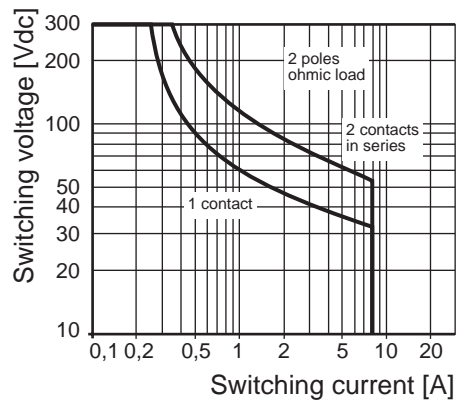

Dimensions

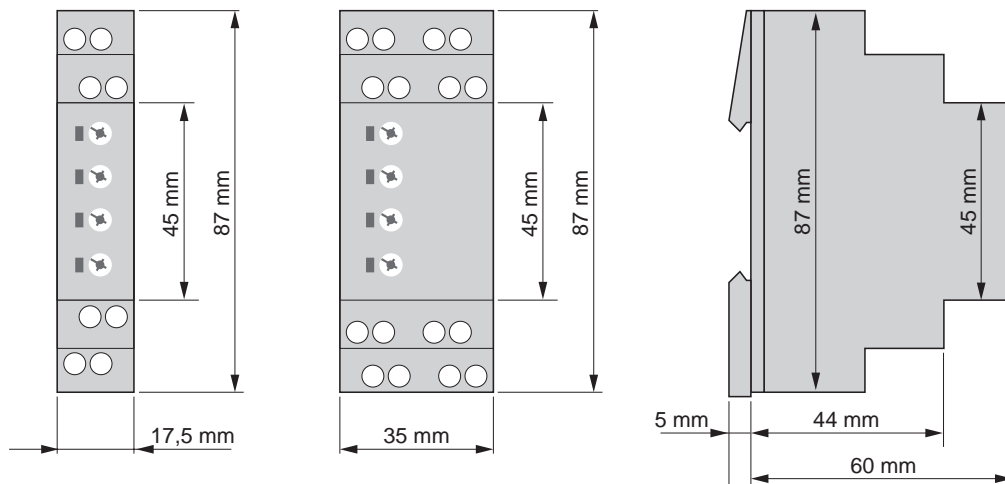

Technical safety advice

This manual contains the information necessary for the correct utilisation of the products described therein. It is intended for technically qualified persons who are involved as either

- planning engineers familiar with the safety concepts of automation technology;
- or, operating personnel, who have been instructed in handling automation equipment and have a knowledge of the contents of this manual concerning operation;
- or, installation and servicing personnel possessing the necessary training to repair such an automation system or who have the authority to put such circuits and equipment/systems into operation, to earth or label them according to the relevant safety standards.

The products are constructed, manufactured and tested in compliance with the relevant VDE standards, VDE specifications and IEC recommendations.

Danger warning

These warnings serve both as a guide for those persons involved in a project and as safety advice to prevent damage to the products themselves or to associated equipment.

Due to advancements in technology, the wiring diagram on the actual device may be different than shown in this catalogue. In all instances where the actual device diagram is different, the wiring diagram on the device must be used when electrical connections are made.

Correct utilisation, configuration and assembly

The equipment is to be used only for the applications stated in the catalogue and technical literature, and only in conjunction with auxiliary equipment and devices that are recommended or approved by Selectron Systems Ltd.

Further, it should be noted that:

- the automation equipment must be disconnected from any power supply before it is assembled, disassembled or the configuration modified.
- Solid state electronic switches must not be tested with incandescent lamps or connected to a load that exceeds its rating.
- trouble-free and safe operation of the products requires correct transportation as well as appropriate storage, assembly and wiring.

- the systems may only be installed by trained personnel. In doing so, the relevant requirements contained in VDE 0100, VDE 0113, IEC 364, etc. must be complied with.

Prevention of material damage or personal injury

Additional external safety devices or facilities must be provided wherever significant material damage or even personal injury could result from a fault occurring in an automation system. A defined operating status must be ensured or forced by such devices or facilities (e.g. by independent limit switches, mechanical interlocks, etc.).

Advice concerning planning and installation of the products

- The safety and accident prevention measures applicable to a specific application are to be observed.
- In the case of mains-operated equipment, a check is to be made before putting it into operation to ensure that the preset mains voltage range is suitable for the local supply.
- In the case of a 24 V supply, care must be taken to ensure sufficient electrical insulation of the secondary side. Use only mains power supply units that conform to IEC 364-4-41 or HD 384.04.41 (VDE 0100 Part 410).
- Automation systems and their operating elements are to be installed in such a way that they are sufficiently protected against accidental operation.

Warranty

Selectron Systems Ltd. warrants its products to be free from defects in material and workmanship for a period of one year from the date of shipment. All claims under this warranty must be made within thirty (30) days of the discovery of the defect, and all defective products must be returned at the buyer's expense. Buyer's sole and exclusive right will be limited to, at the option of Selectron Systems Ltd., the repair or replacement by Selectron Systems Ltd., of any defective products for which a claim is made.

In all other matters please refer to the „General terms of business“ concerning Selectron Systems Ltd.

Note

The information given in this documentation corresponds to the state of development at the time of going to press and is therefore not binding. Selectron Systems Ltd. reserves the right to make alterations in the interests of technical advancement or product improvement at any time without giving reasons for doing so.

Prescriptions and standards

Mechanical data	
Housings in self-extinguishing plastic material. Protection mode IP 40	
Fixing on profile rail TS 35 according to EN 50 022	
Connection mark according to IEC67-1-18a	
Environmental conditions	
Admissible environmental temperatures from -25 °C ... +55 °C (corresponds IEC 68-1)	
Storage and transport temperature from -25 °C ... +70 °C	
Relative humidity 15% to 85% (according to IEC 721-3-3 class 3K3)	
Pollution degree 2, if built-in 3 (according to IEC 664-1)	
Vibration resistance 10 to 55 Hz 0,35 mm (according to IEC 68-2-6)	
Shock resistance 15 g 11 ms (according to IEC 68-2-27)	
Output relay	
Electrical lifetime:	2 x 10 ⁶ switching cycles at 1000 VA ohmic load
Mechanical lifetime:	20 x 10 ⁶ switching cycles
Contact material	AgNi 0,15
Supply voltage	
Frequency range	48 ... 63 Hz
Duty cycle	100%, IEC class 1c
Protection	
Protection of the unit	8 A fast
Terminals	
Contact protection according VDE 0106 and VBG 4	
Terminal arrangement and connecting mark according DIN 46 199	
Terminal type:	Terminal connection according to VBG 4 (PZ1 required)
Terminal variants:	1 wire 0,5 mm ² ... 2,5 mm ² with/without wire end covers
	1 wire 4 mm ² without wire end covers
	2 wires 0,5 mm ² ... 1,5 mm ² with/without wire end covers
	2 wires 2,5 mm ² flexible without wire end covers
max. screw in torque:	1,0 Nm
Insulation	
Overvoltage category	III (according to IEC 60664-1)
Rating surge voltage:	4 kV
Electromagnetic compatibility	
Electrostatic discharge:	6 kV contact, 8 kV air (corresponds to IEC 61000-4-2)
High frequency electromagnetic fields:	Level 3, 10 V/m (corresponds to IEC 61000-4-3)
Fast transients:	4 kV / 5 kHz, 5/50 ns (corresponds to IEC 61000-4-4)
Lightning discharge:	2 kV com., 1 kV dif., (corresponds to IEC 61000-4-5)
Cable running disturbances induced by HF fields:	Level 3, 10 V RMS (corresponds to IEC 71000-4-6)
Spurious radiation net and aerial network:	Class B (corresponds to EN 55011)
Prescriptions	
Air and leakage paces:	EN 61812-1 (see Insulation)
Test voltage:	EN 61812-1 (see Insulation)
Low voltage directions according to EN 61812-1 (see Insulation)	
EMC emissions:	IEC 61000-6-4
EMC interference stability:	IEC 61000-6-2
Burst:	4 kV / 5 kHz, 5/50 ns (corresponds to IEC 61000-4-4)
ESD:	6 kV contact, 8 kV air (corresponds to IEC 61000-4-2)
Production standard:	according to ISO 9001
Basic standards:	IEC 61000-6-4, IEC 61000-4-2

Timer delay relays

Content

Multifunctional time delay relay industrial design

Star-delta relay	
MFT DS22A	2
Technical data.....	3
Function descriptions.....	4
Accessories	5
Protection cover.....	5
Mounting plate.....	5
Technical safety advice	6
Prescriptions and standards.....	7

Edition 02.08

Subject to technical changes and amendments to
technical specifications at any time

Star-delta relay

MFT DS22A



MFT DS22A

- **Star-delta start-up**
- **Multivoltage:**
24 ... 240 Vac/dc
- **2 changers**

Functions

Star-Delta start-up.

Time range

Star times 500 ms ... 3 min.

Transit times 40 ms, 60 ms, 80 ms, 100 ms

Output relay

2 potential free change-over contacts

Rated voltage: 250 Vac

- Switching capacity (distance <5 mm): 750 VA (3 A / 250 Vac)

- Switching capacity (distance >5 mm): 1250 VA (5 A / 250 Vac)

Fusing: 5A fast acting

Indicators

Green LED ON: indication of supply voltage
delta-contactor in on-position

Green LED flashes: indication of star-time

Yellow LED ON/OFF: indication of star-contactor

Connecting voltage

24 ... 240 Vdc, -20% ... +25%

24 ... 240 Vac, -15% ... +10%

100% duration of operation

Reference data

Selectron® MFT	Article no.
DS22A 24 ... 240 Vac/dc	41230007
(Order data see chapter 1)	

Star-delta relay

MFT DS22A

Technical data	
Nominal consumption	
	4.5 VA / 1 W
Accuracy	
	Scale limit stops $\pm 0,5\%$
	Repeatability of the scale limit
at constant conditions	± 5 ms or $< 0,5\%$
Adjustment accuracy	$\leq 5\%$
Temperature influence	$\leq 0,01\%$ / °C

Type key

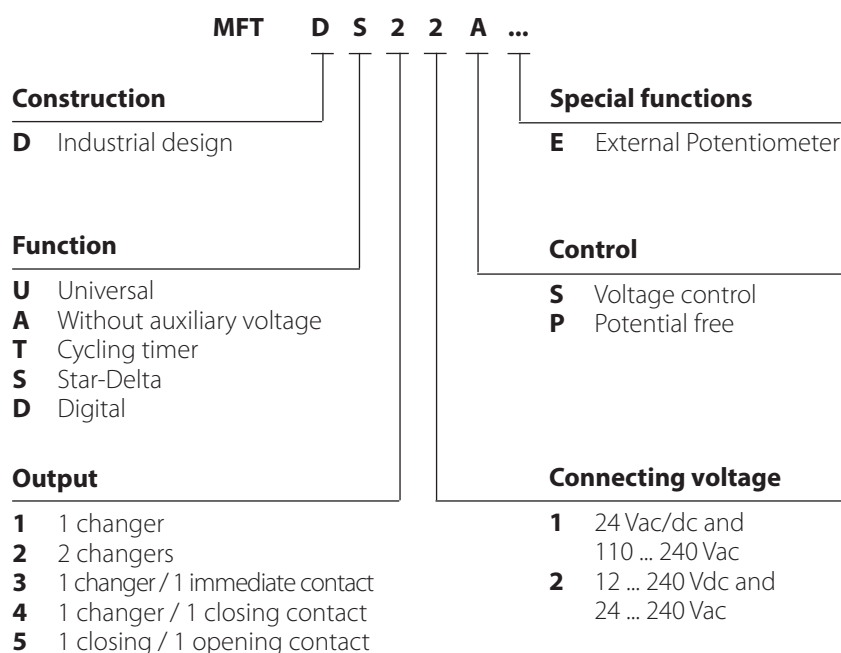

Star-delta relay

MFT DS22A

Function descriptions

Star-delta start-up (S)

When the supply voltage U is applied, the star-contact switches into on-position (yellow LED illuminated) and the set star-time t_1 begins (green LED flashing). After the interval t_1 has expired (green LED illuminated) the star-contact switches into off-position (yellow LED not illuminated) and the set transit-time t_2 begins. After the interval t_2 has expired the delta-contact switches into on-position.

To restart the function the supply voltage must be interrupted and re-applied..



Connection

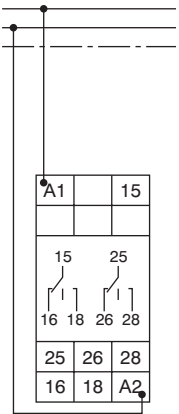

Dimensions

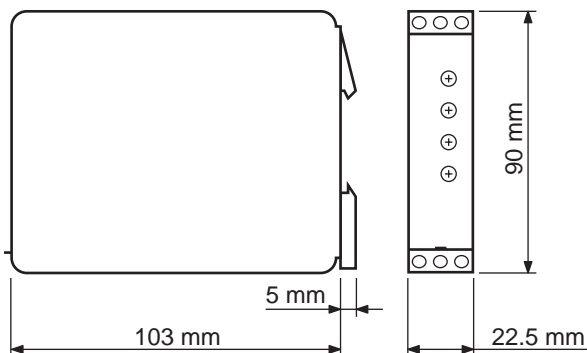

Protection cover

Protection cover of self-extinguishing plastic material with spring catch to seal with lead for all devices of the EMR series for protection of inadvertent or unauthorized changes of setup parameters.

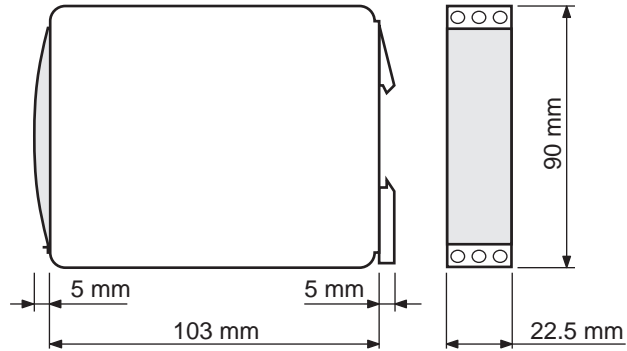

Description	Type	Weight	Article no
Protection cover for EMR (Order data see chapter 1)	SA 1	5 g	41230102

Mounting plate

The mounting-plate is used for the attachment of a DIN rail device on a mounting plate. Attachment by means of screws with 4 mm diameter.

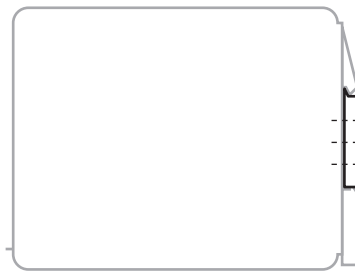

Description	Type	Weight	Article no
Mounting plate for EMR (Order data see chapter 1)	MP-1	5 g	41230101

Technical safety advice

This manual contains the information necessary for the correct utilisation of the products described therein. It is intended for technically qualified persons who are involved as either

- planning engineers familiar with the safety concepts of automation technology;
- or, operating personnel, who have been instructed in handling automation equipment and have a knowledge of the contents of this manual concerning operation;
- or, installation and servicing personnel possessing the necessary training to repair such an automation system or who have the authority to put such circuits and equipment/systems into operation, to earth or label them according to the relevant safety standards.

The products are constructed, manufactured and tested in compliance with the relevant VDE standards, VDE specifications and IEC recommendations.

Danger warning

These warnings serve both as a guide for those persons involved in a project and as safety advice to prevent damage to the products themselves or to associated equipment.

Due to advancements in technology, the wiring diagram on the actual device may be different than shown in this catalogue. In all instances where the actual device diagram is different, the wiring diagram on the device must be used when electrical connections are made.

Correct utilisation, configuration and assembly

The equipment is to be used only for the applications stated in the catalogue and technical literature, and only in conjunction with auxiliary equipment and devices that are recommended or approved by Selectron Systems Ltd.

Further, it should be noted that:

- the automation equipment must be disconnected from any power supply before it is assembled, disassembled or the configuration modified.
- Solid state electronic switches must not be tested with incandescent lamps or connected to a load that exceeds its rating.
- trouble-free and safe operation of the products requires correct transportation as well as

appropriate storage, assembly and wiring.

- the systems may only be installed by trained personnel. In doing so, the relevant requirements contained in VDE 0100, VDE 0113, IEC 364, etc. must be complied with.

Prevention of material damage or personal injury

Additional external safety devices or facilities must be provided wherever significant material damage or even personal injury could result from a fault occurring in an automation system. A defined operating status must be ensured or forced by such devices or facilities (e.g. by independent limit switches, mechanical interlocks, etc.).

Advice concerning planning and installation of the products

- The safety and accident prevention measures applicable to a specific application are to be observed.
- In the case of mains-operated equipment, a check is to be made before putting it into operation to ensure that the preset mains voltage range is suitable for the local supply.
- In the case of a 24 V supply, care must be taken to ensure sufficient electrical insulation of the secondary side. Use only mains power supply units that conform to IEC 364-4-41 or HD 384.04.41 (VDE 0100 Part 410).
- Automation systems and their operating elements are to be installed in such a way that they are sufficiently protected against accidental operation.

Warranty

Selectron Systems Ltd. warrants its products to be free from defects in material and workmanship for a period of one year from the date of shipment. All claims under this warranty must be made within thirty (30) days of the discovery of the defect, and all defective products must be returned at the buyer's expense. Buyer's sole and exclusive right will be limited to, at the option of Selectron Systems Ltd., the repair or replacement by Selectron Systems Ltd., of any defective products for which a claim is made.

In all other matters please refer to the „General terms of business“ concerning Selectron Systems Ltd.

Note

The information given in this documentation corresponds to the state of development at the time of going to press and is therefore not binding. Selectron Systems Ltd. reserves the right to make alterations in the interests of technical advancement or product improvement at any time without giving reasons for doing so.

Prescriptions and standards

Mechanical data

Housings in self-extinguishing plastic material. Protection mode IP 40

Mounting: snapping mode: Fixing on profile rail according DIN 46277/3 (EN 50 022)

Connection via contact protected terminals up to 4 mm², protecting mode IP 20

Environmental conditions

Admissible environmental temperatures from -25 °C ... +55 °C (corresponds IEC 68-1)

Storage and transport temperature from -25 °C ... +70 °C

Application class IEC 721-3-3 c(EN 60721-3-3)

Output relay

Electrical lifetime: 250 Vac, min. 2x10⁵ switching cycles at 1000 VA ohmic load.

Mechanical lifetime: min. 20 x 10⁶ switching cycles

Contact material AgNi

Connecting voltage

Frequency range 48 ... 400 Hz / 24 ... 240 Vac, 16 ... 48 Hz / 24 ... 48 Vac

Duration of operation 100%

Protection

Protection of the unit 5 A fast

Terminals

Contact protection according VDE 0106 and VBG 4

Terminal type: sleeve with indirect screw pressure

Wire to connect: rigid or flexible

Connecting limit: 4 mm²

Terminal variants: 1 wire 0,5 mm² ... 2,5 mm² with/without wire end covers

1 wire 4 mm² without wire end covers

2 wires 0,5 mm²... 1,5 mm² with/without wire end covers

2 wires 2,5 mm² flexible without wire end covers

max. screw in torque: 1,0 Nm

Terminal screw for screw driver with PZ-1

Insulation

Isolation nominal voltage: 250 Vac (corresponds to IEC 60664-1)

Rating surge voltage: 4 kV, over-voltage category III, corresponds to IEC 60664-1

Electromagnetic compatibility

Electrostatic discharge: Level 3, 6 kV contact, 8 kV air (corresponds to IEC 1000-4-2)

High frequency electromagnetic fields: Level 3, 10 V/m (corresponds to IEC 1000-4-3)

Fast transients: Level 4, 4 kV / 2,5 kHz, 5/50 ns (corresponds to IEC 1000-4-4)

Lightning discharge: Level 3, 2 kV com., 1 kV dif., (corresponds to IEC 1000-4-5)

Cable running disturbances inducted by HF fields: Level 3, 10 V RMS (corresponds to IEC 1000-4-6)

Spurious radiation net and aerial network: Class B (corresponds to CISPR 22)

Prescriptions

Air and leakage paces: VDE 01 10iGr. C/250

Test voltage: VDE 0435 2000Vac

Low voltage directions according to IEC 664-1

EMC emissions: EN 50 081-1 and EN 55 022 class B

EMC interference stability: Voltage impact strength according to IEC 1000-4-5

Burst: EN 50 082-2, EN 61 812-1 (level 3)

ESD: IEC 1000-4-2

HF over metallic circuits: EN 50 082-2, ENPr 50141

Electro magnetic HF field according to EN 50 082-2, ENPr 50140 and ENPr 50204

Production standard: according to ISO 9001

Monitoring Relays

Content

Monitoring Relays Pluggable

1-phase current monitoring relay	
EMR SI23O, SI23P	2
Technical data.....	3
Function description	4
Connection	5
1-phase direct-current voltage monitoring relay	
EMR SU21I, SU21J, SU21K, SU21L	6
Technical data.....	7
Connection	8
Function description	8
1-phase voltage monitoring relay	
EMR SU21M, SU21N.....	10
Technical data.....	11
Connection	12
Function description	12
3-phase voltage monitoring relay	
EMR SU31D.....	14
Technical data.....	15
Connection	16
Function description.....	16
3-phase voltage monitoring relay (Multifunction)	
EMR SU31C1, SU31D1	18
Technical data.....	19
Function description	20
Connection	21
Accessories monitoring relays.....	22
Plug in socket	22
Technical safety advice	23
Prescriptions and standards.....	24

Edition 02.09

Subject to technical changes and amendments to technical specifications at any time

1-phase current monitoring relay

EMR SI230, SI23P



EMR SI230



EMR SI23P

- ac current monitoring in 1-phase mains
- Measuring range 1A / 5A ac
- Multifunction
- Error Memory (Latch)
- 2 change-over contacts

Functions

ac current monitoring in 1-phase mains with adjustable thresholds, timing for start-up suppression and tripping delay separately adjustable and the following functions (selectable by means of rotary switch)

- Overcurrent monitoring
- Overcurrent monitoring with error memory
- Undercurrent monitoring
- Undercurrent monitoring with error memory
- Monitoring the window between Min and Max
- Monitoring the window between Min and Max with error memory

Time ranges

Start-up suppression time: Adjustment range 0 ... 10 s
 Tripping delay: Adjustment range 0.1 ... 10 s

Indicators

Green LED ON: indication of supply voltage
 Green LED flashing: indication of start-up suppression time
 Yellow LED ON/OFF: indication of relay output
 Red LED ON/OFF: indication of failure of the corresponding threshold
 Red LED flashing: indication of tripping delay of the corresponding threshold

Output relay

2 potential free change-over contacts
 Rated voltage: 250 Vac
 Switching capacity: 1250 VA (5 A / 250 Vac)
 Fusing: 5A fast acting

Connecting voltages

230 Vac, -15% ... +10% (galvanically separated)
 100% duration of operation

Reference data

Selectron® EMR	Article no.
EMR SI230 1A	41230015
EMR SI23 P 5A	41230016
(Order data see chapter 1)	

1-phase current monitoring relay

EMR SI230, SI23P

Technical data	
Nominal consumption	8 VA / 1 W
Nominal frequency	48 ... 63 Hz
Wave form ac	sine
Drop-out voltage	>20% of the supply voltage
Base accuracy	±5% (of maximum nominal value)
Adjustment accuracy	≤5% (of maximum nominal value)
Repetition accuracy	≤2%
Temperature influence	≤0.1% / °C
Frequency response	-
Recovery time	500 ms
Measuring circuit: Input:	
1 A / 5 A ac	terminals 6 (21) and 7 (24)
Overload capacity:	
1 A ac	10 A
5 A ac	10 A
Input resistance:	
1 A ac	< 10 mΩ
5 A ac	< 10 mΩ
Switching threshold:	
Max:	10% ... 100% of I_N
Min:	5% ... 95% of I_N

Type key

EMR		S	I	2	3	O	...		
Construction				Special functions					
D Industrial design 22.5 mm S pluggable 11 poles				1 = Additional asymmetry monitoring					
Function				Measuring circuit					
U Voltage I Current P CosPhi T Temperature S Star-Delta				A No measuring circuit B 3(N)~115/66 Vac C 3(N)~230/132 Vac D 3(N)~400/230 Vac E 1 ≅ 30/60/300 Vac/dc F 1 ≅ 100mA/1A/10A ac/dc G PTC H CosPhi				I 12 Vdc J 24 Vdc K 36 Vdc L 48 Vdc M 1~110 Vac N 1~230 Vac O 1 A P 5 A	
Output				Connecting voltage					
1 1 changer 2 2 changers 3 1 NC contact / 1 NO contact				1 Measuring circuit 2 24...240 Vac/dc 3 230 Vac					

1-phase current monitoring relay

EMR SI230, SI23P

Function description

When the supply voltage U is applied, the output relays switch into on-position (yellow LED illuminated) and the set interval of the start-up suppression (START) begins (green LED U flashes). Changes of the measured current during this period do not affect the state of the output relay. After the interval has expired the green LED is illuminated steadily.

For all the functions the LEDs MIN and MAX are flashing alternating, when the minimum value for the measured current was chosen to be greater than the maximum value.

Overcurrent monitoring (OVER, OVER+LATCH)

When the measured current exceeds the value adjusted at the MAX-regulator, the set interval of the tripping delay (DELAY) begins (red LED MAX flashes). After the interval has expired (red LED MAX illuminated), the output relays switch into off-position (yellow LED not illuminated). The output relays again switch into on-position (yellow LED illuminated), when the measured current falls below the value adjusted at the MIN-regulator (red LED MAX not illuminated).

If the error memory is activated (OVER+LATCH) and the measured current remains above the MAX-value longer than the set interval of the tripping delay, the output relays remain in the off-position even if the measured current falls below the value adjusted at the MIN-regulator. After resetting the failure (interrupting and re-applying the supply voltage), the output relays switch into on-position and a new measuring cycle begins with the set interval of the start-up suppression (START).

Undercurrent monitoring (UNDER, UNDER+LATCH)

When the measured current falls below the value adjusted at the MIN-regulator, the set interval of the tripping delay (DELAY) begins (red LED MIN flashes). After the interval has expired (red LED MIN illuminated), the output relays switch into off-position (yellow LED not illuminated). The output relays again switch into on-position (yellow LED illuminated), when the measured current exceeds the value adjusted at the MAX-regulator.

If the error memory is activated (UNDER+LATCH) and the measured current remains below the MIN-value longer than the set interval of the tripping delay, the output relays remain in the off-position even if the measured current exceeds the value adjusted at the MAX-regulator. After resetting the failure (interrupting and re-applying the supply voltage), the output relays switch into on-position and a new measuring cycle begins with the set interval of the start-up suppression (START).

Window function (WIN, WIN+LATCH)

The output relays switch into on-position (yellow LED illuminated) when the measured current exceeds the value adjusted at the MIN-regulator. When the measured current exceeds the value adjusted at the MAX-regulator, the set interval of the tripping delay (DELAY) begins (red LED MAX flashes). After the interval has expired (red LED MAX illuminated), the output relays switch into off-position (yellow LED not illuminated). The output relays again switch into on-position (yellow LED illuminated) when the measured current falls below the value adjusted at the MAX-regulator (red LED MAX not illuminated). When the measured current falls below the value adjusted at the MIN-regulator, the set interval of the tripping delay

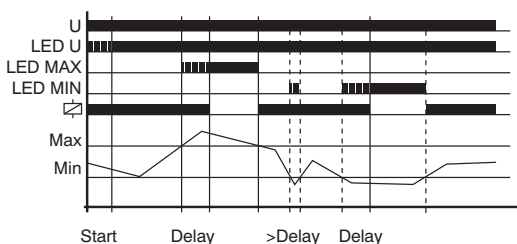
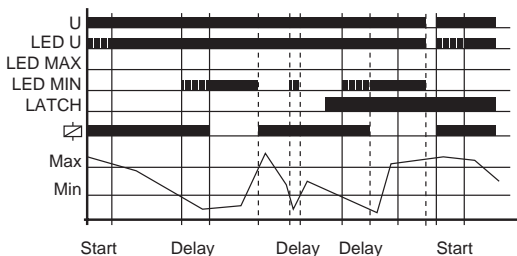
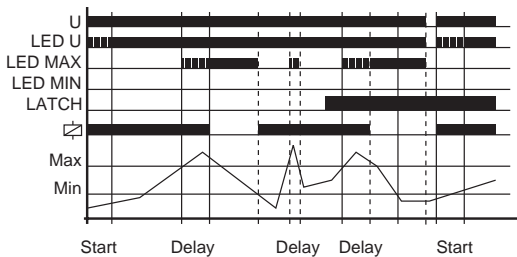

1-phase current monitoring relay

EMR SI230, SI23P

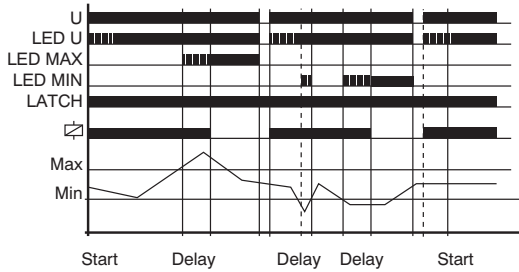

(DELAY) begins again (red LED MIN flashes). After the interval has expired (red LED MIN illuminated), the output relays switch into off-position (yellow LED not illuminated).

If the error memory is activated (WIN+LATCH) and the measured current remains below the MIN-value longer than the set interval of the tripping delay, the output relays remain in the off-position even if the measured current exceeds the value adjusted at the MIN-regulator. If the measured current remains above the MAX-value longer than the set interval of the tripping delay, the output relays remain in the off-position even if the measured current falls below the value adjusted at the MAX-regulator. After resetting the failure (interrupting and re-applying the supply voltage), the output relays switch into on-position and a new measuring cycle begins with the set interval of the start-up suppression (START).

Connection

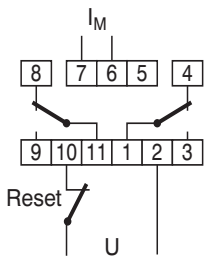

With error memory
Measuring range 11 A or 5 A
U = supply voltage 230 Vac

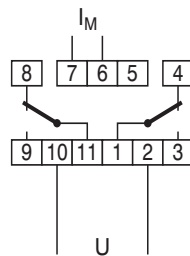

Without error memory
Measuring range 1 A or 5 A
U = supply voltage 230 Vac

Dimensions

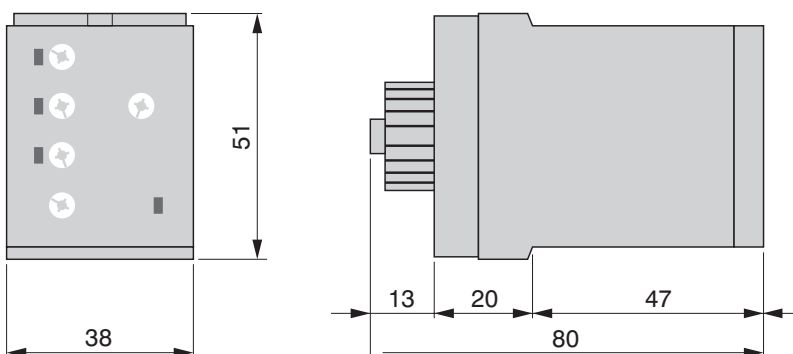

1-phase direct-current voltage monitoring relay

EMR SU21I, SU21J, SU21K, SU21L



EMR SU21I



EMR SU21J



EMR SU21K



EMR SU21L

- dc voltage monitoring in 1-phase mains
- Measuring range 12/24/36/48 Vdc
- Multifunction
- 2 change-over contacts

Functions

dc voltage monitoring in 1-phase mains with adjustable thresholds, and the following functions (selectable by means of rotary switch)

- Undervoltage monitoring
- Monitoring the window between Min and Max

Indicators

Green LED ON:	indication of supply voltage
Yellow LED ON/OFF:	indication of relay output
Red LED ON/OFF:	indication of failure of the corresponding threshold

Output relay

2 potential free change-over contacts	
Rated voltage:	250 Vac
Switching capacity:	1250 VA (5 A / 250 Vac)
Fusing:	5A fast acting

Connecting voltages

12/24/36/48 Vdc (= Measuring voltage)
100% duration of operation

Reference data

Selectron® EMR	Article no.
SU21I	41230009
SU21J	41230010
SU21K	41230011
SU21L	41230012

(Order data see chapter 1)

1-phase direct-current voltage monitoring relay

EMR SU21I, SU21J, SU21K, SU21L

Technical data	
Nominal consumption	2 W
Ripple at dc	10%
Drop-out voltage	according to switching threshold
Base accuracy	±5% (of maximum nominal value)
Adjustment accuracy	±5% (of maximum nominal value)
Repetition accuracy	≤2% (of maximum nominal value)
Temperature influence	<0.1% / °C
Recovery time	500 ms
Measuring circuit: Measured variable	dc or ac sine (16.6 ... 400 Hz)
Input:	
12/24/36/48 Vdc	terminals 2 (A1) and 10 (A2)
Overload capacity:	
12/24/36/48 Vdc	-25% ... +30%
Input resistance:	
12/24/36/48 Vdc	according to nominal voltage 2 W
Switching threshold:	
Max:	80% ... 130% of U_N
Min:	75% ... 125% of U_N

Type key

EMR		S	U	2	1	I	...
Construction			Special functions				
D	Industrial design 22.5 mm		1 = Additional asymmetry monitoring				
S	pluggable 11 poles						
Function			Measuring circuit				
U	Voltage		A	No measuring circuit		I	12 Vdc
I	Current		B	3(N)~115/66 Vac		J	24 Vdc
P	CosPhi		C	3(N)~230/132 Vac		K	36 Vdc
T	Temperature		D	3(N)~400/230 Vac		L	48 Vdc
S	Star-Delta		E	1 ≅ 30/60/300 Vac/dc		M	1~110 Vac
			F	1 ≅ 100mA/1A/10A ac/dc		N	1~230 Vac
			G	PTC		O	1 A
			H	CosPhi		P	5 A
Output			Connecting voltage				
1	1 changer		1	Measuring circuit			
2	2 changers		2	24...240 Vac/dc			
3	1 NC contact / 1 NO contact		3	230 Vac			

1-phase direct-current voltage monitoring relay

EMR SU21I, SU21J, SU21K, SU21L

Function description

For all the functions the LEDs MIN and MAX are flashing alternating, when the minimum value for the measured voltage was chosen to be greater than the maximum value.

If a failure already exists when the device is activated, the output relays remain in off-position and the LED for the corresponding threshold is illuminated.

Under voltage monitoring (UNDER)

When the measured voltage falls below the value adjusted at the MIN-regulator, the output relays switch into off-position (yellow LED not illuminated). The output relays again switch into on-position (yellow LED illuminated), when the measured voltage exceeds the value adjusted at the MAX-regulator.

Window function (WIN)

The output relays switch into on-position (yellow LED illuminated) when the measured voltage exceeds the value adjusted at the MIN-regulator. When the measured voltage exceeds the value adjusted at the MAX-regulator, the output relays switch into off-position (yellow LED not illuminated). The output relays again switch into on-position (yellow LED illuminated) when the measured voltage falls below the value adjusted at the MAX-regulator (red LED MAX not illuminated). When the measured voltage falls below the value adjusted at the MIN-regulator, the output relays switch into off-position (yellow LED not illuminated).

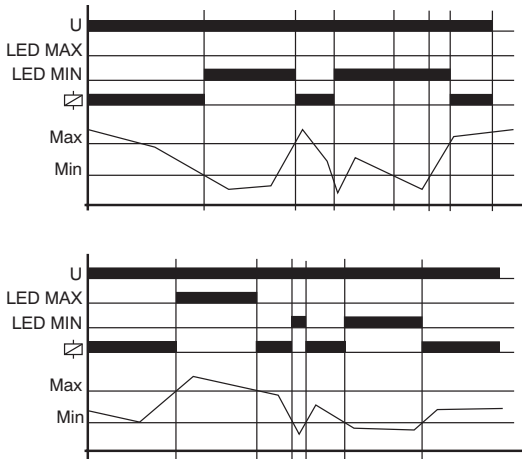

Connection

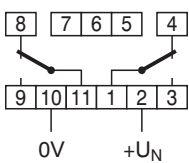

Measuring range 12, 24, 36 or 48 Vdc
Supply voltage = measuring range

Dimensions

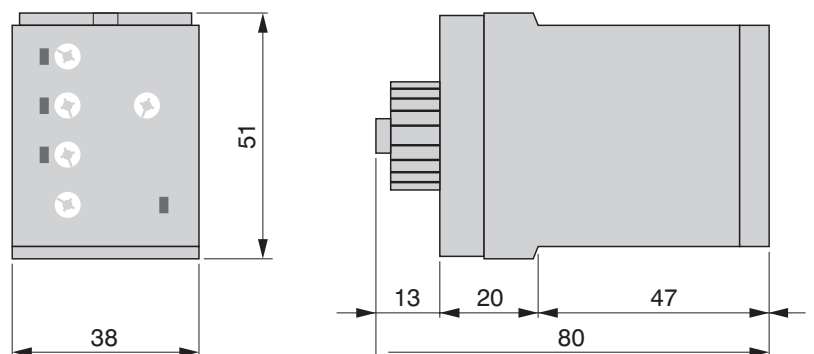

1-phase voltage monitoring relay

EMR SU21M, SU21N



EMR SU21M



EMR SU21N

- ac voltage monitoring in 1-phase mains
- Measuring range 110/230 Vac
- Multifunction
- 2 change-over contacts

Functions

ac voltage monitoring in 1-phase mains with adjustable thresholds, and the following functions (selectable by means of rotary switch)

- Undervoltage monitoring
- Monitoring the window between Min and Max

Indicators

- Green LED ON: indication of supply voltage
- Yellow LED ON/OFF: indication of relay output
- Red LED ON/OFF: indication of failure of the corresponding threshold

Output relay

- 2 potential free change-over contacts
- Rated voltage: 250 Vac
- Switching capacity: 1250 VA (5 A / 250 Vac)
- Fusing: 5A fast acting

Connecting voltages

- 110/230 Vac (= Measuring voltage)
- 100% duration of operation

Reference data

Selectron® EMR	Article no.
SU21M 110 Vac	41230013
SU21N 230 Vac	41230014

(Order data see chapter 1)

1-phase voltage monitoring relay

EMR SU21M, SU21N

Technical data	
Nominal consumption	110 V, 4 VA (1 W)
	230 V, 8 VA (1 W)
Nominal frequency	48 ... 63 Hz
Drop-out voltage	according to switching threshold
Base accuracy	±5% (of maximum nominal value)
Adjustment accuracy	±5% (of maximum nominal value)
Repetition accuracy	≤2% (of maximum nominal value)
Temperature influence	<0.1% / °C
Recovery time	500 ms
Measuring circuit: Measured variable	ac sine (48 ... 63 Hz)
Input:	
110/230 Vac	terminals 2 (A1) and 10 (A2)
Overload capacity:	
110/230 Vac	-30% ... +20%
Input resistance:	
110 Vac	according to nominal voltage 4 VA / 1 W
230 Vac	according to nominal voltage 8 VA / 1 W
Switching threshold:	
Max:	80% ... 120% of U_N
Min:	70% ... 110% of U_N

Type key

EMR		S	U	2	1	M	...
Construction			Special functions				
D Industrial design 22.5 mm S pluggable 11 poles			1 = Additional asymmetry monitoring				
Function			Measuring circuit				
U Voltage I Current P CosPhi T Temperature S Star-Delta			A No measuring circuit B 3(N)~115/66 Vac C 3(N)~230/132 Vac D 3(N)~400/230 Vac E 1 ≙ 30/60/300 Vac/dc F 1 ≙ 100mA/1A/10A ac/dc G PTC H CosPhi				
Output			Connecting voltage				
1 1 changer 2 2 changers 3 1 NC contact / 1 NO contact			1 Measuring circuit 2 24...240 Vac/dc 3 230 Vac				
			I 12 Vdc J 24 Vdc K 36 Vdc L 48 Vdc M 1~110 Vac N 1~230 Vac O 1 A P 5 A				

1-phase voltage monitoring relay

EMR SU21M, SU21N

Function description

For all the functions the LEDs MIN and MAX are flashing alternating, when the minimum value for the measured voltage was chosen to be greater than the maximum value.

If a failure already exists when the device is activated, the output relays remain in off-position and the LED for the corresponding threshold is illuminated.

Under voltage monitoring (UNDER)

When the measured voltage falls below the value adjusted at the MIN-regulator, the output relays switch into off-position (yellow LED not illuminated). The output relays again switch into on-position (yellow LED illuminated), when the measured voltage exceeds the value adjusted at the MAX-regulator.

Window function (WIN)

The output relays switch into on-position (yellow LED illuminated) when the measured voltage exceeds the value adjusted at the MIN-regulator. When the measured voltage exceeds the value adjusted at the MAX-regulator, the output relays switch into off-position (yellow LED not illuminated). The output relays again switch into on-position (yellow LED illuminated) when the measured voltage falls below the value adjusted at the MAX-regulator (red LED MAX not illuminated). When the measured voltage falls below the value adjusted at the MIN-regulator, the output relays switch into off-position (yellow LED not illuminated).

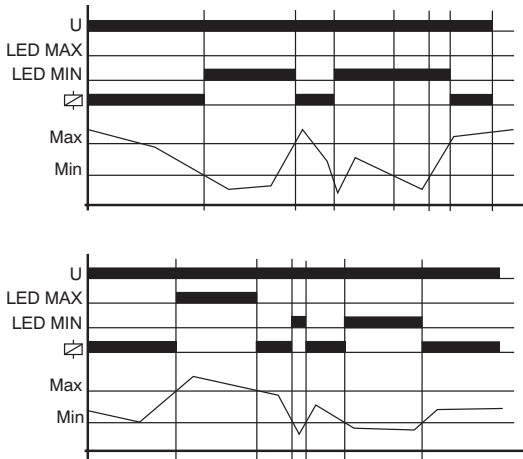

Connection

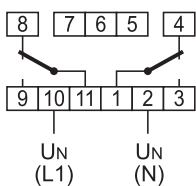

Measuring range 110 or 230 Vac
Supply voltage = measuring range

Dimensions

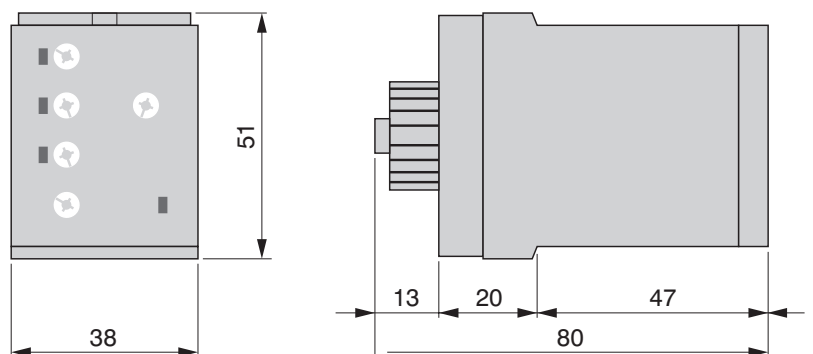

3-phase voltage monitoring relay

EMR SU31D



EMR SU31D

- Voltage monitoring in 3-phase mains
- Measuring range 400/230 Vac 3Ph
- Monitoring of phase sequence and phase failure
- Detection of reverse voltage
- Connection of neutral wire optional
- 1 NC contact / 1 NO contact

Functions

Monitoring of phase sequence, phase failure and detection of return voltage (by means of evaluating the asymmetry).

Indicators

Green LED ON: indication of supply voltage
Yellow LED ON/OFF: indication of relay output

Output relay

1 NC contact / 1 NO contact
Rated voltage: 250 Vac
Switching capacity: 1250 VA (5 A / 250 Vac)
Fusing: 5A fast acting

Connecting voltages

3(N) ~400/230 V, Terminals (N)-L1-L2-L3 (= supply voltage)
100% duration of operation

Reference data

Selectron® EMR	Article no.
SU31D 400/230 Vac 3Ph	41230019
(Order data see chapter 1)	

3-phase voltage monitoring relay

EMR SU31D

Technical data	
Nominal consumption	3(N) ~400/230 V, 9 VA / 2 W
Nominal frequency	48 ... 63 Hz
Drop-out voltage	>20% of the nominal voltage
Recovery time	500 ms
Measuring circuit: Input:	
3(N) ~400/230 V	terminals (N)-L1-L2-L3 (= supply voltage)
Overload capacity:	
3(N) ~400/230 V	-30% ... +30%
Input resistance:	
3(N) ~400/230 V	according to nominal voltage 9 VA / 2 W
Asymmetry:	fix circa 30%

Type key

EMR		S	U	3	1	D	...
Construction				Special functions			
D Industrial design 22.5 mm S pluggable 11 poles				1 = Additional asymmetry monitoring			
Function				Measuring circuit			
U Voltage I Current P CosPhi T Temperature S Star-Delta				A No measuring circuit B 3(N)~115/66 Vac C 3(N)~230/132 Vac D 3(N)~400/230 Vac E 1 ≅ 30/60/300 Vac/dc F 1 ≅ 100mA/1A/10A ac/dc G PTC H CosPhi			
Output				Connecting voltage			
1 1 changer 2 2 changers 3 1 NC contact / 1 NO contact				1 Measuring circuit 2 24...240 Vac/dc 3 230 Vac			
				I 12 Vdc J 24 Vdc K 36 Vdc L 48 Vdc M 1~110 Vac N 1~230 Vac O 1 A P 5 A			

3-phase voltage monitoring relay

EMR SU31D

Function description

Phase sequence monitoring

When all the phases are connected in the correct sequence and the measured asymmetry is less than the fixed value, the output relays switch into on-position (yellow LED illuminated). When the phase sequence changes, the output relays switch into off-position (yellow LED not illuminated).

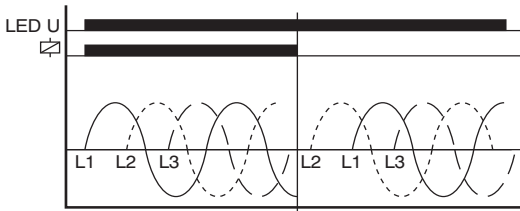

Phase failure monitoring

When one of the three phases fails, the output relays switch into off-position (yellow LED not illuminated).

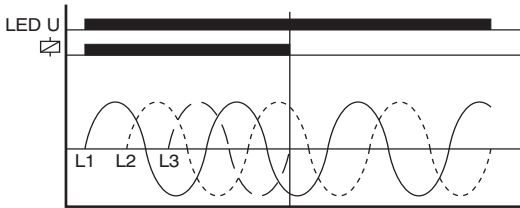

Detection of reverse voltage (by means of evaluation of asymmetry)

The output relays switch into off-position (yellow LED not illuminated) when the asymmetry between the phase voltages exceeds the fixed value of the asymmetry.

An asymmetry caused by the reverse voltage of a consumer (e.g. a motor which continues to run on two phases only) does not effect the disconnection.

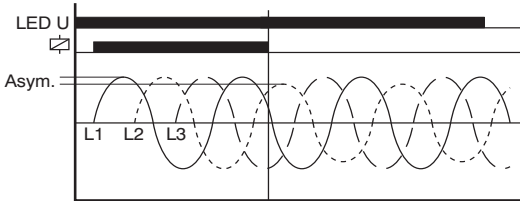

Connection

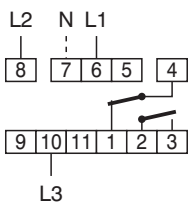

Measuring range 3 (N) 400/230 Vac
Supply voltage = measuring range

Dimensions

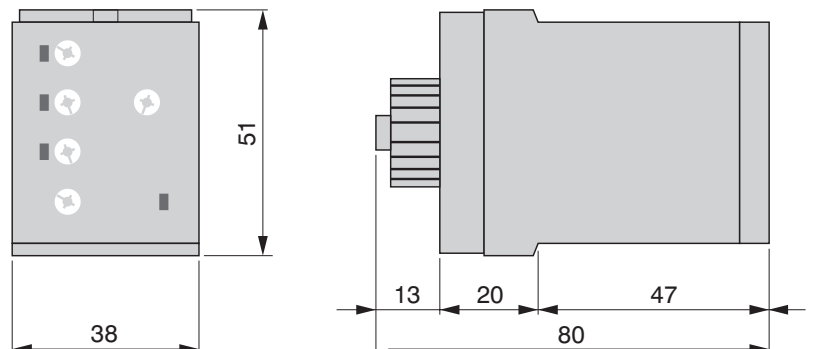

3-phase voltage monitoring relay (Multifunction)

EMR SU31C1, SU31D1



EMR SU31C1



EMR SU31D1

- **Voltage monitoring in 3-phase mains**
- **Measuring range 230/132 / 400/230 Vac 3Ph**
- **Multifunction**
- **Monitoring of phase sequence and phase failure**
- **Additional asymmetry monitoring**
- **Connection of neutral wire optional**
- **1 NC contact / 1 NO contact**

Functions

Voltage monitoring in 3-phase mains with adjustable thresholds, adjustable tripping delay, monitoring of phase sequence and phase failure, monitoring of asymmetry with adjustable threshold and the following functions (selectable by means of rotary switch)

- Undervoltage monitoring
- Undervoltage monitoring and monitoring of phase sequence
- Monitoring of window between Min and Max
- Monitoring the window between Min and Max and monitoring of phase sequence.

Time ranges

Start-up suppression time:-

Tripping delay:

Adjustment range 0.1 ... 10 s

Indicators

Red LED ON/OFF:

indication of failure of the corresponding threshold

Red LED flashes:

indication of tripping delay of the corresponding threshold

Yellow LED ON/OFF:

indication of relay output

Output relay

1 NC contact / 1 NO contact

Rated voltage: 250 Vac

Switching capacity: 1250 VA (5 A / 250 Vac)

Fusing: 5A fast acting

Connecting voltages

3 (N) ~ 230/132 V, terminals (N)_L1_L2_L3 (= Measuring voltage)

3 (N) ~ 400/230 V, terminals (N)_L1_L2_L3 (= Measuring voltage)

100% duration of operation

Reference data

Selectron® EMR	Article no.
SU31D1 400/230 Vac 3Ph	41230018
SU31C1 230/132 Vac 3Ph	41230017
(Order data see chapter 1)	

3-phase voltage monitoring relay (Multifunction)

EMR SU31C1, SU31D1

Technical data	
Nominal consumption	3(N) ~230/132 V, 6 VA (2 W)
	3(N) ~400/230 V, 9 VA (2 W)
Nominal frequency	48 ... 63 Hz
Drop-out voltage	>20% of the nominal voltage
Base accuracy	±5% (of maximum nominal value)
Adjustment accuracy	±5% (of maximum nominal value)
Repetition accuracy	≤2% (of maximum nominal value)
Temperature influence	≤0.1% / °C
Recovery time	500 ms
Measuring circuit: Measured variable	ac sine (48 ... 63 Hz)
Input:	
3(N) ~132/230 V	Terminals (N)-L1-L2-L3
3(N) ~230/400 V	Terminals (N)-L1-L2-L3
Overload capacity:	
3(N) ~132/230 V	-30% ... +30%
3(N) ~230/400 V	-30% ... +30%
Input resistance:	
3(N) ~132/230 V	according to nominal voltage 6 VA / 2 W
3(N) ~230/400 V	according to nominal voltage 9 VA / 2 W
Switching threshold:	
Max:	80% ... 130% of U_N
Min:	70% ... 120% of U_N
Asymmetry:	5% ... 30%

Type key

EMR S U 3 1 C 1	
Construction	Special functions
D Industrial design 22.5 mm	1 = Additional asymmetry monitoring
S pluggable 11 poles	
Function	Measuring circuit
U Voltage	A No measuring circuit
I Current	B 3(N)~115/66 Vac
P CosPhi	C 3(N)~230/132 Vac
T Temperature	D 3(N)~400/230 Vac
S Star-Delta	E 1 ≅ 30/60/300 Vac/dc
	F 1 ≅ 100mA/1A/10A ac/dc
	G PTC
	H CosPhi
Output	Connecting voltage
1 1 changer	1 Measuring circuit
2 2 changers	2 24...240 Vac/dc
3 1 NC contact / 1 NO contact	3 230 Vac
	I 12 Vdc
	J 24 Vdc
	K 36 Vdc
	L 48 Vdc
	M 1~110 Vac
	N 1~230 Vac
	O 1 A
	P 5 A

3-phase voltage monitoring relay (Multifunction) EMR SU31C1, SU31D1

Function description

For all the functions the LEDs MIN and MAX are flashing alternating, when the minimum value for the measured voltage was chosen to be greater than the maximum value.

If a failure already exists when the device is activated, the output relays remain in off-position and the LED for the corresponding threshold is illuminated.

Under voltage monitoring (UNDER, UNDER+SEQ)

When the measured voltage (one of the phase voltages) falls below the value adjusted at the MIN-regulator, the set interval of the tripping delay (DELAY) begins (red LED MIN flashes). After the interval has expired (red LED MIN illuminated), the output relays switch into off-position (yellow LED not illuminated). The output relays again switch into on-position (yellow LED illuminated), when the measured voltage exceeds the value adjusted at the MAX-regulator.

Window function (WIN, WIN+SEQ)

The output relays switch into on-position (yellow LED illuminated) when the measured voltage (one of the phase voltages) exceeds the value adjusted at the MIN-regulator. When the measured voltage exceeds the value adjusted at the MAX-regulator, the set interval of the tripping delay (DELAY) begins (red LED MAX flashes). After the interval has expired (red LED MAX illuminated), the output relays switch into off-position (yellow LED not illuminated). The output relays again switch into on-position (yellow LED illuminated) when the measured voltage falls below the value adjusted at the MAX-regulator (red LED MAX not illuminated). When the measured voltage falls below the value adjusted at the MIN-regulator, the set interval of the tripping delay (DELAY) begins again (red LED MIN flashes). After the interval has expired (red LED MIN illuminated), the output relays switch into off-position (yellow LED not illuminated).

Phase sequence monitoring (SEQ)

Phase sequence monitoring is selectable for all functions.

If a change in phase sequence is detected (red LED Asym./SEQ flashes), the output relays switch into off-position after the interval has expired (yellow LED not illuminated, red LED Asym./SEQ illuminated).

Phase failure monitoring (SEQ)

If one of the phase voltages fails, the set interval of the tripping delay (DELAY) begins (red LED SEQ flashes). After the interval has expired (red LED SEQ illuminated), the output relays switch into off-position (yellow LED not illuminated).

Reverse voltages of a consumer (e.g. a motor which continues to run on two phases only) do not effect the disconnection but can be monitored by using a proper value for the asymmetry.

Asymmetry monitoring

If the asymmetry between the phases exceeds the value set at the ASYM-regulator, the set interval of the tripping delay (DELAY) begins (red LED ASYM flashes). After the interval has expired (red LED ASYM illuminated), the output relays switch into off-position (yellow LED not illuminated).

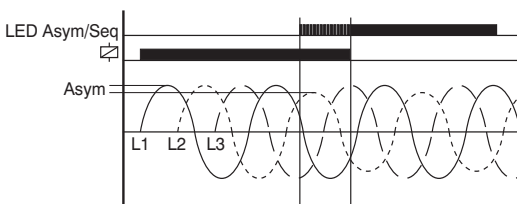
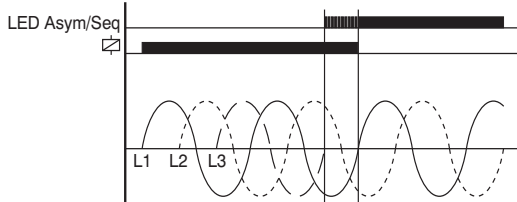
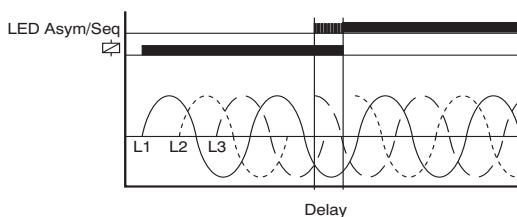
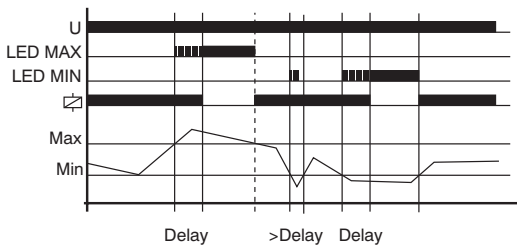
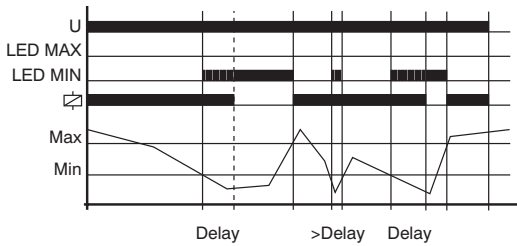

3-phase voltage monitoring relay (Multifunction) EMR SU31C1, SU31D1

Shift of the star-point (asymmetry) through unequal phase-load with missing neutral wire

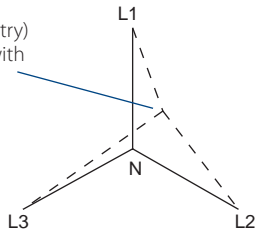

Loss of neutral wire by means of evaluation of asymmetry

A break of the neutral wire between power line and machinery is detected as soon as asymmetry between phase-to-phase voltage and neutral wire occurs. If the asymmetry exceeds the value set at the ASYM-regulator, the set interval of the tripping delay (DELAY) begins (red LED ASYM flashes). After the interval has expired (red LED ASYM illuminated), the output relays switch into off-position (yellow LED not illuminated). A break of the neutral wire between our device and the machinery can not be detected.

Connection

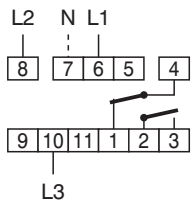

Measuring range 3 (N) 400/230 Vac
Supply voltage = measuring range

Dimensions

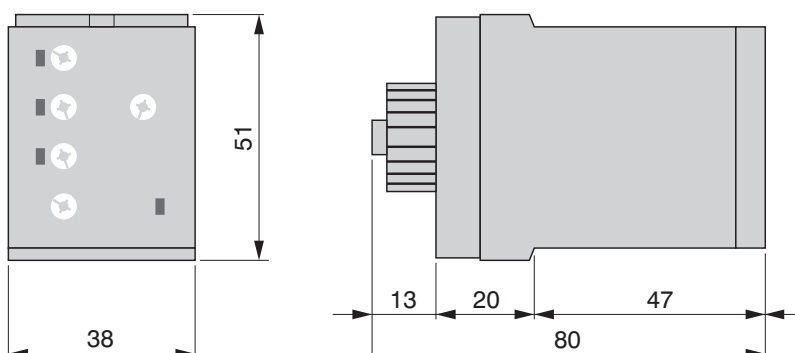

Accessories monitoring relays

Plug in socket

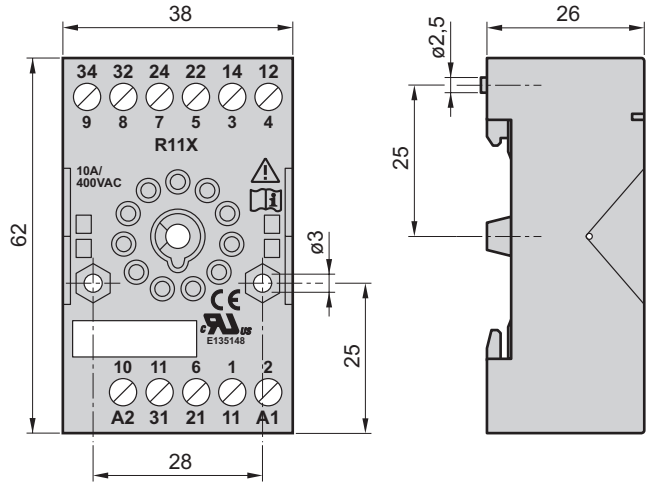
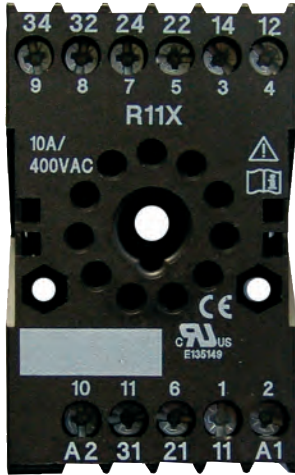

Description	Type	Article no.
Plug-in socket 11 poles (Order data see chapter 1)	SSK 11 N	41910006

Technical safety advice

This manual contains the information necessary for the correct utilisation of the products described therein. It is intended for technically qualified persons who are involved as either

- planning engineers familiar with the safety concepts of automation technology;
- or, operating personnel, who have been instructed in handling automation equipment and have a knowledge of the contents of this manual concerning operation;
- or, installation and servicing personnel possessing the necessary training to repair such an automation system or who have the authority to put such circuits and equipment/systems into operation, to earth or label them according to the relevant safety standards.

The products are constructed, manufactured and tested in compliance with the relevant VDE standards, VDE specifications and IEC recommendations.

Danger warning

These warnings serve both as a guide for those persons involved in a project and as safety advice to prevent damage to the products themselves or to associated equipment.

Due to advancements in technology, the wiring diagram on the actual device may be different than shown in this catalogue. In all instances where the actual device diagram is different, the wiring diagram on the device must be used when electrical connections are made.

Correct utilisation, configuration and assembly

The equipment is to be used only for the applications stated in the catalogue and technical literature, and only in conjunction with auxiliary equipment and devices that are recommended or approved by Selectron Systems Ltd.

Further, it should be noted that:

- the automation equipment must be disconnected from any power supply before it is assembled, disassembled or the configuration modified.
- Solid state electronic switches must not be tested with incandescent lamps or connected to a load that exceeds its rating.
- trouble-free and safe operation of the products requires correct transportation as well as appropriate storage, assembly and wiring.
- the systems may only be installed by trained personnel. In doing so, the relevant requirements contained in VDE 0100, VDE 0113, IEC 364, etc. must be complied with.

Prevention of material damage or personal injury

Additional external safety devices or facilities must be provided wherever significant material damage or even personal injury could result from a fault occurring in an automation system. A defined operating status must be ensured or forced by such devices or facilities (e.g. by independent limit switches, mechanical interlocks, etc.).

Advice concerning planning and installation of the products

- The safety and accident prevention measures applicable to a specific application are to be observed.
- In the case of mains-operated equipment, a check is to be made before putting it into operation to ensure that the preset mains voltage range is suitable for the local supply.
- In the case of a 24 V supply, care must be taken to ensure sufficient electrical insulation of the secondary side. Use only mains power supply units that conform to IEC 364-4-41 or HD 384.04.41 (VDE 0100 Part 410).
- Automation systems and their operating elements are to be installed in such a way that they are sufficiently protected against accidental operation.

Warranty

Selectron Systems Ltd. warrants its products to be free from defects in material and workmanship for a period of one year from the date of shipment. All claims under this warranty must be made within thirty (30) days of the discovery of the defect, and all defective products must be returned at the buyer's expense. Buyer's sole and exclusive right will be limited to, at the option of Selectron Systems Ltd., the repair or replacement by Selectron Systems Ltd., of any defective products for which a claim is made.

In all other matters please refer to the „General terms of business“ concerning Selectron Systems Ltd.

Note

The information given in this documentation corresponds to the state of development at the time of going to press and is therefore not binding. Selectron Systems Ltd. reserves the right to make alterations in the interests of technical advancement or product improvement at any time without giving reasons for doing so.

Prescriptions and standards

Mechanical data	
Housings in self-extinguishing plastic material. Protection mode IP 40	
Mounting: pluggable:	on plug-in socket 11 poles
Environmental conditions	
Admissible environmental temperatures from -25 °C ... +55 °C (corresponds IEC 68-1)	
Storage and transport temperature from -25 °C ... +70 °C	
Application class	IEC 721-3-3 (EN 60721-3-3)
Output relay	
Electrical lifetime:	230 Vac, min. 2×10^5 switching cycles at 1000 VA ohmic load.
Mechanical lifetime:	min. 20×10^6 switching cycles
Contact material	AgNi
Frequency range	48 ... 400 Hz / 24 ... 240 Vac, 16 ... 48 Hz / 24 ... 48 Vac
Duration of operation	100%
Protection	
Protection of the unit	5 A fast
Terminals plug-in socket	
Contact protection according VDE 0106 and VBG 4	
Terminal type:	sleeve with indirect screw pressure
Wire to connect:	rigid or flexible
Connecting limit:	4 mm ²
Terminal variants:	1 wire 0,5 mm ² ... 2,5 mm ² with/without wire end covers
	1 wire 4 mm ² without wire end covers
	2 wires 0,5 mm ² ... 1,5 mm ² with/without wire end covers
	2 wires 2,5 mm ² flexible without wire end covers
max. screw in torque:	0,5 Nm
Terminal screw for screw driver with PZ-1	
Insulation	
Isolation nominal voltage:	250 Vac (corresponds to IEC 60664-1)
Rating surge voltage:	4 kV, over-voltage category III, corresponds to IEC 60664-1
Electromagnetic compatibility	
Electrostatic discharge: Level 3, 6 kV contact, 8 kV air (corresponds to IEC 1000-4-2), EN 61000-4-2	
High frequency electromagnetic fields: Level 3, 10 V/m (corresponds to IEC 1000-4-3), EN 61000-4-3	
Fast transients: Level 4, 4 kV / 2,5 kHz, 5/50 ns (corresponds to IEC 1000-4-4), EN 61000-4-4	
Lightning discharge: Level 3, 2 kV com., 1 kV dif., (corresponds to IEC 1000-4-5, EN 61000-4-5)	
Cable running disturbances inducted by HF fields: Level 3, 10 V RMS (corresponds to IEC 1000-4-6), EN 61000-4-6	
Spurious radiation net and aerial network: Class B (corresponds to CISPR 22), EN 55011	
Prescriptions	
Air and leakage paces:	VDE 0110iGr. C/250, EN 50178 / VDE 0106
Test voltage:	VDE 0435 2000Vac, EN 50178 / VDE 0106
Low voltage directions according to EN 50178	
EMC emissions:	EN 55011
EMC interference stability:	Voltage impact strength according to IEC 1000-4-5, EN 61000-4-5
Burst:	EN 61 812-1 (level 3), EN 61000-4-4
ESD:	IEC 1000-4-2, EN 61000-4-2
HF over metallic circuits:	EN 50 082-2, ENPr 50141, EN55011
Electro magnetic HF field	according to EN 61000-4-3
Production standard:	according to ISO 9001

Monitoring Relay

Content

Monitoring relay industrial design

1-phase current monitoring relay	
EMR DI22F	2
Technical data.....	3
Function description	4
Connection	5
1-phase voltage monitoring relay	
EMR DU22E.....	6
Technical data.....	7
Function description	8
Connection	9
3-phase voltage monitoring relay	
EMR DU21D.....	10
Technical data.....	11
Connection	12
Function description	12
3-phase voltage monitoring relay (Multifunction)	
EMR DU21C1, EMR DU21D1, EMR DU21B1	14
Technical data.....	15
Function description	16
Connection	17
Temperature monitoring relay	
EMR DT22G.....	18
Technical data.....	19
Connection	20
Function description	20
Load monitoring	
EMR DP22H	22
Technical data.....	23
Function description	24
Connection	25
Frequency monitoring relay for 50/60 Hz power grids	
EMR DF22Q	26
Technical data.....	27
Function description	28
Connection	29
Accessories	
Protection cover.....	30
Mounting plate.....	30
Technical safety advice	31
Prescriptions and standards.....	32

Edition 10.12

Subject to technical changes and amendments to technical specifications at any time

1-phase current monitoring relay

EMR DI22F



EMR DI22F

- **AC/DC current monitoring in 1-phase mains**
- **Measuring range 100 mA / 1A / 10A ac/dc**
- **Multifunction**
- **16,6 ... 400 Hz**
- **Error Memory (Latch)**
- **2 change-over contacts**

Functions

ac/dc current monitoring in 1-phase mains with adjustable thresholds, timing for start-up suppression and tripping delay separately adjustable and the following functions (selectable by means of rotary switch)

- Overcurrent monitoring
- Overcurrent monitoring with error memory
- Undercurrent monitoring
- Undercurrent monitoring with error memory
- Monitoring the window between Min and Max
- Monitoring the window between Min and Max with error memory

Time ranges

Start-up suppression time: Adjustment range 0 ... 10 s

Tripping delay: Adjustment range 0.1 ... 10 s

Indicators

Green LED ON: indication of supply voltage

Green LED flashing: indication of start-up suppression time

Yellow LED ON/OFF: indication of relay output

Red LED ON/OFF: indication of failure of the corresponding threshold

Red LED flashing: indication of tripping delay of the corresponding threshold

Output relay

2 potential free change-over contacts

Rated voltage: 250 Vac

Switching capacity (distance <5 mm): 750 VA (3 A / 250 Vac)

Switching capacity (distance >5 mm): 1250 VA (5 A / 250 Vac)

Fusing: 5A fast acting

Connecting voltages

24 ... 240 Vdc, -20% ... +25% (galvanically separated)

24 ... 240 Vac, -15% ... +10% (galvanically separated)

100% duration of operation

Reference data

Selectron® EMR	Article no.
EMR DI22F 24 ... 240 Vac/dc	41230005
(Order data see chapter 1)	

1-phase current monitoring relay

EMR DI22F

Technical data	
Nominal consumption ⁴ .	5 VA / 1 W
Nominal frequency	48 ... 400 Hz (24 ... 240 Vac)
	16 ... 48 Hz (48 ... 240 Vac)
Wave form for ac	sine
Ripple at dc	10%
Drop-out voltage	>15% of the supply voltage
Base accuracy	±5% (of maximum scale value)
Adjustment accuracy	≤5% (of maximum scale value)
Repetition accuracy	≤2%
Temperature influence	≤0.1% / °C
Frequency response	-10% ... +5% (16.6 ... 400 Hz)
Recovery time	500 ms
Measuring circuit: Input:	
100 mA ac/dc	terminals K and I1(+)
1 A ac/dc	terminals K and I2(+)
10 A ac/dc	terminals K and I3(+)(distance >5 mm)
Overload capacity:	
100 mA ac/dc	800 mA
1 A ac/dc	3 A
10 A ac/dc	12 A
Input resistance:	
100 mA ac/dc	470 mΩ
1 A ac/dc	47 mΩ
10 A ac/dc	5 mΩ
Switching threshold:	
Max:	10% ... 100% of I _N
Min:	5% ... 95% of I _N

Type key

EMR D U 2 1 C 1

Construction

D Industrial design 22.5 mm
S pluggable 11 poles

Function

U Voltage
I Current
P CosPhi
T Temperature
S Star-Delta
F Frequency

Output

1 1 changer
2 2 changers
3 1 NC contact / 1 NO contact

Special functions

1 = Additional asymmetry monitoring

Measuring circuit

A No measuring circuit	I 12 Vdc
B 3(N)~115/66 Vac	J 24 Vdc
C 3(N)~230/132 Vac	K 36 Vdc
D 3(N)~400/230 Vac	L 48 Vdc
E 1 ≅ 30/60/300 Vac/dc	M 1~110 Vac
F 1 ≅ 100mA/1A/10A ac/dc	N 1~230 Vac
G PTC	O 1 A
H CosPhi	P 5 A
	Q 50/60 Hz 110... 400 Vac

Connecting voltage

1 Measuring circuit
2 24...240 Vac/dc
3 230 Vac

1-phase current monitoring relay

EMR DI22F

Function description

When the supply voltage U is applied, the output relays switch into on-position (yellow LED illuminated) and the set interval of the start-up suppression (START) begins (green LED U flashes). Changes of the measured current during this period do not affect the state of the output relay. After the interval has expired the green LED is illuminated steadily.

For all the functions the LEDs MIN and MAX are flashing alternating, when the minimum value for the measured current was chosen to be greater than the maximum value.

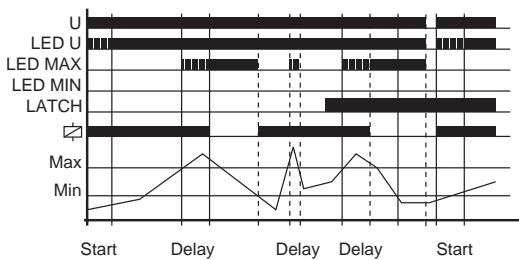

Overcurrent monitoring (OVER, OVER+LATCH)

When the measured current exceeds the value adjusted at the MAX-regulator, the set interval of the tripping delay (DELAY) begins (red LED MAX flashes). After the interval has expired (red LED MAX illuminated), the output relays switch into off-position (yellow LED not illuminated). The output relays again switch into on-position (yellow LED illuminated), when the measured current falls below the value adjusted at the MIN-regulator (red LED MAX not illuminated).

If the error memory is activated (OVER+LATCH) and the measured current remains above the MAX-value longer than the set interval of the tripping delay, the output relays remain in the off-position even if the measured current falls below the value adjusted at the MIN-regulator. After resetting the failure (interrupting and re-applying the supply voltage), the output relays switch into on-position and a new measuring cycle begins with the set interval of the start-up suppression (START).

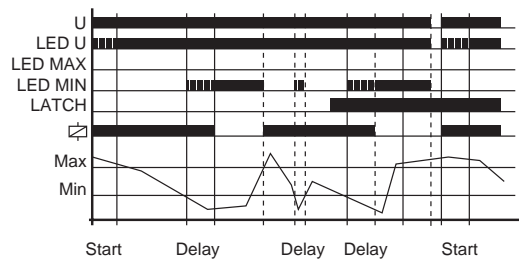

Undercurrent monitoring (UNDER, UNDER+LATCH)

When the measured current falls below the value adjusted at the MIN-regulator, the set interval of the tripping delay (DELAY) begins (red LED MIN flashes). After the interval has expired (red LED MIN illuminated), the output relays switch into off-position (yellow LED not illuminated). The output relays again switch into on-position (yellow LED illuminated), when the measured current exceeds the value adjusted at the MAX-regulator.

If the error memory is activated (UNDER+LATCH) and the measured current remains below the MIN-value longer than the set interval of the tripping delay, the output relays remain in the off-position even if the measured current exceeds the value adjusted at the MAX-regulator. After resetting the failure (interrupting and re-applying the supply voltage), the output relays switch into on-position and a new measuring cycle begins with the set interval of the start-up suppression (START).

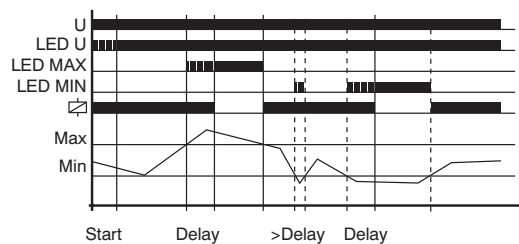

Window function (WIN, WIN+LATCH)

The output relays switch into on-position (yellow LED illuminated) when the measured current exceeds the value adjusted at the MIN-regulator. When the measured current exceeds the value adjusted at the MAX-regulator, the set interval of the tripping delay (DELAY) begins (red LED MAX flashes). After the interval has expired (red LED MAX illuminated), the output relays switch into off-position (yellow LED not illuminated). The output relays again switch into on-position (yellow LED illuminated) when the measured current falls below the value adjusted at the MAX-regulator (red LED MAX not illuminated). When the measured current falls below the value adjusted at the MIN-regulator, the set interval of the tripping delay (DELAY) begins again (red LED MIN flashes). After the interval has expired (red LED MIN illuminated), the output relays switch into off-position (yellow LED not illuminated).

1-phase current monitoring relay

EMR DI22F

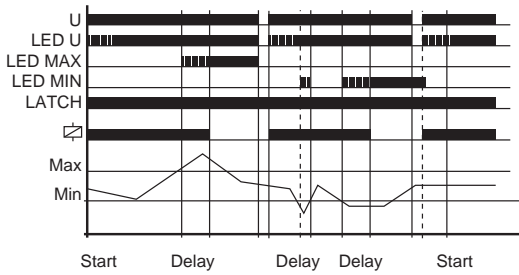

If the error memory is activated (WIN+LATCH) and the measured current remains below the MIN-value longer than the set interval of the tripping delay, the output relays remain in the off-position even if the measured current exceeds the value adjusted at the MIN-regulator. If the measured current remains above the MAX-value longer than the set interval of the tripping delay, the output relays remain in the off-position even if the measured current falls below the value adjusted at the MAX-regulator. After resetting the failure (interrupting and re-applying the supply voltage), the output relays switch into on-position and a new measuring cycle begins with the set interval of the start-up suppression (START).

Connection

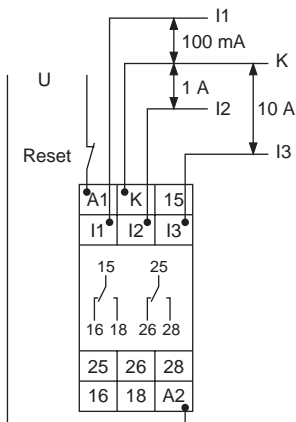

With error memory
Measuring range 100 mA, 1 A or 10 A
U = supply voltage 24 ... 240 Vac/dc

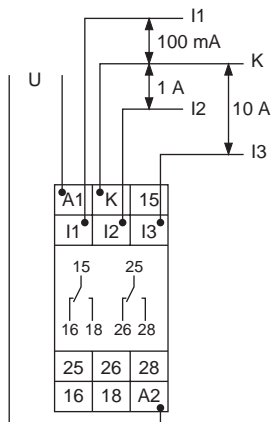

Without error memory
Measuring range 100 mA, 1 A or 10 A
U = supply voltage 24 ... 240 Vac/dc

Dimensions

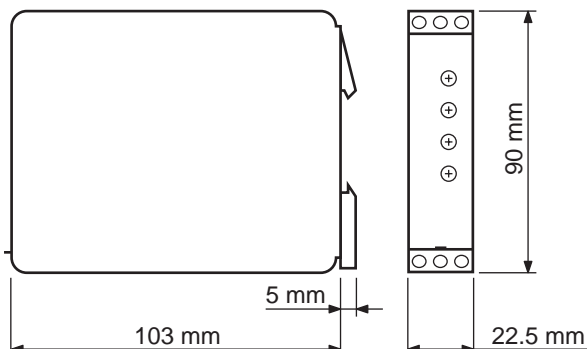

1-phase voltage monitoring relay

EMR DU22E



EMR DU22E

- ac/dc voltage monitoring in 1-phase mains
- Measuring range 30/60/300 Vac/dc
- Multifunction
- 16,6 ... 400 Hz
- Error Memory (Latch)
- 2 change-over contacts

Functions

ac/dc voltage monitoring in 1-phase mains with adjustable thresholds, timing for start-up suppression and tripping delay separately adjustable and the following functions (selectable by means of rotary switch)

- Overvoltage monitoring
- Overvoltage monitoring with error memory
- Undervoltage monitoring
- Undervoltage monitoring with error memory
- Monitoring the window between Min and Max
- Monitoring the window between Min and Max with error memory

Time ranges

Start-up suppression time: Adjustment range 0 ... 10 s
Tripping delay: Adjustment range 0.1 ... 10 s

Indicators

Green LED ON: indication of supply voltage
Green LED flashing: indication of start-up suppression time
Yellow LED ON/OFF: indication of relay output
Red LED ON/OFF: indication of failure of the corresponding threshold
Red LED flashing: indication of tripping delay of the corresponding threshold

Output relay

2 potential free change-over contacts
Rated voltage: 250 Vac
Switching capacity (distance <5 mm): 750 VA (3 A / 250 Vac)
Switching capacity (distance >5 mm): 1250 VA (5 A / 250 Vac)
Fusing: 5A fast acting

Connecting voltages

24 ... 240 Vdc, -20% ... +25% (galvanically separated)
24 ... 240 Vac, -15% ... +10% (galvanically separated)
100% duration of operation

Reference data

Selectron® EMR	Article no.
DU22E 24 ... 240 Vac/dc	41230004
(Order data see chapter 1)	

1-phase voltage monitoring relay

EMR DU22E

Technical data	
Nominal consumption	4.5 VA / 1 W
Nominal frequency	48 ... 400 Hz (24 ... 240 Vac)
	16 ... 48 Hz (48 ... 240 Vac)
Wave form for ac	sine
Ripple at dc	10%
Drop-out voltage	>15% of the supply voltage
Base accuracy	±5% (of maximum scale value)
Adjustment accuracy	≤5% (of maximum scale value)
Repetition accuracy	≤2%
Temperature influence	≤0.1% / °C
Frequency response	-10% ... +5% (16.6 ... 400 Hz)
Voltage influence	≤0.5%
Recovery time	500 ms
Measuring circuit: Fusing max. 20 A (according to UL 508)	
Measured variable	dc or ac sine (16.6 ... 400 Hz)
Input:	
30 Vac/dc	terminals E and F1(+)
60 Vac/dc	terminals E and F2(+)
300 Vac/dc	terminals E and F3(+)
Overload capacity:	
30 Vac/dc	100 V _{eff}
60 Vac/dc	150 V _{eff}
300 Vac/dc	440 V _{eff}
Input resistance:	
30 Vac/dc	47 kΩ
60 Vac/dc	100 kΩ
300 Vac/dc	470 kΩ
Switching threshold:	
Max:	10% ... 100% from U _N
Min:	5% ... 95% from U _N

Type key

EMR D U 2 2 E ...

Construction

- D** Industrial design 22.5 mm
- S** pluggable 11 poles

Function

- U** Voltage
- I** Current
- P** CosPhi
- T** Temperature
- S** Star-Delta
- F** Frequency

Output

- 1** 1 changer
- 2** 2 changers
- 3** 1 NC contact / 1 NO contact

Special functions

- 1** = Additional asymmetry monitoring

Measuring circuit

- | | |
|---------------------------------|----------------------------------|
| A No measuring circuit | I 12 Vdc |
| B 3(N)~115/66 Vac | J 24 Vdc |
| C 3(N)~230/132 Vac | K 36 Vdc |
| D 3(N)~400/230 Vac | L 48 Vdc |
| E 1 ≙ 30/60/300 Vac/dc | M 1~110 Vac |
| F 1 ≙ 100mA/1A/10A ac/dc | N 1~230 Vac |
| G PTC | O 1 A |
| H CosPhi | P 5 A |
| | Q 50/60 Hz 110... 400 Vac |

Connecting voltage

- 1** Measuring circuit
- 2** 24...240 Vac/dc
- 3** 230 Vac

1-phase voltage monitoring relay

EMR DU22E

Function description

When the supply voltage U is applied, the output relays switch into on-position (yellow LED illuminated) and the set interval of the start-up suppression (START) begins (green LED U flashes). Changes of the measured voltage during this period do not affect the state of the output relay. After the interval has expired the green LED is illuminated steadily.

For all the functions the LEDs MIN and MAX are flashing alternating, when the minimum value for the measured voltage was chosen to be greater than the maximum value.

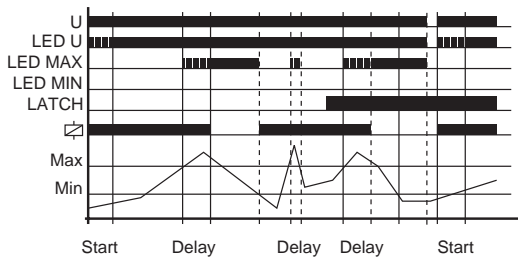

Overvoltage monitoring (OVER, OVER+LATCH)

When the measured voltage exceeds the value adjusted at the MAX-regulator, the set interval of the tripping delay (DELAY) begins (red LED MAX flashes). After the interval has expired (red LED MAX illuminated), the output relays switch into off-position (yellow LED not illuminated). The output relays again switch into on-position (yellow LED illuminated), when the measured voltage falls below the value adjusted at the MIN-regulator (red LED MAX not illuminated).

If the error memory is activated (OVER+LATCH) and the measured voltage remains above the MAX-value longer than the set interval of the tripping delay, the output relays remain in the off-position even if the measured voltage falls below the value adjusted at the MIN-regulator. After resetting the failure (interrupting and re-applying the supply voltage), the output relays switch into on-position and a new measuring cycle begins with the set interval of the start-up suppression (START).

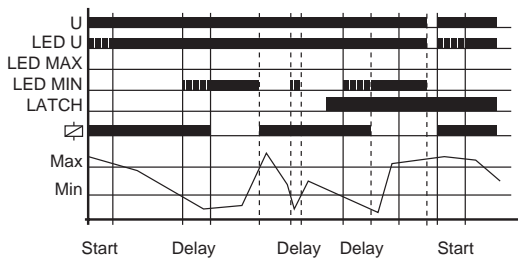

Undervoltage monitoring (UNDER, UNDER+LATCH)

When the measured voltage falls below the value adjusted at the MIN-regulator, the set interval of the tripping delay (DELAY) begins (red LED MIN flashes). After the interval has expired (red LED MIN illuminated), the output relays switch into off-position (yellow LED not illuminated). The output relays again switch into on-position (yellow LED illuminated), when the measured voltage exceeds the value adjusted at the MAX-regulator.

If the error memory is activated (UNDER+LATCH) and the measured voltage remains below the MIN-value longer than the set interval of the tripping delay, the output relays remain in the off-position even if the measured voltage exceeds the value adjusted at the MAX-regulator. After resetting the failure (interrupting and re-applying the supply voltage), the output relays switch into on-position and a new measuring cycle begins with the set interval of the start-up suppression (START).

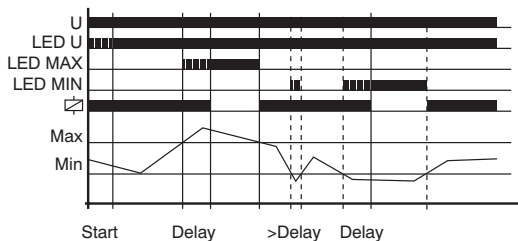

Window function (WIN, WIN+LATCH)

The output relays switch into on-position (yellow LED illuminated) when the measured voltage exceeds the value adjusted at the MIN-regulator. When the measured voltage exceeds the value adjusted at the MAX-regulator, the set interval of the tripping delay (DELAY) begins (red LED MAX flashes). After the interval has expired (red LED MAX illuminated), the output relays switch into off-position (yellow LED not illuminated). The output relays again switch into on-position (yellow LED illuminated) when the measured voltage falls below the value adjusted at the MAX-regulator (red LED MAX not illuminated). When the measured voltage falls below the value adjusted at the MIN-regulator, the set interval of the tripping delay (DELAY) begins again (red LED MIN flashes). After the interval has expired (red LED MIN illuminated), the output relays switch into off-position (yellow LED not illuminated).

1-phase voltage monitoring relay

EMR DU22E

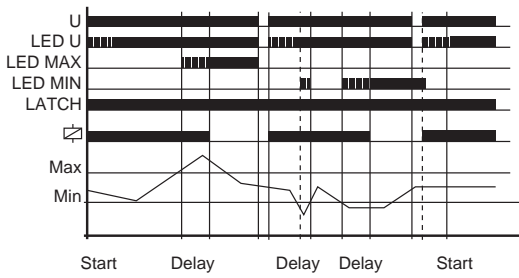

If the error memory is activated (WIN+LATCH) and the measured voltage remains below the MIN-value longer than the set interval of the tripping delay, the output relays remain in the off-position even if the measured voltage exceeds the value adjusted at the MIN-regulator. If the measured voltage remains above the MAX-value longer than the set interval of the tripping delay, the output relays remain in the off-position even if the measured voltage falls below the value adjusted at the MAX-regulator. After resetting the failure (interrupting and re-applying the supply voltage), the output relays switch into on-position and a new measuring cycle begins with the set interval of the start-up suppression (START).

Connection

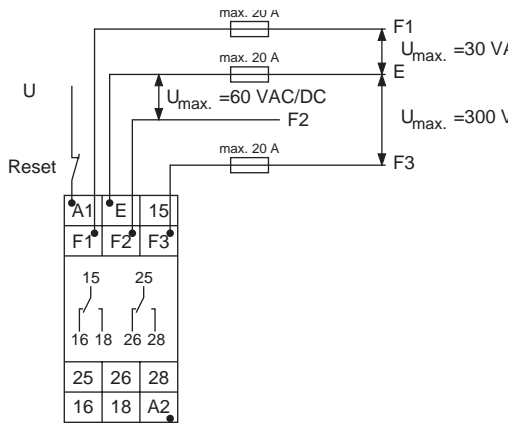

With error memory
 Measuring range U_{max} 30, 60 or 300 Vac/dc
 U = supply voltage 24 ... 240 Vac/dc

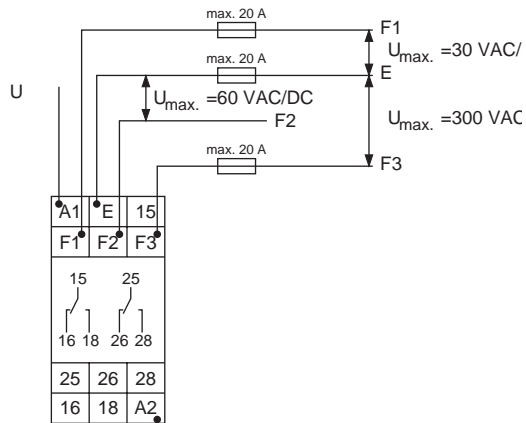

Without error memory
 Measuring range U_{max} 30, 60 or 300 Vac/dc
 U = supply voltage 24 ... 240 Vac/dc

Dimensions

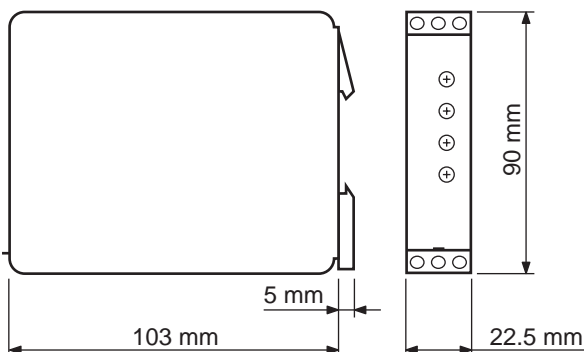

3-phase voltage monitoring relay

EMR DU21D



EMR DU21D

- **Voltage monitoring in 3-phase mains**
- **Measuring range 230 ... 400 Vac 3Ph**
- **Monitoring of phase sequence and phase failure**
- **Detection of reverse voltage**
- **Connection of neutral wire optional**
- **2 changers**

Functions

Monitoring of phase sequence, phase failure and detection of return voltage (by means of evaluating the asymmetry).

Time ranges

Start-up suppression time: max. 500 ms

Tripping delay: max. 350 ms

Indicators

Green LED ON: indication of supply voltage

Yellow LED ON/OFF: indication of relay output

Output relay

2 potential free change-over contacts

Rated voltage: 250 Vac

Switching capacity (distance <5 mm): 750 VA (3 A / 250 Vac)

Switching capacity (distance >5 mm): 1250 VA (5 A / 250 Vac)

Fusing: 5A fast acting

Connecting voltages

3(N) ~230/400 V, Terminals (N)-L1-L2-L3 (= supply voltage)

Tolerance: 3(N) ~230/400 V, 3(N) ~342 ... 457 V

Reference data

Selectron® EMR	Article no.
DU21D 230 ... 400 Vac 3Ph	41230001
(Order data see chapter 1)	

3-phase voltage monitoring relay

EMR DU21D

Technical data	
Nominal consumption	3(N) ~230/400 V, 9 VA
Nominal frequency	48 ... 63 Hz
Drop-out voltage	>20% of the supply voltage
Recovery time	500 ms
Measuring circuit: Input:	
3(N) ~230/400 V	Terminals (N)-L1-L2-L3 (= supply voltage)
Overload capacity:	
3(N) ~230/400 V	3(N) ~264/457 V
Input resistance:	
3(N) ~230/400 V	15 kΩ
Asymmetry:	typ. 30%

Type key

EMR D U 2 1 D ...

Construction

D Industrial design 22.5 mm
S pluggable 11 poles

Function

U Voltage
I Current
P CosPhi
T Temperature
S Star-Delta
F Frequency

Output

1 1 changer
2 2 changers
3 1 NC contact / 1 NO contact

Special functions

1 = Additional asymmetry monitoring

Measuring circuit

A No measuring circuit	I 12 Vdc
B 3(N)~115/66 Vac	J 24 Vdc
C 3(N)~230/132 Vac	K 36 Vdc
D 3(N)~400/230 Vac	L 48 Vdc
E 1 ≅ 30/60/300 Vac/dc	M 1~110 Vac
F 1 ≅ 100mA/1A/10A ac/dc	N 1~230 Vac
G PTC	O 1 A
H CosPhi	P 5 A
	Q 50/60 Hz 110... 400 Vac

Connecting voltage

1 Measuring circuit
2 24...240 Vac/dc
3 230 Vac

3-phase voltage monitoring relay

EMR DU21D

Function description

Phase sequence monitoring

When all the phases are connected in the correct sequence and the measured asymmetry is less than the fixed value, the output relays switch into on-position (yellow LED illuminated). When the phase sequence changes, the output relays switch into off-position (yellow LED not illuminated).

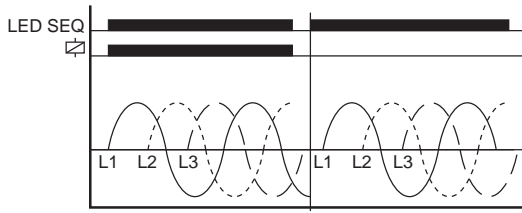

Phase failure monitoring

When one of the three phases fails, the output relays switch into off-position (yellow LED not illuminated).

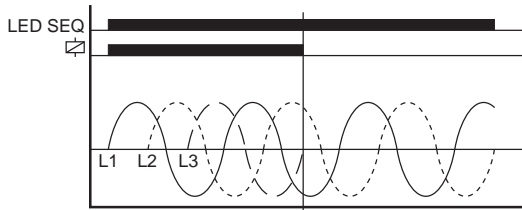

Detection of reverse voltage (by means of evaluation of asymmetry)

The output relays switch into off-position (yellow LED not illuminated) when the asymmetry between the phase voltages exceeds the fixed value of the asymmetry.

An asymmetry caused by the reverse voltage of a consumer (e.g. a motor which continues to run on two phases only) does not effect the disconnection.

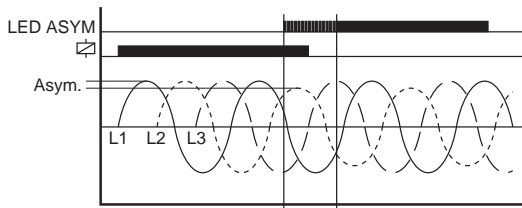

Connection

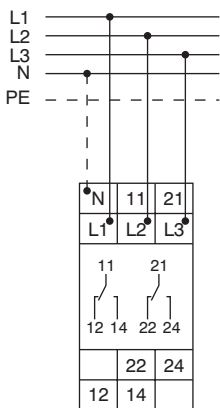

Dimensions

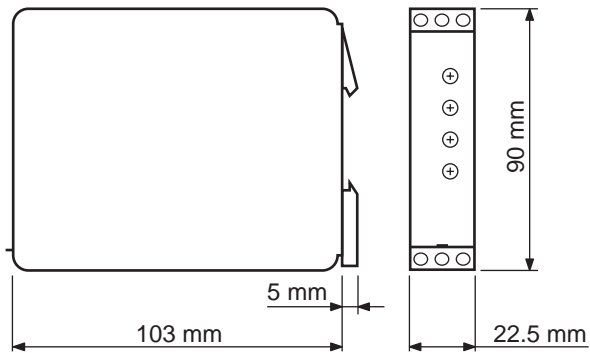

3-phase voltage monitoring relay (Multifunction)

EMR DU21C1, EMR DU21D1, EMR DU21B1



EMR DU21C1



EMR DU21D1

- Voltage monitoring in 3-phase mains
- Measuring range 66...115 / 132...230 / 230...400 Vac 3Ph
- Multifunction
- Monitoring of phase sequence and phase failure
- Additional asymmetry monitoring
- Connection of neutral wire optional
- 2 changers

Functions

Voltage monitoring in 3-phase mains with adjustable thresholds, adjustable tripping delay, monitoring of phase sequence and phase failure, monitoring of asymmetry with adjustable threshold and the following functions (selectable by means of rotary switch)

- Undervoltage monitoring
- Undervoltage monitoring and monitoring of phase sequence
- Monitoring of window between Min and Max
- Monitoring the window between Min and Max and monitoring of phase sequence.

Time ranges

Start-up suppression time:-

Tripping delay: Adjustment range 0.1 ... 10 s

Indicators

Red LED ON/OFF: indication of failure of the corresponding threshold

Red LED flashes: indication of tripping delay of the corresponding threshold

Yellow LED ON/OFF: indication of relay output

Output relay

2 potential free change-over contacts

Rated voltage: 250 Vac

Switching capacity (distance <5 mm): 750 VA (3 A / 250 Vac)

Switching capacity (distance >5 mm): 1250 VA (5 A / 250 Vac)

Fusing: 5A fast acting

Connecting voltages

24 ... 240 Vac/dc, Terminals A1-A2 (galvanically separated)

Tolerance: 24 ... 240 Vdc, -20% ... +25% (galvanically separated)

24 ... 240 Vac, -15% ... +10% (galvanically separated)

100% duration of operation

Reference data

Selectron® EMR	Article no.
DU21D1 230 ... 400 Vac 3Ph	41230002
DU21C1 132 ... 230 Vac 3Ph	41230003

(Order data see chapter 1)

3-phase voltage monitoring relay (Multifunction)

EMR DU21C1, EMR DU21D1, EMR DU21B1

Technical data	
Nominal consumption	3(N) ~132/230 V, 4,5 VA (1 W) (EMR DU21C1) 3(N) ~230/400 V, 4,5 VA (1 W) (EMR DU21D1) 3(N) ~ 66/115 V, 4,5 VA (1 W) (EMR DU21B1)
Nominal frequency	48 ... 400 Hz (24 ... 240 Vac) 16 ... 48 Hz (48 ... 240 Vac)
Wave form for ac	sine
Ripple at dc	10%
Drop-out voltage	>15% of the supply voltage
Base accuracy	±5% (of maximum scale value)
Adjustment accuracy	≤5% (of maximum scale value)
Repetition accuracy	≤2%
Temperature influence	≤0.1% / °C
Recovery time	500 ms
Measuring circuit:	Fusing max. 20 A (according to UL 508)
Measured variable	ac sine (48 ... 63 Hz)
Input:	
3(N) ~132/230 V	Terminals (N)-L1-L2-L3 (EMR DU21C1)
3(N) ~230/400 V	Terminals (N)-L1-L2-L3 (EMR DU21D1)
3(N) ~ 66/115 V	Terminals (N)-L1-L2-L3 (EMR DU21B1)
Overload capacity:	
3(N) ~132/230 V	3(N) ~199/345 V (EMR DU21C1)
3(N) ~230/400 V	3(N) ~346/600 V (EMR DU21D1)
3(N) ~ 66/115 V	3(N) ~100/173 V (EMR DU21B1)
Input resistance:	
3(N) ~132/230 V	470 kΩ (EMR DU21C1)
3(N) ~230/400 V	1 MΩ (EMR DU21D1)
3(N) ~ 66/115 V	220 kΩ (EMR DU21B1)
Switching threshold:	
Max:	-20% ... +30% von U_N
Min:	-30% ... +20% von U_N
Asymmetry:	5% ... 25%

Type key

EMR D U 2 1 C 1

Construction

- D** Industrial design 22.5 mm
S pluggable 11 poles

Function

- U** Voltage
I Current
P CosPhi
T Temperature
S Star-Delta
F Frequency

Output

- 1** 1 changer
2 2 changers
3 1 NC contact / 1 NO contact

Special functions

- 1** = Additional asymmetry monitoring

Measuring circuit

- | | |
|---------------------------------|----------------------------------|
| A No measuring circuit | I 12 Vdc |
| B 3(N)~115/66 Vac | J 24 Vdc |
| C 3(N)~230/132 Vac | K 36 Vdc |
| D 3(N)~400/230 Vac | L 48 Vdc |
| E 1 ≙ 30/60/300 Vac/dc | M 1~110 Vac |
| F 1 ≙ 100mA/1A/10A ac/dc | N 1~230 Vac |
| G PTC | O 1 A |
| H CosPhi | P 5 A |
| | Q 50/60 Hz 110... 400 Vac |

Connecting voltage

- 1** Measuring circuit
2 24...240 Vac/dc
3 230 Vac

3-phase voltage monitoring relay (Multifunction)

EMR DU21C1, EMR DU21D1, EMR DU21B1

Function description

For all the functions the LEDs MIN and MAX are flashing alternating, when the minimum value for the measured voltage was chosen to be greater than the maximum value.

If a failure already exists when the device is activated, the output relays remain in off-position and the LED for the corresponding threshold is illuminated.

Under voltage monitoring (UNDER, UNDER+SEQ)

When the measured voltage (mean value of phase-to-phase voltages) falls below the value adjusted at the MIN-regulator, the set interval of the tripping delay (DELAY) begins (red LED MIN flashes). After the interval has expired (red LED MIN illuminated), the output relays switch into off-position (yellow LED not illuminated). The output relays again switch into on-position (yellow LED illuminated), when the measured voltage exceeds the value adjusted at the MAX-regulator.

Window function (WIN, WIN+SEQ)

The output relays switch into on-position (yellow LED illuminated) when the measured voltage (mean value of phase-to-phase voltages) exceeds the value adjusted at the MIN-regulator. When the measured voltage exceeds the value adjusted at the MAX-regulator, the set interval of the tripping delay (DELAY) begins (red LED MAX flashes). After the interval has expired (red LED MAX illuminated), the output relays switch into off-position (yellow LED not illuminated). The output relays again switch into on-position (yellow LED illuminated) when the measured voltage falls below the value adjusted at the MAX-regulator (red LED MAX not illuminated). When the measured voltage falls below the value adjusted at the MIN-regulator, the set interval of the tripping delay (DELAY) begins again (red LED MIN flashes). After the interval has expired (red LED MIN illuminated), the output relays switch into off-position (yellow LED not illuminated).

Phase sequence monitoring (SEQ)

Phase sequence monitoring is selectable for all functions.

If a change in phase sequence is detected (red LED SEQ illuminated), the output relays switch into off-position immediately (yellow LED not illuminated).

Phase failure monitoring (SEQ)

If one of the phase voltages fails, the set interval of the tripping delay (DELAY) begins (red LED SEQ flashes). After the interval has expired (red LED SEQ illuminated), the output relays switch into off-position (yellow LED not illuminated).

Reverse voltages of a consumer (e.g. a motor which continues to run on two phases only) do not effect the disconnection but can be monitored by using a proper value for the asymmetry.

Asymmetry monitoring

If the asymmetry of the phase-to-phase voltages exceeds the value set at the ASYM-regulator, the set interval of the tripping delay (DELAY) begins (red LED ASYM flashes). After the interval has expired (red LED ASYM illuminated), the output relays switch into off-position (yellow LED not illuminated).

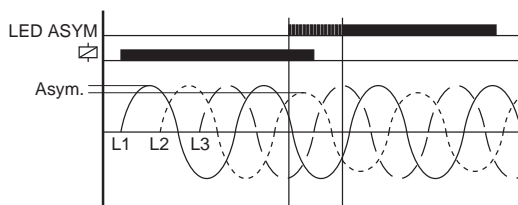
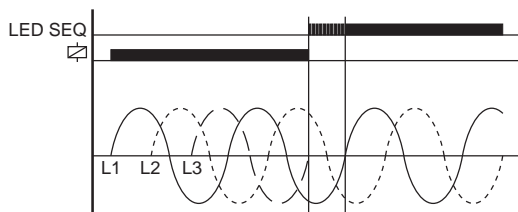
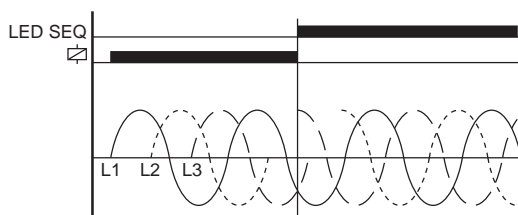
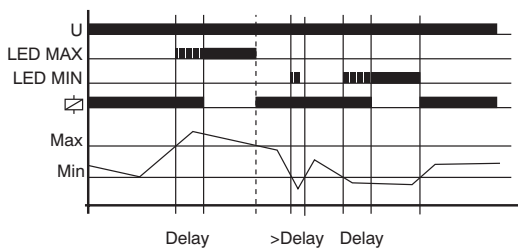
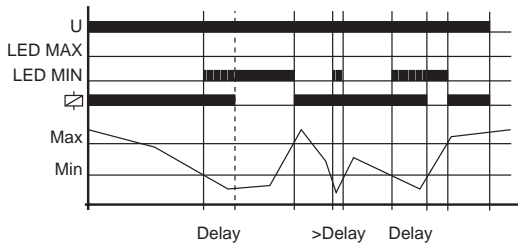

3-phase voltage monitoring relay (Multifunction)

EMR DU21C1, EMR DU21D1, EMR DU21B1

If the neutral wire is connected to the device, the asymmetry of the phase voltages referred to the neutral wire (Y-voltage) is monitored also. In that case both values of the asymmetry are evaluated and if one of the values exceeds the value set at the ASYM-regulator, the set interval of the tripping delay (DELAY) begins (red LED ASYM flashes). After the interval has expired (red LED ASYM illuminated), the output relays switch into off-position (yellow LED not illuminated).

Shift of the star-point (asymmetry) through unequal phase-load with missing neutral wire

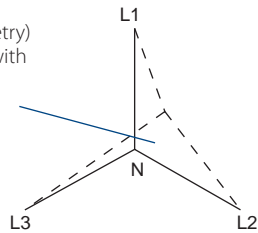

Loss of neutral wire by means of evaluation of asymmetry

A break of the neutral wire between power line and machinery is detected as soon as asymmetry between phase-to-phase voltage and neutral wire occurs. If the asymmetry exceeds the value set at the ASYM-regulator, the set interval of the tripping delay (DELAY) begins (red LED ASYM flashes). After the interval has expired (red LED ASYM illuminated), the output relays switch into off-position (yellow LED not illuminated). A break of the neutral wire between our device and the machinery can not be detected.

Connection

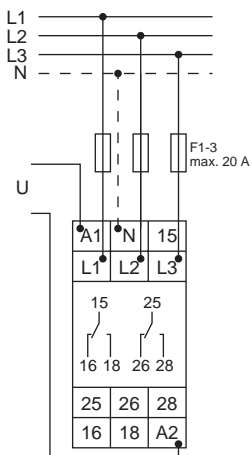

Supply voltage 24 ... 240 Vac/dc

Dimensions

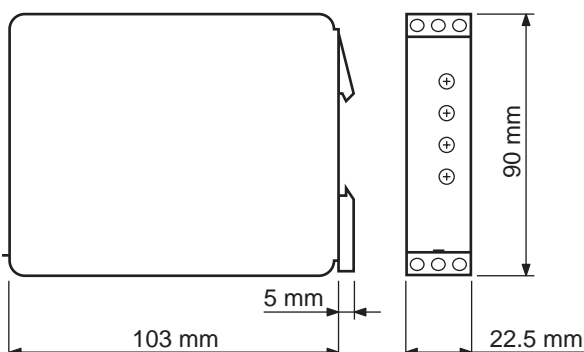

Temperature monitoring relay

EMR DT22G



EMR DT22G

- Temperature monitoring of the motor winding
- 2 changers
- External reset key connectable

Functiones

Temperature monitoring of the motor winding (max. 6 PTC) with fault latch, for temperature probes in accordance with DIN 44081.

Test function with integrated test/reset key.

Indicators

Green LED ON: indication of supply voltage
Red LED ON/OFF: indication of failure

Output relay

2 potential free change-over contacts

Rated voltage: 250 Vac

Switching capacity (distance <5 mm): 750 VA (3 A / 250 Vac)

Switching capacity (distance >5 mm): 1250 VA (5 A / 250 Vac)

Fusing: 5A fast acting

Connecting voltages

24 ... 240 Vac/dc, Terminals A1-A2 (galvanically separated)

Tolerance: 24 ... 240 Vdc, -20% ... +25% (galvanically separated)

24 ... 240 Vac, -15% ... +10% (galvanically separated)

100% duration of operation

Reference data

Selectron® EMR	Article no.
DT22G 24 ... 240 Vac/dc	41230006
(Order data see chapter 1)	

Temperature monitoring relay

EMR DT22G

Technical data	
Nominal consumption	4.5 VA / 1 W
Nominal frequency	48 ... 400 Hz (24 ... 240 Vac)
	16 ... 48 Hz (48 ... 240 Vac)
Wave form for ac	sine
Ripple at dc	10%
Drop-out voltage	>15% of the supply voltage
Base accuracy	±10% (of maximum scale value)
Repetition accuracy	≤1%
Temperature influence	≤0.1% / °C
Recovery time	500 ms
Measuring circuit:	Terminals T1-T2
Initial resistance	<1.5 kΩ
Response value (relay in off-position)	≥3.6 kΩ
Release value (relay in on-position)	≤1.8 kΩ
Disconnection (short circuit thermistor)	No
Measuring voltage T1-T2	≤2.5 Vdc at R ≤4.0 kΩ
	(according to DIN VDE 0660 Teil 302)

Type key

EMR D T 2 2 G ...

Construction

D Industrial design 22.5 mm
S pluggable 11 poles

Function

U Voltage
I Current
P CosPhi
T Temperature
S Star-Delta
F Frequency

Output

1 1 changer
2 2 changers
3 1 NC contact / 1 NO contact

Special functions

1 = Additional asymmetry monitoring

Measuring circuit

A No measuring circuit	I 12 Vdc
B 3(N)~115/66 Vac	J 24 Vdc
C 3(N)~230/132 Vac	K 36 Vdc
D 3(N)~400/230 Vac	L 48 Vdc
E 1 ≅ 30/60/300 Vac/dc	M 1~110 Vac
F 1 ≅ 100mA/1A/10A ac/dc	N 1~230 Vac
G PTC	O 1 A
H CosPhi	P 5 A
	Q 50/60 Hz 110... 400 Vac

Connecting voltage

1 Measuring circuit
2 24...240 Vac/dc
3 230 Vac

Temperature monitoring relay

EMR DT22G

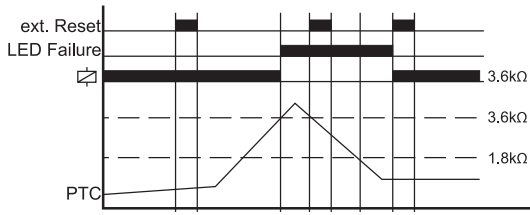

Function description

If the supply voltage U is applied (green LED illuminated) and the cumulative resistance of the PTC-circuit is less than $3.6k\Omega$ (standard temperature of the motor), the output relays switch into on-position.

Pressing the test/reset key under this conditions forces the output relays to switch into off-position. They remain in this state as long as the test/reset key is pressed and thus the switching function can be checked in case of fault. The test function is not effective using an external reset key.

When the cumulative resistance of the PTC-circuit exceeds $3.6k\Omega$ (at least one of the PTCs has reached the cut-off temperature), the output relays switch into off-position (red LED illuminated).

The output relays again switch into on-position (red LED not illuminated), if the cumulative resistance drops below $1.8k\Omega$ by cooling down of the PTC and either a reset key (internal or external) was pressed or the supply voltage was disconnected and re-applied.

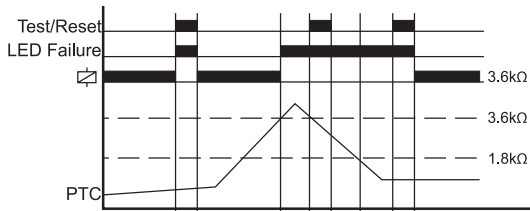

Connection

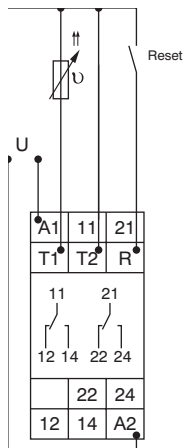

Dimensions

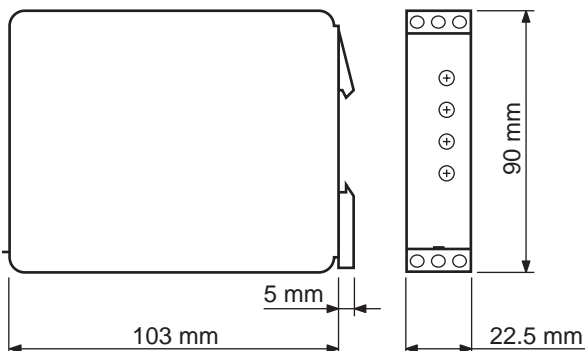

Load monitoring

EMR DP22H



EMR DP22H

- **Power factor monitoring ($\cos\phi$) in 1- or 3-phase mains**
- **Multifunction**
- **Error memory (LATCH)**
- **Recognition of disconnected consumers**
- **Suitable for VFI (10 to 100 Hz)**
- **2 changers**

Functions

Load monitoring ($\cos \phi$) in 1- or 3-phase mains with adjustable thresholds, timing for start-up suppression and tripping delay separately adjustable and the following functions selectable by means of rotary switch.

OVER	Overload monitoring
OVER+LATCH	Overload monitoring with error memory
UNDER	Underload monitoring
UNDER+LATCH	Underload monitoring with error memory
WIN	Monitoring the window between Min and Max
WIN+LATCH	Monitoring the window between Min and Max with error memory

Time ranges

Start-up suppression time:	Adjustment range 1 ... 100 s
Tripping delay:	Adjustment range 0.1 ... 40 s

Indicators

Green LED ON:	indication of supply voltage
Green LED flashing:	indication of start-up suppression time
Yellow LED R ON/OFF:	indication of relay output
Yellow LED I=0 ON/OFF:	indication of disconnected consumers
Red LED ON/OFF:	indication of failure of the corresponding threshold
Red LED flashing:	indication of tripping delay of the corresponding threshold

Output relay

2 potential free change-over contacts	
Rated voltage:	250 Vac
Switching capacity (distance <5 mm):	750 VA (3 A / 250 Vac)
Switching capacity (distance >5 mm):	1250 VA (5 A / 250 Vac)
Fusing:	5A fast acting

Connecting voltages

24 ... 240 Vac/dc, Terminals A1-A2 (galvanically separated)	
Tolerance:	24 ... 240 Vdc, -20% ... +25% (galvanically separated)
	24 ... 240 Vac, -15% ... +10% (galvanically separated)
100% duration of operation	

Reference data

Selectron® EMR	Article no.
DP22H 24 ... 240 Vac/dc	41230008
(Order data see chapter 1)	

Load monitoring

EMR DP22H

Technical data	
Nominal consumption	4.5 VA / 1 W
Nominal frequency	48 ... 400 Hz (24 ... 240 Vac)
	16 ... 48 Hz (48 ... 240 Vac)
Ripple at dc	10%
Drop-out voltage	>15% of the supply voltage
Base accuracy	±5° (equivalent to 5% at cos φ = 0.8)
Repetition accuracy	±1.8° (equivalent to 1.8% at cos φ = 0.8)
Adjustment accuracy	≤5% (at cos φ = 0.8)
Temperature influence	≤0.1% / °C
Recovery time	500 ms
Measuring circuit:	
Measured variable	ac sine (10 ... 100 Hz)
Measuring-input voltage:	
1-phase mains	40 ... 415 Vac (300 V gegen Erde), terminals L1i-L2/L3
3-phase mains	3~ 23/40 bis 240/415 V, terminals L1i-L2-L3
Overload capacity:	
1-phase mains	500 V
3-phase mains	3~ 289/500 V
Input resistance	>1 MΩ
Measuring-input current	0.5 ... 10 A, terminals L1i-L1k (for I>8 A distance >5 mm)
Overload capacity	12 A permanently
Input resistance	5 mΩ
Switching threshold cos φ	
Max.	0.2 ... 1.0
Min.	0.1 ... 0.99

Type key

EMR D P 2 2 H ...

Construction

D Industrial design 22.5 mm
S pluggable 11 poles

Function

U Voltage
I Current
P CosPhi
T Temperature
S Star-Delta
F Frequency

Output

1 1 changer
2 2 changers
3 1 NC contact / 1 NO contact

Special functions

1 = Additional asymmetry monitoring

Measuring circuit

A No measuring circuit	I 12 Vdc
B 3(N)~115/66 Vac	J 24 Vdc
C 3(N)~230/132 Vac	K 36 Vdc
D 3(N)~400/230 Vac	L 48 Vdc
E 1 ≅ 30/60/300 Vac/dc	M 1~110 Vac
F 1 ≅ 100mA/1A/10A ac/dc	N 1~230 Vac
G PTC	O 1 A
H CosPhi	P 5 A
	Q 50/60 Hz 110... 400 Vac

Connecting voltage

1 Measuring circuit
2 24...240 Vac/dc
3 230 Vac

Load monitoring

EMR DP22H

Function description

When the supply voltage U is applied, the output relays switch into on-position (yellow LED R and LED I=0 illuminated) and the set interval of the start-up suppression (START) begins (green LED U flashes). Changes of the measured power factor ($\cos\phi$) during this period do not affect the state of the output relay. After the interval has expired the green LED is illuminated steadily.

For all the functions the LEDs MIN and MAX are flashing alternating, when the minimum value for the measured power factor was chosen to be greater than the maximum value.

Overload monitoring (OVER, OVER+LATCH)

When the measured power factor exceeds the value adjusted at the MAX-regulator, the set interval of the tripping delay (DELAY) begins (red LED MAX flashes). After the interval has expired (red LED MAX illuminated), the output relays switch into off-position (yellow LED R not illuminated). The output relays again switch into on-position (yellow LED R illuminated), when the measured power factor falls below the value adjusted at the MIN-regulator (red LED MAX not illuminated).

If the error memory is activated (OVER+LATCH) and the measured power factor remains above the MAX-value longer than the set interval of the tripping delay, the output relays remain in the off-position even if the measured power factor falls below the value adjusted at the MIN-regulator. After resetting the failure (interrupting and re-applying the supply voltage), the output relays switch into on-position and a new measuring cycle begins with the set interval of the start-up suppression (START).

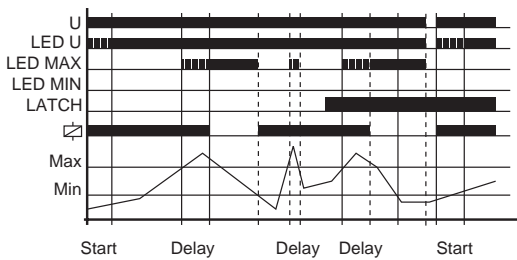

Underload monitoring (UNDER, UNDER+LATCH)

When the measured power factor falls below the value adjusted at the MIN-regulator, the set interval of the tripping delay (DELAY) begins (red LED MIN flashes). After the interval has expired (red LED MIN illuminated), the output relays switch into off-position (yellow LED R not illuminated). The output relays again switch into on-position (yellow LED R illuminated), when the measured power factor exceeds the value adjusted at the MAX-regulator (red LED MIN not illuminated).

If the error memory is activated (UNDER+LATCH) and the measured power factor remains below the MIN-value longer than the set interval of the tripping delay, the output relays remain in the off-position even if the measured power factor exceeds the value adjusted at the MAX-regulator. After resetting the failure (interrupting and re-applying the supply voltage), the output relays switch into on-position and a new measuring cycle begins with the set interval of the start-up suppression (START).

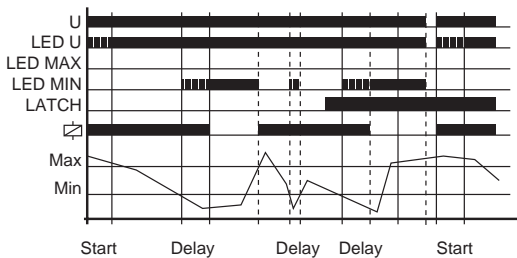

Window function (WIN, WIN+LATCH)

The output relays switch into on-position (yellow LED R illuminated) when the measured power factor exceeds the value adjusted at the MIN-regulator. When the measured power factor exceeds the value adjusted at the MAX-regulator, the set interval of the tripping delay (DELAY) begins (red LED MAX flashes). After the interval has expired (red LED MAX illuminated), the output relays switch into off-position (yellow LED R not illuminated). The output relays again switch into on-position (yellow LED R illuminated) when the measured power factor falls below the value adjusted at the MAX-regulator (red LED MAX not illuminated). When the measured power factor falls below the value adjusted at the MIN-regulator, the set interval of the tripping delay

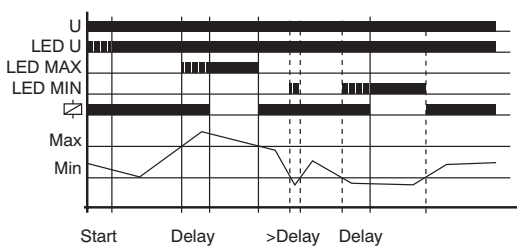

Load monitoring

EMR DP22H

(DELAY) begins again (red LED MIN flashes). After the interval has expired (red LED MIN illuminated), the output relays switch into off-position (yellow LED R not illuminated).

If the error memory is activated (WIN+LATCH) and the measured power factor remains below the MIN-value longer than the set interval of the tripping delay, the output relays remain in the off-position even if the measured power factor exceeds the value adjusted at the MIN-regulator. If the measured power factor remains above the MAX-value longer than the set interval of the tripping delay, the output relays remain in the off-position even if the measured power factor falls below the value adjusted at the MAX-regulator. After resetting the failure (interrupting and re-applying the supply voltage), the output relays switch into on-position and a new measuring cycle begins with the set interval of the start-up suppression (START).

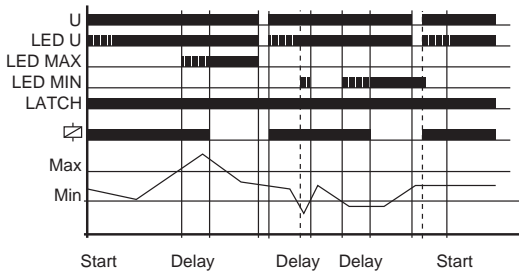

Recognition of disconnected consumers

When the current flow between L1i and L1k is interrupted for a time that is shorter than the minimum (< 100 ms) or set triggering delay, it is assumed that the consumer has been switched off deliberately and that no fault is present (yellow LED I=0 illuminated), output relays remain picked up (yellow LED R illuminated).

When the current flow is restored (consumer is switched back on), the measuring cycle is restarted with the set interval of the start-up suppression (START).

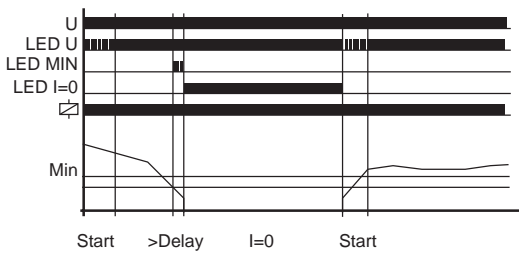

Connection

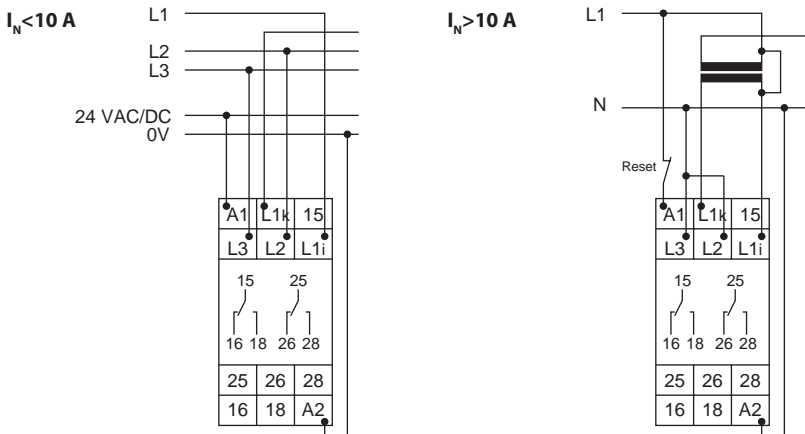

Dimensions

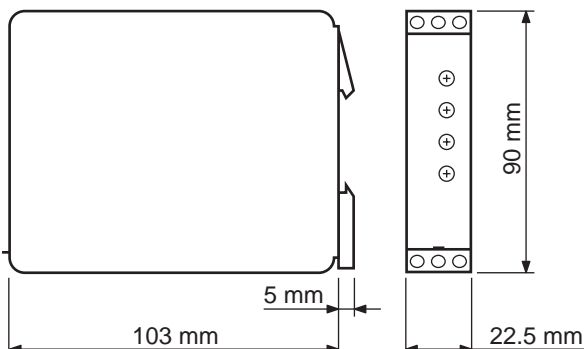

Frequency monitoring relay for 50/60 Hz power grids

EMR DF22Q



EMR DF22Q

- **Fault latch**
- **Power failure detection**
- **Measuring range 110 ... 400 Vac**
- **Windowifunction**
- **Adjustable thresholds**
- **2 changers**

Functions

Frequency monitoring for 50/60Hz power grids with adjustable thresholds, timing for ON-Delay and tripping delay separately adjustable and the following functions which are selected by means of rotary switch:

Nominal frequency 50Hz:

WIN 50Hz

- Monitoring the window between Min and Max

WIN+LATCH 50Hz

- Monitoring the window between Min and Max with fault latch

Nominal frequency 60Hz:

WIN 60Hz

- Monitoring the window between Min and Max

WIN+LATCH 60Hz

- Monitoring the window between Min and Max with fault latch

Time ranges

On-Delay:: Adjustment range 0 ... 10 s

Tripping delay: Adjustment range 0.1 ... 10 s

Indicators

Green LED ON: indication of supply voltage

Green LED flashes: indication of ON-Delay

Red LED Max/Min ON/OFF: indication of failure of the corresponding threshold

Red LED Max/Min flashes: indication of tripping delay of the corresponding threshold

Red LED UFailure ON/OFF: voltage failure

Yellow LED ON/OFF: indication of relay output

Output relay

2 potential free change-over contacts

Rated voltage: 250 Vac

Switching capacity: 750 VA (3A / 250 VAC)

- If the distance between the devices is less than 5mm!

Switching capacity: 1250 VA (5A / 250 VAC)

- If the distance between the devices is greater than 5mm!

Fusing: 5A fast acting

Connecting voltages

24 ... 240 Vac/dc, Terminals A1-A2 (galvanically separated)

Tolerance: 24 ... 240 Vdc, -20% ... +25% (galvanically separated)

24 ... 240 Vac, -15% ... +10% (galvanically separated)

100% duration of operation

Reference data

Selectron® EMR	Article no.
DF22Q 110 ... 400 Vac	41230040
(Order data see chapter 1)	

Frequency monitoring relay for 50/60 Hz power grids

EMR DF22Q

Technical data	
Nominal consumption	2 VA (1 W)
Nominal frequency	48 ... 400 Hz (24 ... 240 VAC)
	16 ... 48 Hz (48 ... 240 VAC)
Wave form for AC	Sinus
Ripple at dc	10%
Drop-out voltage	>15% of the supply voltage
Base accuracy	0.5% from F_N
Adjustment accuracy	—
Repetition accuracy	0.2% from F_N
Temperature influence	0,01% / °C
Recovery time	500 ms
Measuring circuit: Fusing	max. 20 A (according to UL 508)
Measured variable	Frequency, 1-phase (terminals E-F)
Voltage range	110 ... 400 VAC Sinus max. 300 VAC to earth
Tolerance	-15% ... +15%
Input resistance	1 MΩ
Switching threshold at $F_N = 50\text{Hz}$:	
Max:	49, 49.5, 50, 50.5, 51, 52, 53, 55, 57.5, 60 Hz
Min:	40, 42.5, 45, 47, 48, 49, 49.5, 50, 50.5, 51 Hz
Switching threshold at $F_N = 60\text{Hz}$:	
Max:	59, 59.5, 60, 60.5, 61, 62, 63, 65, 67.5, 70 Hz
Min:	50, 52.5, 55, 57, 58, 59, 59.5, 60, 60.5, 61 Hz
	The thresholds are adjustable by means of rotary switch (Max and Min)

Type key

EMR D F 2 2 Q ...

Construction

D Industrial design 22.5 mm
S pluggable 11 poles

Function

U Voltage
I Current
P CosPhi
T Temperature
S Star-Delta
F Frequency

Output

1 1 changer
2 2 changers
3 1 NC contact / 1 NO contact

Special functions

1 = Additional asymmetry monitoring

Measuring circuit

A No measuring circuit	I 12 Vdc
B 3(N)~115/66 Vac	J 24 Vdc
C 3(N)~230/132 Vac	K 36 Vdc
D 3(N)~400/230 Vac	L 48 Vdc
E 1 ≙ 30/60/300 Vac/dc	M 1~110 Vac
F 1 ≙ 100mA/1A/10A ac/dc	N 1~230 Vac
G PTC	O 1 A
H CosPhi	P 5 A
	Q 50/60 Hz 110... 400 Vac

Connecting voltage

1 Measuring circuit
2 24...240 Vac/dc
3 230 Vac

Frequency monitoring relay for 50/60 Hz power grids

EMR DF22Q

Function description

Window function (WIN, WIN+LATCH)

When the supply voltage U is applied, the set interval of the tripping delay (ON-Delay) begins. During this period and independent of the measured value the output relay R remains into off-position.

The output relay R switches into on-position after the set interval of the tripping delay (ON-Delay) has expired and if the frequency is within the adjusted window. As soon as the frequency leaves the accepted value the output relay R switches into off-position after the interval of the tripping delay (Delay) has expired

WIN

The output relay R switches into on-position again after the frequency re enters the accepted value and the tripping delay (ON-Delay) has expired.

WIN + LATCH

The output relay R switches only into on-position again by interrupting and re-applying the supply voltage, provided that the measured frequency is within the adjusted window after the interval of the tripping delay (ON-Delay) has expired.

Recognition of missing measuring voltage

If the measuring voltage is missing (red LED U_{Failure} illuminated) the output relay switches into off-position. When the measured voltage and frequency stays within the set limits for more than the ON-Delay the output relay energises.

If the fault latch is activated (WIN+LATCH) a detected frequency fault will not be reset by interrupting and re-applying the measuring voltage.

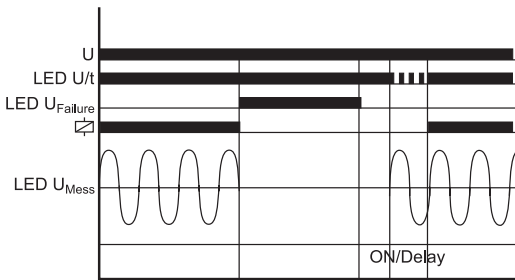
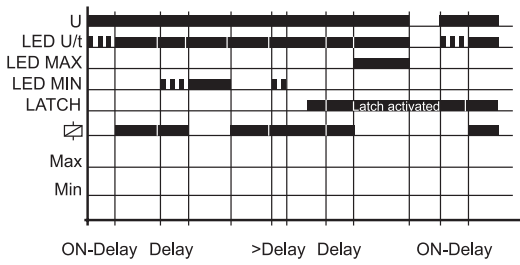

Frequency monitoring relay for 50/60 Hz power grids

EMR DF22Q

Connection

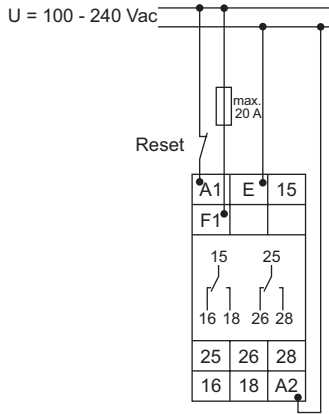

supply voltage = measuring voltage fault
latch activated

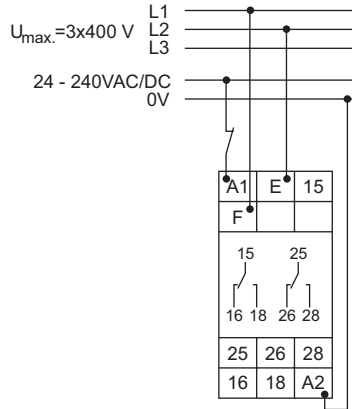

measuring voltage = 400 VAC
(phase-phase),
supply voltage = 24 - 240 VAC/DC fault
latch activated

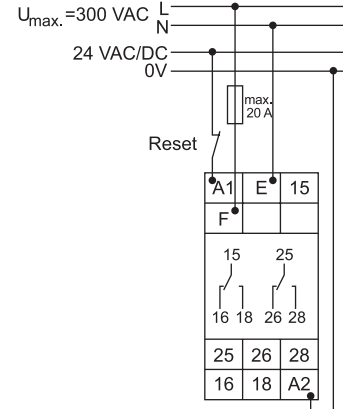

measuring voltage = 300 VAC,
supply voltage 24 VAC/DC fault
latch activated

Dimensions

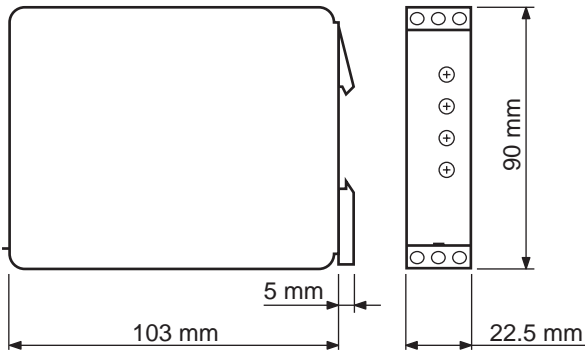

Accessories

Protection cover

Protection cover of self-extinguishing plastic material with spring catch to seal with lead for all devices of the EMR series for protection of inadvertent or unauthorized changes of setup parameters.

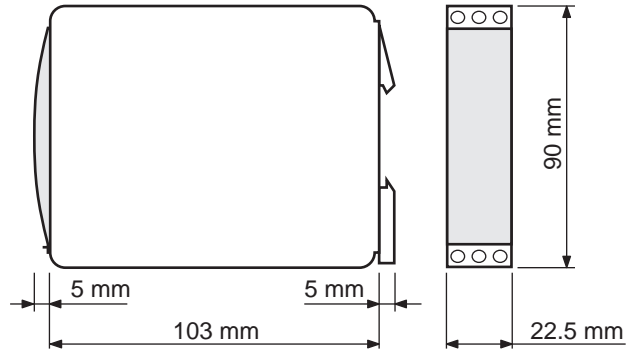

Description	Type	Weight	Article no
Protection cover for EMR (Order data see chapter 1)	SA 1	5 g	41230102

Mounting plate

The mounting-plate is used for the attachment of a DIN rail device on a mounting plate. Attachment by means of screws with 4 mm diameter.

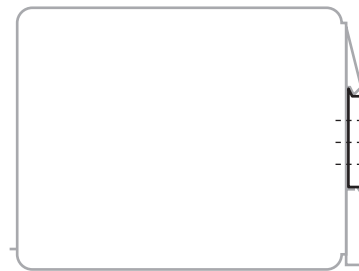

Description	Type	Weight	Article no
Mounting plate for EMR (Order data see chapter 1)	MP-1	5 g	41230101

Technical safety advice

This manual contains the information necessary for the correct utilisation of the products described therein. It is intended for technically qualified persons who are involved as either

- planning engineers familiar with the safety concepts of automation technology;
- or, operating personnel, who have been instructed in handling automation equipment and have a knowledge of the contents of this manual concerning operation;
- or, installation and servicing personnel possessing the necessary training to repair such an automation system or who have the authority to put such circuits and equipment/systems into operation, to earth or label them according to the relevant safety standards.

The products are constructed, manufactured and tested in compliance with the relevant VDE standards, VDE specifications and IEC recommendations.

Danger warning

These warnings serve both as a guide for those persons involved in a project and as safety advice to prevent damage to the products themselves or to associated equipment.

Due to advancements in technology, the wiring diagram on the actual device may be different than shown in this catalogue. In all instances where the actual device diagram is different, the wiring diagram on the device must be used when electrical connections are made.

Correct utilisation, configuration and assembly

The equipment is to be used only for the applications stated in the catalogue and technical literature, and only in conjunction with auxiliary equipment and devices that are recommended or approved by Selectron Systems Ltd.

Further, it should be noted that:

- the automation equipment must be disconnected from any power supply before it is assembled, disassembled or the configuration modified.
- Solid state electronic switches must not be tested with incandescent lamps or connected to a load that exceeds its rating.
- trouble-free and safe operation of the products requires correct transportation as well as appropriate storage, assembly and wiring.
- the systems may only be installed by trained personnel. In doing so, the relevant requirements contained in VDE 0100, VDE 0113, IEC 364, etc. must be complied with.

Prevention of material damage or personal injury

Additional external safety devices or facilities must be provided wherever significant material damage or even personal injury could result from a fault occurring in an automation system. A defined operating status must be ensured or forced by such devices or facilities (e.g. by independent limit switches, mechanical interlocks, etc.).

Advice concerning planning and installation of the products

- The safety and accident prevention measures applicable to a specific application are to be observed.
- In the case of mains-operated equipment, a check is to be made before putting it into operation to ensure that the preset mains voltage range is suitable for the local supply.
- In the case of a 24 V supply, care must be taken to ensure sufficient electrical insulation of the secondary side. Use only mains power supply units that conform to IEC 364-4-41 or HD 384.04.41 (VDE 0100 Part 410).
- Automation systems and their operating elements are to be installed in such a way that they are sufficiently protected against accidental operation.

Warranty

Selectron Systems Ltd. warrants its products to be free from defects in material and workmanship for a period of one year from the date of shipment. All claims under this warranty must be made within thirty (30) days of the discovery of the defect, and all defective products must be returned at the buyer's expense. Buyer's sole and exclusive right will be limited to, at the option of Selectron Systems Ltd., the repair or replacement by Selectron Systems Ltd., of any defective products for which a claim is made.

In all other matters please refer to the „General terms of business“ concerning Selectron Systems Ltd.

Note

The information given in this documentation corresponds to the state of development at the time of going to press and is therefore not binding. Selectron Systems Ltd. reserves the right to make alterations in the interests of technical advancement or product improvement at any time without giving reasons for doing so.

Prescriptions and standards

Mechanical data	
Housings in self-extinguishing plastic material. Protection mode IP 40	
Mounting: snapping mode:	Fixing on profile rail according DIN 46277/3 (EN 50 022)
Connection	via contact protected terminals up to 4 mm ² , protecting mode IP 20
Environmental conditions	
Admissible environmental temperatures from -25 °C ... +55 °C (corresponds IEC 68-1)	
Storage and transport temperature from -25 °C ... +70 °C	
Application class	IEC 721-3-3 (EN 60721-3-3)
Output relay	
Electrical lifetime:	230 Vac, min. 2x10 ⁵ switching cycles at 1000 VA ohmic load.
Mechanical lifetime:	min. 20 x 10 ⁶ switching cycles
Contact material	AgNi
Frequency range	48 ... 400 Hz / 24 ... 240 Vac, 16 ... 48 Hz / 24 ... 48 Vac
Duration of operation	100%
Protection	
Protection of the unit	5 A fast
Terminals	
Contact protection according VDE 0106 and VBG 4	
Terminal type:	sleeve with indirect screw pressure
Wire to connect:	rigid or flexible
Connecting limit:	4 mm ²
Terminal variants:	1 wire 0,5 mm ² ... 2,5 mm ² with/without wire end covers
	1 wire 4 mm ² without wire end covers
	2 wires 0,5 mm ² ... 1,5 mm ² with/without wire end covers
	2 wires 2,5 mm ² flexible without wire end covers
max. screw in torque:	1,0 Nm
Terminal screw for screw driver with PZ-1	
Insulation	
Isolation nominal voltage:	250 Vac (corresponds to IEC 60664-1)
Rating surge voltage:	4 kV, over-voltage category III, corresponds to IEC 60664-1
Electromagnetic compatibility	
Electrostatic discharge: Level 3, 6 kV contact, 8 kV air (corresponds to IEC 1000-4-2)	
High frequency electromagnetic fields: Level 3, 10 V/m (corresponds to IEC 1000-4-3)	
Fast transients: Level 4, 4 kV / 2,5 kHz, 5/50 ns (corresponds to IEC 1000-4-4)	
Lightning discharge: Level 3, 2 kV com., 1 kV dif., (corresponds to IEC 1000-4-5)	
Cable running disturbances induced by HF fields: Level 3, 10 V RMS (corresponds to IEC 1000-4-6)	
Spurious radiation net and aerial network: Class B (corresponds to CISPR 22)	
Prescriptions	
Air and leakage paces:	VDE 0110iGr. C/250
Test voltage:	VDE 0435 2000Vac
Low voltage directions according to IEC 664-1	
EMC emissions:	EN 50 081-1 and EN 55 022 class B
EMC interference stability:	Voltage impact strength according to IEC 1000-4-5
Burst:	EN 50 082-2, EN 61 812-1 (level 3)
ESD:	IEC 1000-4-2
HF over metallic circuits:	EN 50 082-2, ENPr 50141
Electro magnetic HF field according to EN 50 082-2, ENPr 50140 and ENPr 50204	
Production standard:	according to ISO 9001

Monitoring relay

Content

Monitoring relay mounting position

1-phase current monitoring relay	
EMR IU11Q	2
Technical data.....	3
Function description	4
Connection	5
1-phase ac/dc voltage monitoring relay	
EMR IU11N	6
Technical data.....	7
Function description	8
Connection	9
3-phase voltage monitoring relay	
EMR IU11D1, IU21D1	10
Technical data.....	11
Function description	12
Connection	13
1-phase or 3-phase voltage monitoring relay (Multifunction)	
EMR IU11D	14
Technical data.....	15
Function description	16
Connection	17
Temperature monitoring relay	
EMR IT13G	18
Technical data.....	19
Function description	20
Connection	21
Technical safety advice	22
Prescriptions and standards	23

Edition 02.09

Subject to technical changes and amendments to technical specifications at any time

1-phase current monitoring relay

EMR II11Q



EMR II11Q

- **ac current monitoring in 1-phase mains**
- **Measuring range 10 A ac**
- **Multifunction**
- **Error Memory (Latch)**
- **1 change-over contact**

Functions

ac current monitoring in 1-phase mains with adjustable thresholds, tripping delay adjustable and the following functions selectable by means of rotary switch

- Overcurrent monitoring
- Overcurrent monitoring with error memory
- Undercurrent monitoring
- Undercurrent monitoring with error memory
- Monitoring the window between Min and Max
- Monitoring the window between Min and Max with error memory

Time ranges

Tripping delay: Adjustment range 0.1 ... 10 s

Indicators

Green LED ON: indication of supply voltage
Yellow LED ON/OFF: indication of relay output
Red LED ON/OFF: indication of failure of the corresponding threshold
Red LED flashing: indication of tripping delay of the corresponding threshold

Output relay

1 potential free change-over contact
Rated voltage: 250 Vac
Switching capacity: 1250 VA (5 A / 250 Vac)
Fusing: 5 A fast acting

Connecting voltages

230 Vac, -15% ... +15% of U_N
100% duration of operation

Reference data

Selectron® EMR	Article no.
EMR II11Q 10 A	41230033
(Order data see chapter 1)	

1-phase current monitoring relay

EMR II11Q

Technical data	
Nominal consumption	5 VA / 0.8 W
Nominal frequency	48 ... 63 Hz
Wave form ac	sine
Drop-out voltage	>20% of the supply voltage
Base accuracy	±5% (of maximum nominal value)
Adjustment accuracy	±5% (of maximum nominal value)
Repetition accuracy	≤2% (of maximum nominal value)
Temperature influence	0.05% / °C
Recovery time	500 ms
Measuring circuit: Input:	
10 A ac	terminals Li and Lk
Overload capacity:	13 A (from 10 A - distance > 5 mm)
Input resistance:	3 mΩ
Inrush current:	
1s	100 A
3s	50 A
Switching threshold:	
Max:	10% ... 100% of I_N
Min:	5% ... 95% of I_N

Type key

EMR I I 1 1 Q ...																			
Construction	Special functions																		
D Industrial design 22.5 mm S pluggable 11 poles I Mounting position 22.5/35 mm	1 = Additional asymmetry monitoring																		
Function	Measuring circuit																		
U Voltage I Current P CosPhi T Temperature S Star-Delta	<table border="0"> <tr> <td>A No measuring circuit</td> <td>I 12 Vdc</td> </tr> <tr> <td>B 3(N)~115/66 Vac</td> <td>J 24 Vdc</td> </tr> <tr> <td>C 3(N)~230/132 Vac</td> <td>K 36 Vdc</td> </tr> <tr> <td>D 3(N)~400/230 Vac</td> <td>L 48 Vdc</td> </tr> <tr> <td>E 1 ≅ 30/60/300 Vac/dc</td> <td>M 1~110 Vac</td> </tr> <tr> <td>F 1 ≅ 100mA/1A/10A ac/dc</td> <td>N 1~230 Vac</td> </tr> <tr> <td>G PTC</td> <td>O 1 A</td> </tr> <tr> <td>H CosPhi</td> <td>P 5 A</td> </tr> <tr> <td></td> <td>Q 10 A</td> </tr> </table>	A No measuring circuit	I 12 Vdc	B 3(N)~115/66 Vac	J 24 Vdc	C 3(N)~230/132 Vac	K 36 Vdc	D 3(N)~400/230 Vac	L 48 Vdc	E 1 ≅ 30/60/300 Vac/dc	M 1~110 Vac	F 1 ≅ 100mA/1A/10A ac/dc	N 1~230 Vac	G PTC	O 1 A	H CosPhi	P 5 A		Q 10 A
A No measuring circuit	I 12 Vdc																		
B 3(N)~115/66 Vac	J 24 Vdc																		
C 3(N)~230/132 Vac	K 36 Vdc																		
D 3(N)~400/230 Vac	L 48 Vdc																		
E 1 ≅ 30/60/300 Vac/dc	M 1~110 Vac																		
F 1 ≅ 100mA/1A/10A ac/dc	N 1~230 Vac																		
G PTC	O 1 A																		
H CosPhi	P 5 A																		
	Q 10 A																		
Output	Connecting voltage																		
1 1 changer 2 2 changers 3 1 NC contact / 1 NO contact	1 Measuring circuit 2 24...240 Vac/dc 3 230 Vac																		

1-phase current monitoring relay

EMR II11Q

Function description

Overcurrent monitoring (OVER, OVER+LATCH)

When the supply voltage U is applied, the output relays R switches into on-position if the measured current is below the MAX-value.

When the measured current exceeds the MAX-value, the output relay R switches into off-position after the interval of the tripping delay (DELAY) has expired.

The output relay R switches into on-position again, if the current falls below the MIN-value (OVER).

The output relay R switches only into on-position again by interrupting and re-applying of the supply voltage, provided that the measured current is below the MAX-value (OVER+LATCH).

Undercurrent monitoring (UNDER, UNDER+LATCH)

When the supply voltage U is applied, the output relay R switches into on-position, if the measured current is beyond the MIN-value.

When the measured current falls below the MIN-value, the output relay R switches into off-position after the interval of the tripping delay (DELAY) has expired.

The output relay R switches into on-position again, if the current exceeds the MAX-value (UNDER).

The output relay R switches only into on-position again by interrupting and re-applying of the supply voltage, provided that the measured current is beyond the MIN-value (UNDER+LATCH).

Window function (WIN, WIN+LATCH)

When the supply voltage U is applied, the output relay R switches into on-position, if the measured current is within the adjusted window.

When the measured current leaves the window between MIN and MAX, the output relay R switches into off-position after the interval of the tripping delay (DELAY) has expired.

The output relay R switches into on-position again, if the current re-enter the adjusted window (WIN).

The output relay R switches only into on-position again by interrupting and re-applying of the supply voltage, provided that the measured current is within the threshold values (WIN+LATCH).

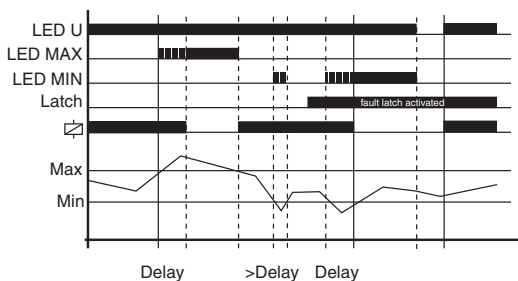
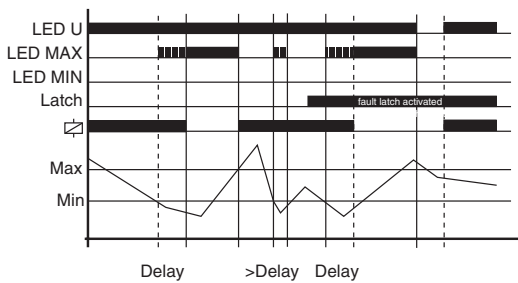
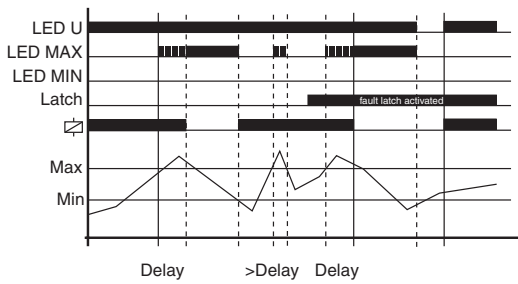

1-phase current monitoring relay

EMR II11Q

Connection

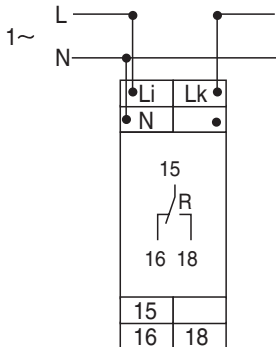

Load limit curves

EMR II11Q

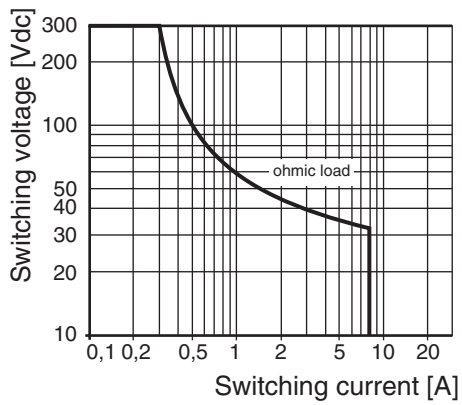

Dimensions

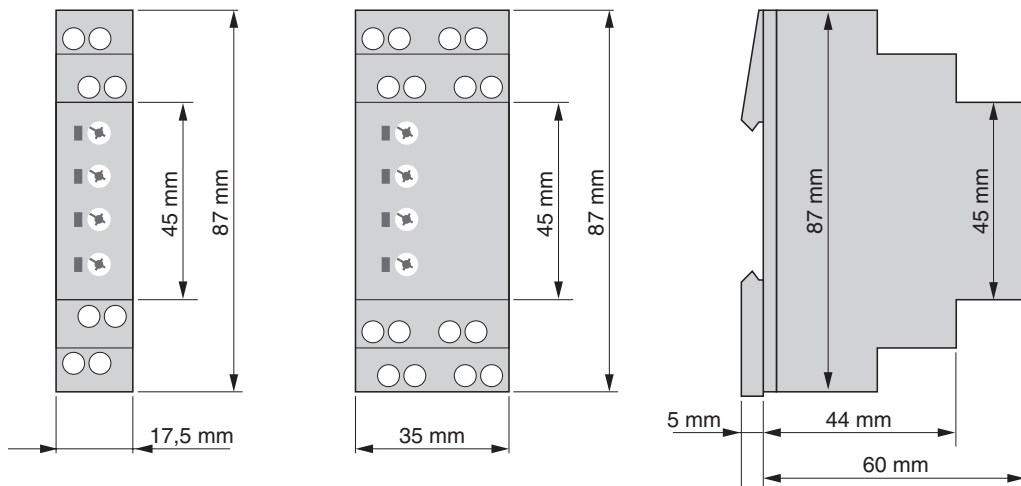

1-phase ac/dc voltage monitoring relay

EMR IU11N



IU11N

- **ad/dc voltage monitoring in 1-phase mains**
- **Measuring range 24Vac/dc, 230 Vac**
- **Multifunction**
- **1 change-over contact**

Functions

ac/dc voltage monitoring in 1-phase mains with adjustable thresholds and the following functions which are selectable by means of rotary switch

- Undervoltage monitoring
- Monitoring the window between Min and Max

Indicators

Green LED ON: indication of supply voltage
Yellow LED ON/OFF: indication of relay output
Red LED ON/OFF: indication of failure of the corresponding threshold

Output relay

1 potential free change-over contact
Rated voltage: 250 Vac
Switching capacity: 1250 VA (5 A / 250 Vac)
Fusing: 5A fast acting

Connecting voltages

24 Vdc, 24 Vac, 230 Vac (= Measuring voltage)
-25% ... +20% of U_N
100% duration of operation

Reference data

Selectron® EMR	Article no.
IU11N	41230034
(Order data see chapter 1)	

1-phase ac/dc current monitoring relay

EMR IU11N

Technical data		
Nominal consumption	24 Vdc	0.6 W
	24 Vac	1.3 VA / 0.8 W
	230 Vac	10 VA / 0.6 W
Nominal frequency ac		48 ... 63 Hz
Ripple at dc		10%
Drop-out voltage		according to switching threshold
Base accuracy		±5% (of maximum nominal value)
Adjustment accuracy		±5% (of maximum nominal value)
Repetition accuracy		≤2% (of maximum nominal value)
Temperature influence		0.05% / °C
Recovery time		500 ms
Measuring circuit: Input:		
	24 Vdc	E and F1 (+)
	24 Vac	E and F2 (distance > 5 mm)
	230 Vac	E and F3
Overload capacity:		120% of U _N
Input resistance:		according to nominal voltage 0.8 W
Switching threshold:		
	Max:	80% ... 120% of U _N
	Min:	75% ... 115% of U _N

Type key

EMR I U 1 1 N ...																			
<p>Construction</p> <p>D Industrial design 22.5 mm</p> <p>S pluggable 11 poles</p> <p>I Mounting position 22.5/35 mm</p>	<p>Special functions</p> <p>1 = Additional asymmetry monitoring</p>																		
<p>Function</p> <p>U Voltage</p> <p>I Current</p> <p>P CosPhi</p> <p>T Temperature</p> <p>S Star-Delta</p>	<p>Measuring circuit</p> <table border="0"> <tr> <td>A No measuring circuit</td> <td>I 12 Vdc</td> </tr> <tr> <td>B 3(N)~115/66 Vac</td> <td>J 24 Vdc</td> </tr> <tr> <td>C 3(N)~230/132 Vac</td> <td>K 36 Vdc</td> </tr> <tr> <td>D 3(N)~400/230 Vac</td> <td>L 48 Vdc</td> </tr> <tr> <td>E 1 ≅ 30/60/300 Vac/dc</td> <td>M 1~110 Vac</td> </tr> <tr> <td>F 1 ≅ 100mA/1A/10A ac/dc</td> <td>N 1~230 Vac</td> </tr> <tr> <td>G PTC</td> <td>O 1 A</td> </tr> <tr> <td>H CosPhi</td> <td>P 5 A</td> </tr> <tr> <td></td> <td>Q 10 A</td> </tr> </table>	A No measuring circuit	I 12 Vdc	B 3(N)~115/66 Vac	J 24 Vdc	C 3(N)~230/132 Vac	K 36 Vdc	D 3(N)~400/230 Vac	L 48 Vdc	E 1 ≅ 30/60/300 Vac/dc	M 1~110 Vac	F 1 ≅ 100mA/1A/10A ac/dc	N 1~230 Vac	G PTC	O 1 A	H CosPhi	P 5 A		Q 10 A
A No measuring circuit	I 12 Vdc																		
B 3(N)~115/66 Vac	J 24 Vdc																		
C 3(N)~230/132 Vac	K 36 Vdc																		
D 3(N)~400/230 Vac	L 48 Vdc																		
E 1 ≅ 30/60/300 Vac/dc	M 1~110 Vac																		
F 1 ≅ 100mA/1A/10A ac/dc	N 1~230 Vac																		
G PTC	O 1 A																		
H CosPhi	P 5 A																		
	Q 10 A																		
<p>Output</p> <p>1 1 changer</p> <p>2 2 changers</p> <p>3 1 NC contact / 1 NO contact</p>	<p>Connecting voltage</p> <p>1 Measuring circuit</p> <p>2 24...240 Vac/dc</p> <p>3 230 Vac</p>																		

1-phase ac/dc voltage monitoring relay

EMR IU11N

Function description

Under voltage monitoring (UNDER)

When the supply voltage U is applied, the output relay R switches into on-position, if the measured voltage is beyond the MIN-value.

When the measured voltage falls below the MIN-value, the output relay R switches into off-position. The output relay R switches into on-position again, if the voltage exceeds the MAX-value.

Window function (WIN)

When the supply voltage U is applied, the output relay R switches into on-position, if the measured voltage is within the adjusted window. When the measured voltage left the window between MIN and MAX, the output relay R switches into off-position. The output relay R switches into on-position again, if the voltage re-enter the adjusted window.

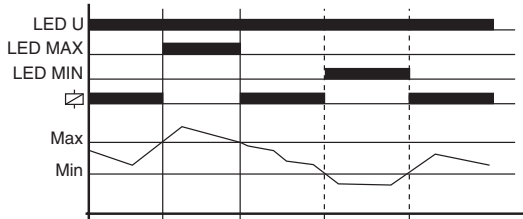
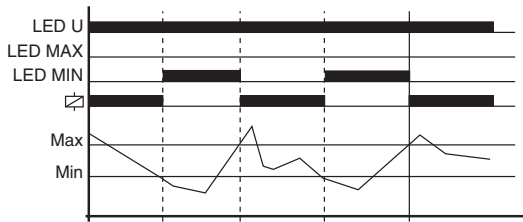

1-phase ac/dc voltage monitoring relay

EMR IU11N

Connection

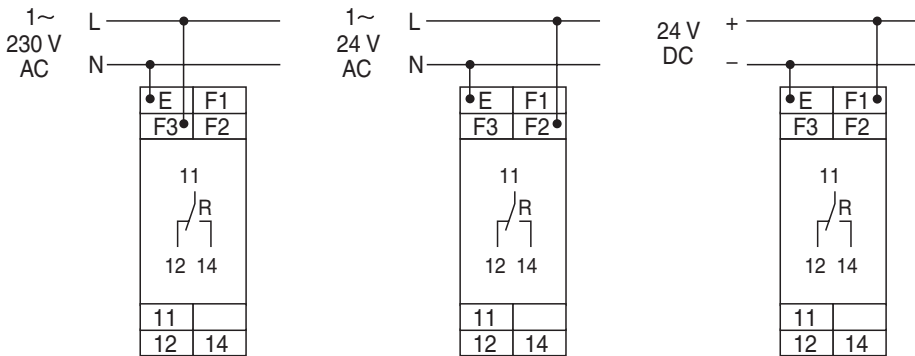

Load limit curves

EMR IU11N

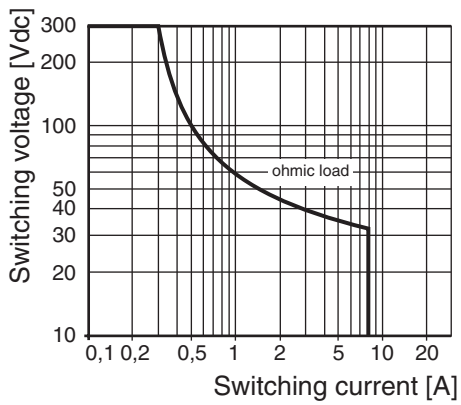

Dimensions

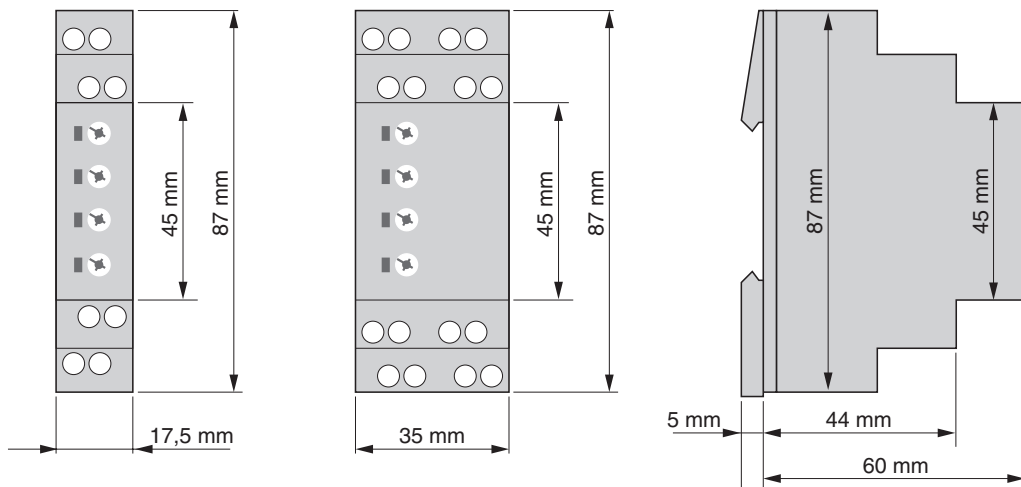

3-phase voltage monitoring relay

EMR IU11D1, IU21D1



EMR IU11D1

- Voltage monitoring in 3-phase mains
- Measuring range 400/230 Vac 3Ph
- Monitoring of phase sequence and phase failure
- Monitoring of asymmetry
- Connection of neutral wire optional
- 1 or 2 change-over contacts

Functions

Monitoring of phase sequence, phase failure and monitoring of asymmetry with adjustable asymmetry.

Indicators

Green LED ON: indication of supply voltage

Yellow LED ON/OFF: indication of relay output

Output relay

1 or 2 potential free change-over contact(s)

Rated voltage: 250 Vac

Switching capacity: 1250 VA (5 A / 250 Vac)

Fusing: 5A fast acting



EMR IU21D1

Connecting voltages

3(N) ~400/230 V, Terminals (N)-L1-L2-L3 (= supply voltage)

-30% ... +30% of U_N

100% duration of operation

Reference data

Selectron® EMR	Article no.
IU11D1	41230030
IU21D1	41230031
(Order data see chapter 1)	

3-phase voltage monitoring relay

EMR IU11D1, IU21D1

Technical data		
Nominal consumption	EMR IU11D1	3(N) ~400/230 V, 8 VA / 0.8 W
	EMR IU21D1	3(N) ~400/230 V, 11 VA / 1.2 W
Nominal frequency		48 ... 63 Hz
Drop-out voltage		>20% of the supply voltage
Base accuracy		±5%
Adjustment accuracy		≤5%
Repetition accuracy		±2%
Temperature influence		≤0.05% / °C
Recovery time		fixed, approx. 100 ms
Recovery time		500 ms
Measuring circuit: Input:		
	3(N) ~400/230 V	terminals (N)-L1-L2-L3 (= supply voltage)
Overload capacity:		
	3(N) ~400/230 V	-30% ... +30%
Input resistance:		
	3(N) ~400/230 V	according to nominal voltage 8 VA / 0.8 W for EMR IU11D1 according to nominal voltage 11 VA / 1.2 W for EMR IU21D1
Asymmetry:		5% ... 25%

Type key

EMR I U 1 1 D 1	
Construction	Special functions
D Industrial design 22.5 mm	1 = Additional asymmetry monitoring
S pluggable 11 poles	
I Mounting position 22.5/35 mm	
Function	Measuring circuit
U Voltage	A No measuring circuit
I Current	B 3(N)~115/66 Vac
P CosPhi	C 3(N)~230/132 Vac
T Temperature	D 3(N)~400/230 Vac
S Star-Delta	E 1 ≅ 30/60/300 Vac/dc
	F 1 ≅ 100mA/1A/10A ac/dc
	G PTC
	H CosPhi
	I 12 Vdc
	J 24 Vdc
	K 36 Vdc
	L 48 Vdc
	M 1~110 Vac
	N 1~230 Vac
	O 1 A
	P 5 A
	Q 10 A
Output	Connecting voltage
1 1 changer	1 Measuring circuit
2 2 changers	2 24...240 Vac/dc
3 1 NC contact / 1 NO contact	3 230 Vac

3-phase voltage monitoring relay

EMR IU11D1, IU21D1

Function description

Phase sequence monitoring

When all the phases are connected in the correct sequence and the measured asymmetry is less than the fixed value, the output relay switches into on-position (yellow LED illuminated). When the phase sequence changes, the output relay switches into off-position (yellow LED not illuminated).

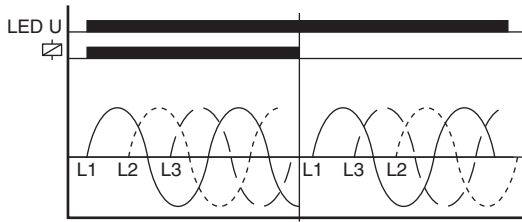

Phase failure monitoring

The output relay switches into off-position (yellow LED not illuminated), when one of the three phases fails.

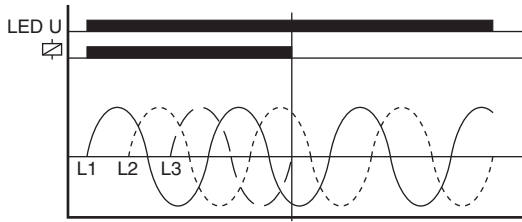

Asymmetry monitoring

The output relay R switches into off-position (yellow LED not illuminated) when the asymmetry exceeds the value set at the ASYM-regulator.

Reverse voltages of a consumer (e.g. a motor which continues to run on two phases only) do not effect the disconnection.

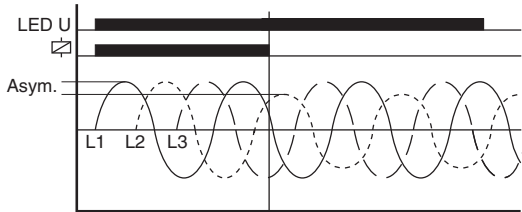

3-phase voltage monitoring relay

EMR IU11D1, IU21D1

Connection

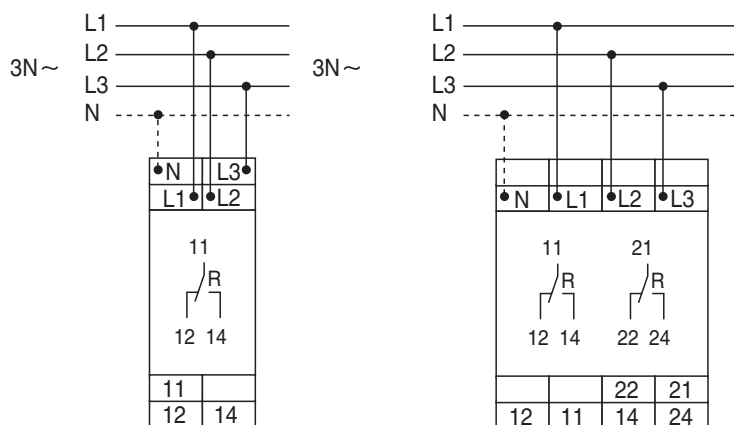

Load limit curves

EMR IU11D1

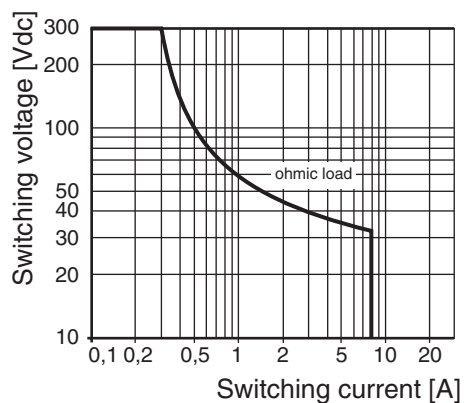

EMR IU21D1

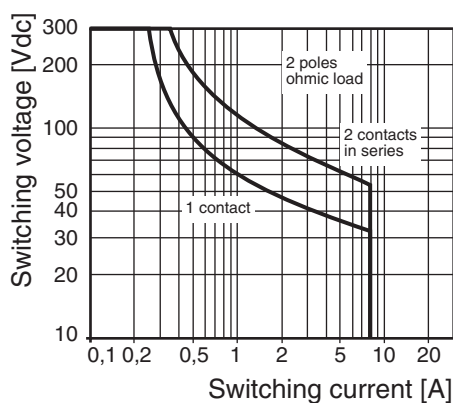

Dimensions

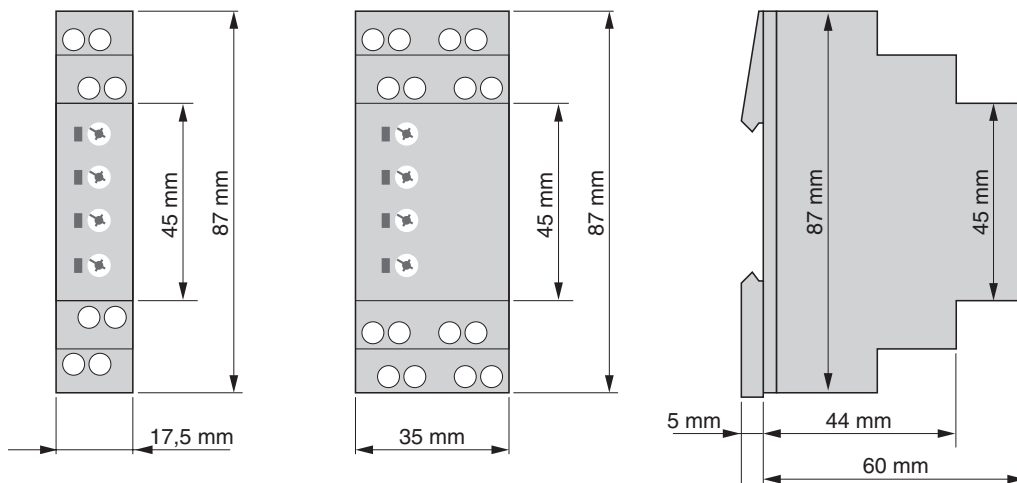

1-phase or 3-phase voltage monitoring relay (Multifunction)

EMR IU11D



EMR IU11D

- **Voltage monitoring in 3-phase mains**
- **Measuring range 400/230 Vac 3Ph / 230 V 1Ph**
- **Multifunction**
- **Monitoring of phase sequence and phase failure**
- **Connection of neutral wire optional**
- **1 change-over contact**

Functions

Voltage monitoring in 1-phase and 3-phase mains with adjustable thresholds, adjustable tripping delay, monitoring of phase sequence and phase failure and the following functions which are selectable by means of rotary switch.

- Undervoltage monitoring
- Undervoltage monitoring and monitoring of phase sequence
- Monitoring of window between Min and Max
- Monitoring the window between Min and Max and monitoring of phase sequence.

Time ranges

Start-up suppression time:-

Tripping delay: Adjustment range 0.1 ... 10 s

Indicators

- Red LED ON/OFF: indication of failure of the corresponding threshold
- Red LED flashes: indication of tripping delay of the corresponding threshold
- Yellow LED ON/OFF: indication of relay output

Output relay

- 1 potential free change-over contact
- Rated voltage: 250 Vac
- Switching capacity: 1250 VA (5 A / 250 Vac)
- Fusing: 5A fast acting

Connecting voltages

- 1(N) ~ 230 V, terminals (N)-L1-L2-L3 (= Measuring voltage)
- 3(N) ~ 400/230 V, terminals (N)-L1-L2-L3 (= Measuring voltage)
- 30% ... +30% of U_N
- 100% duration of operation

Reference data

Selectron® EMR	Article no.
IU11D	41230032
(Order data see chapter 1)	

1-phase or 3-phase voltage monitoring relay (Multifunction)

EMR IU11D

Technical data	
Nominal consumption	3(N) ~400/230 V, 8 VA / 1 W
Nominal frequency	48 ... 63 Hz
Drop-out voltage	>20% of the supply voltage
Base accuracy	±5% (of scale limit)
Adjustment accuracy	±5% (of scale limit)
Repetition accuracy	≤2%
Temperature influence	≤1% / °C
Recovery time	500 ms
Measuring circuit: Input:	
	3(N) ~230/400 V Terminals (N)-L1-L2-L3
Overload capacity:	
	3(N) ~230/400 V -30% ... +30%
Input resistance:	
	3(N) ~230/400 V according to nominal voltage 8 VA / 1 W
Switching threshold:	
Max:	80% ... 130% of U_N
Min:	70% ... 120% of U_N

Type key

EMR I U 1 1 D ...	
Construction	Special functions
D Industrial design 22.5 mm	1 = Additional asymmetry monitoring
S pluggable 11 poles	
I Mounting position 22.5/35 mm	
Function	Measuring circuit
U Voltage	A No measuring circuit
I Current	B 3(N)~115/66 Vac
P CosPhi	C 3(N)~230/132 Vac
T Temperature	D 3(N)~400/230 Vac
S Star-Delta	E 1 ≅ 30/60/300 Vac/dc
	F 1 ≅ 100mA/1A/10A ac/dc
	G PTC
	H CosPhi
	I 12 Vdc
	J 24 Vdc
	K 36 Vdc
	L 48 Vdc
	M 1~110 Vac
	N 1~230 Vac
	O 1 A
	P 5 A
	Q 10 A
Output	Connecting voltage
1 1 changer	1 Measuring circuit
2 2 changers	2 24...240 Vac/dc
3 1 NC contact / 1 NO contact	3 230 Vac

1-phase or 3-phase voltage monitoring relay (Multifunction)

EMR IU11D

Function description

For all the functions the LEDs MIN and MAX are flashing alternating (the relay is fallen off), when the minimum value for the measured voltage was chosen to be greater than the maximum value.

If a failure already exists when the device is activated, the output relay remain in off-position and the LED for the corresponding threshold is illuminated.

The device includes separately every phase voltage (L-N) and monitors it according to the selected function (UNDER or WINDOW).

Undervoltage monitoring (UNDER, UNDER+SEQ)

When the measured voltage (one of the phase voltages) falls below the value adjusted at the MIN-regulator, the set interval of the tripping delay (DELAY) begins (red LED MIN flashes). After the interval has expired (red LED MIN illuminated), the output relay R switches into off-position (yellow LED not illuminated). The output relay R switches into on-position (yellow LED illuminated), when the measured voltage (all phase voltages) exceeds the value adjusted at the MAX-regulator.

Window function (WIN, WIN+SEQ)

The output relay R switches into on-position (yellow LED illuminated) when the measured voltage (all phase voltages) exceeds the value adjusted at the MIN-regulator. When the measured voltage (one of the phase voltages) exceeds the value adjusted at the MAX-regulator, the set interval of the tripping delay (DELAY) begins (red LED MAX flashes). After the interval has expired (red LED MAX illuminated) the output relay R switches into off-position (yellow LED not illuminated). The output relay R switches into on-position again (yellow LED illuminated) when the measured voltage falls below the value adjusted at the MAX-regulator (red LED MAX not illuminated). When the measured voltage (one of the phase voltage) falls below the value adjusted at the MIN-regulator, the set interval of the tripping delay (DELAY) begins again (red LED MIN flashes). After the interval has expired (red LED MIN illuminated), the output relay R switches into off-position (yellow LED not illuminated).

Phase sequence monitoring (SEQ)

Phase sequence monitoring is selectable for all functions.

In single phase circuit, the phase sequence monitoring must be disconnected.

If a change in phase sequence is detected (red LED SEQ illuminated), the output relay R switches into off-position after the set interval of tripping delay (DELAY) has expired (yellow LED not illuminated).

Neutral wire break

The device monitors every phase (L1, L2 and L3) against the neutral wire N. A shift of neutral point occurs by an asymmetrical phase load if the neutral wire breaks in the power line.

If one of the phase voltages exceeds the value adjusted at the trip point, the set interval of tripping delay (DELAY) begins (red LED MIN or MAX flashes). After the interval has expired (red LED MIN or MAX illuminated), the output relay switches into off-position (yellow LED not illuminated).

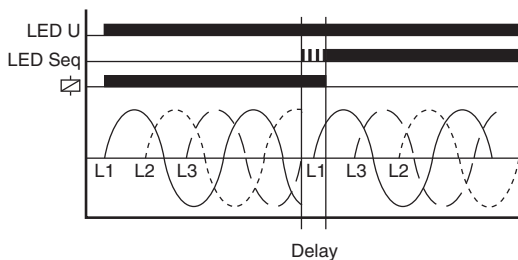
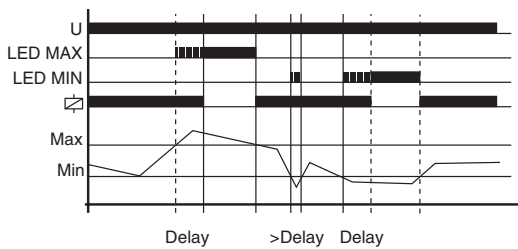
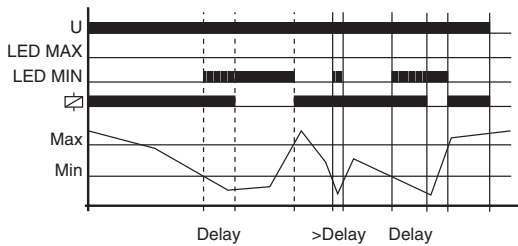

Shift of neutral point caused by asymmetrical phase load and missing neutral wire

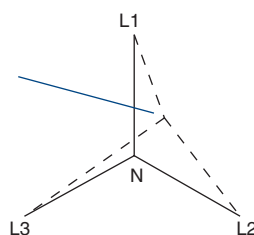

1-phase or 3-phase voltage monitoring relay (Multifunction)

EMR IU11D

Connection

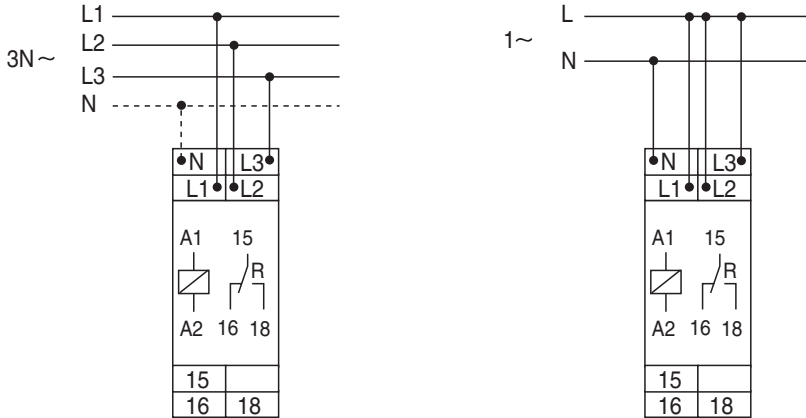

Load limit curves

EMR IU11D

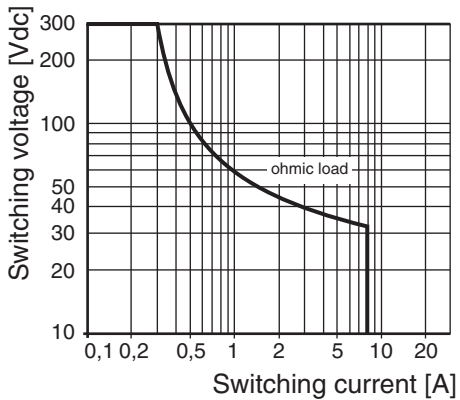

Dimensions

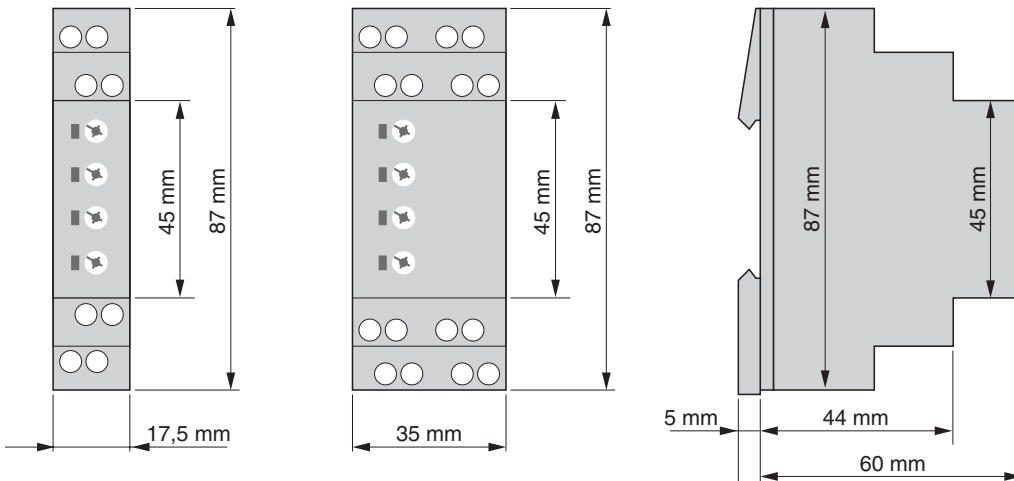

Temperature monitoring relay

EMR IT13G



EMR IT13G

- **Temperature monitoring of the motor winding**
- **1 changer**
- **External reset key connectable**

Functiones

Temperature monitoring of the motor winding (max. 6 PTC) with fault latch, for temperature probes in accordance with DIN 44081. Short circuit monitoring of the thermistor line (selectable by means of terminals). Test function with integrated test/reset key.

Indicators

Green LED ON: indication of supply voltage
Red LED ON/OFF: indication of failure

Output relay

1 potential free change-over contact
Rated voltage: 250 Vac
Switching capacity: 1250 VA (5 A / 250 Vac)
Fusing: 5A fast acting

Connecting voltages

230 Vac, Terminals A1-A2
-15% ... +10%
100% duration of operation

Reference data

Selectron® EMR	Article no.
IT13G 230 Vac (Order data see chapter 1)	41230035

Temperature monitoring relay

EMR IT13G

Technical data	
Nominal consumption	1.3 VA / 1 W
Nominal frequency	48 ... 63 Hz
Drop-out voltage	>30% of the supply voltage
Base accuracy	±5% (of maximum scale value)
Repetition accuracy	≤1%
Temperature influence	≤0.15% / °C
Measuring circuit: T	terminals T1-T2 or T1-T3
Initial resistance	<1.5 kΩ
Response value (relay in off-position)	≥3.6 kΩ
Release value (relay in on-position)	≤1.65 kΩ
Disconnection (short circuit thermistor)	yes at T1-T2, no at T1-T3
Measuring voltage T1-T2	≤7.5 Vdc at R ≤4.0 kΩ (according to EN 60947-8)
Line length R1-R2	max. 10 m (twisted pair)
Control pulse length	min. 50 ms

Type key

EMR I T 1 3 G ...																			
<p>Construction</p> <p>D Industrial design 22.5 mm</p> <p>S pluggable 11 poles</p> <p>I Mounting position 22.5/35 mm</p> <p>Function</p> <p>U Voltage</p> <p>I Current</p> <p>P CosPhi</p> <p>T Temperature</p> <p>S Star-Delta</p> <p>Output</p> <p>1 1 changer</p> <p>2 2 changers</p> <p>3 1 NC contact / 1 NO contact</p>	<p>Special functions</p> <p>1 = Additional asymmetry monitoring</p> <p>Measuring circuit</p> <table border="0"> <tr> <td>A No measuring circuit</td> <td>I 12 Vdc</td> </tr> <tr> <td>B 3(N)~115/66 Vac</td> <td>J 24 Vdc</td> </tr> <tr> <td>C 3(N)~230/132 Vac</td> <td>K 36 Vdc</td> </tr> <tr> <td>D 3(N)~400/230 Vac</td> <td>L 48 Vdc</td> </tr> <tr> <td>E 1 ≅ 30/60/300 Vac/dc</td> <td>M 1~110 Vac</td> </tr> <tr> <td>F 1 ≅ 100mA/1A/10A ac/dc</td> <td>N 1~230 Vac</td> </tr> <tr> <td>G PTC</td> <td>O 1 A</td> </tr> <tr> <td>H CosPhi</td> <td>P 5 A</td> </tr> <tr> <td></td> <td>Q 10 A</td> </tr> </table> <p>Connecting voltage</p> <p>1 Measuring circuit</p> <p>2 24...240 Vac/dc</p> <p>3 230 Vac</p>	A No measuring circuit	I 12 Vdc	B 3(N)~115/66 Vac	J 24 Vdc	C 3(N)~230/132 Vac	K 36 Vdc	D 3(N)~400/230 Vac	L 48 Vdc	E 1 ≅ 30/60/300 Vac/dc	M 1~110 Vac	F 1 ≅ 100mA/1A/10A ac/dc	N 1~230 Vac	G PTC	O 1 A	H CosPhi	P 5 A		Q 10 A
A No measuring circuit	I 12 Vdc																		
B 3(N)~115/66 Vac	J 24 Vdc																		
C 3(N)~230/132 Vac	K 36 Vdc																		
D 3(N)~400/230 Vac	L 48 Vdc																		
E 1 ≅ 30/60/300 Vac/dc	M 1~110 Vac																		
F 1 ≅ 100mA/1A/10A ac/dc	N 1~230 Vac																		
G PTC	O 1 A																		
H CosPhi	P 5 A																		
	Q 10 A																		

Temperature monitoring relay

EMR IT13G

Function description

Temperature monitoring of the motor winding with fault latch

If the supply voltage is applied (green LED illuminated) and the cumulative resistance of the PTC-circuit is less than $3.6\text{k}\Omega$ (standard temperature of the motor), the output relay R switches into on-position.

Pressing the test/reset key under this conditions forces the output relay to switch into off-position. It remains in state as long as the test/reset key is pressed and thus the switching function can be checked in case of fault. The test function is not effective by using an external reset key.

When the cumulative resistance of the PTC-circuit exceeds $3.6\text{k}\Omega$ (at least one of the PTCs has reached the cut-off temperature), the output relay switches into off-position (red LED illuminated).

The output relay R switches into on-position again (red LED not illuminated), if the cumulative resistance drops below $1.65\text{k}\Omega$ by cooling down of the PTC and either a reset key (internal or external) was pressed or the supply voltage was disconnected and reapplied.

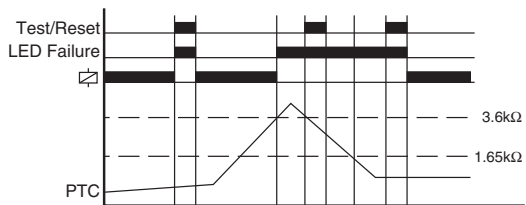
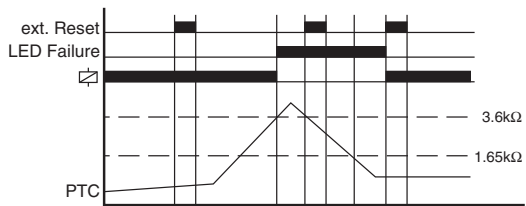

Temperature monitoring relay

EMR IT13G

Connection

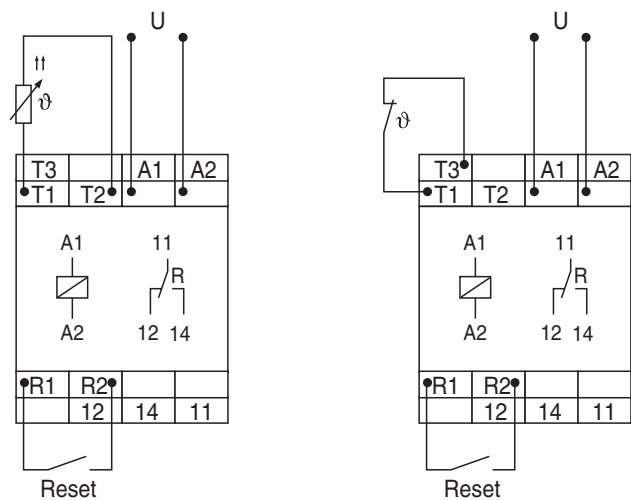

Monitoring Temperature sensor with short circuit monitoring

Monitoring Thermal contact without short circuit monitoring

Load limit curves

EMR IT13G

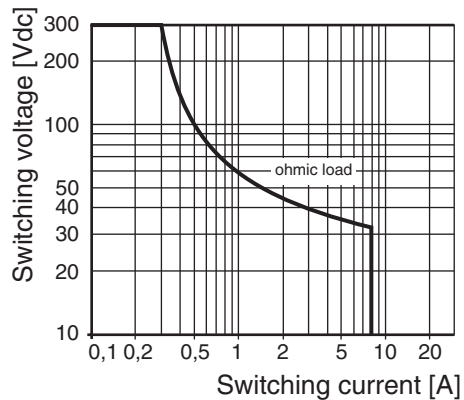

Dimensions

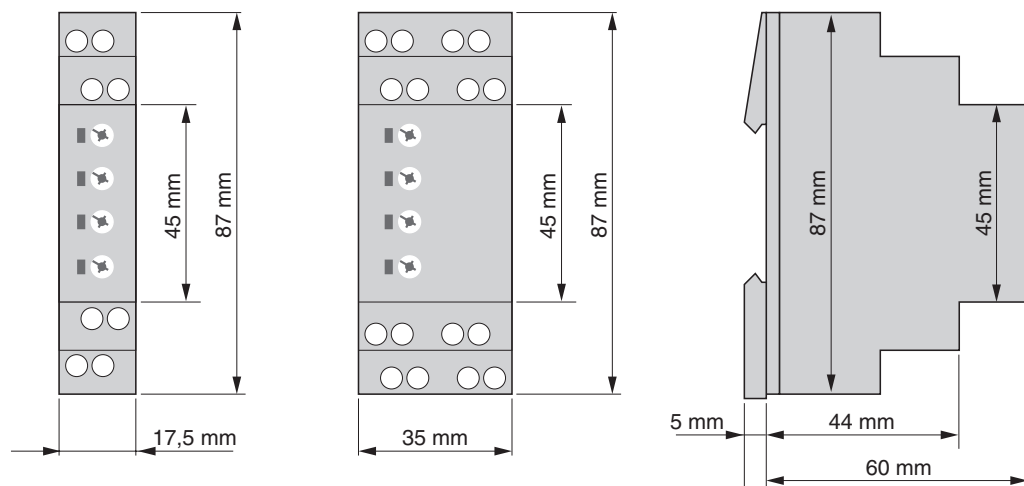

Technical safety advice

This manual contains the information necessary for the correct utilisation of the products described therein. It is intended for technically qualified persons who are involved as either

- planning engineers familiar with the safety concepts of automation technology;
- or, operating personnel, who have been instructed in handling automation equipment and have a knowledge of the contents of this manual concerning operation;
- or, installation and servicing personnel possessing the necessary training to repair such an automation system or who have the authority to put such circuits and equipment/systems into operation, to earth or label them according to the relevant safety standards.

The products are constructed, manufactured and tested in compliance with the relevant VDE standards, VDE specifications and IEC recommendations.

Danger warning

These warnings serve both as a guide for those persons involved in a project and as safety advice to prevent damage to the products themselves or to associated equipment.

Due to advancements in technology, the wiring diagram on the actual device may be different than shown in this catalogue. In all instances where the actual device diagram is different, the wiring diagram on the device must be used when electrical connections are made.

Correct utilisation, configuration and assembly

The equipment is to be used only for the applications stated in the catalogue and technical literature, and only in conjunction with auxiliary equipment and devices that are recommended or approved by Selectron Systems Ltd.

Further, it should be noted that:

- the automation equipment must be disconnected from any power supply before it is assembled, disassembled or the configuration modified.
- Solid state electronic switches must not be tested with incandescent lamps or connected to a load that exceeds its rating.
- trouble-free and safe operation of the products requires correct transportation as well as appropriate storage, assembly and wiring.
- the systems may only be installed by trained

personnel. In doing so, the relevant requirements contained in VDE 0100, VDE 0113, IEC 364, etc. must be complied with.

Prevention of material damage or personal injury

Additional external safety devices or facilities must be provided wherever significant material damage or even personal injury could result from a fault occurring in an automation system. A defined operating status must be ensured or forced by such devices or facilities (e.g. by independent limit switches, mechanical interlocks, etc.).

Advice concerning planning and installation of the products

- The safety and accident prevention measures applicable to a specific application are to be observed.
- In the case of mains-operated equipment, a check is to be made before putting it into operation to ensure that the preset mains voltage range is suitable for the local supply.
- In the case of a 24 V supply, care must be taken to ensure sufficient electrical insulation of the secondary side. Use only mains power supply units that conform to IEC 364-4-41 or HD 384.04.41 (VDE 0100 Part 410).
- Automation systems and their operating elements are to be installed in such a way that they are sufficiently protected against accidental operation.

Warranty

Selectron Systems Ltd. warrants its products to be free from defects in material and workmanship for a period of one year from the date of shipment. All claims under this warranty must be made within thirty (30) days of the discovery of the defect, and all defective products must be returned at the buyer's expense. Buyer's sole and exclusive right will be limited to, at the option of Selectron Systems Ltd., the repair or replacement by Selectron Systems Ltd., of any defective products for which a claim is made.

In all other matters please refer to the „General terms of business“ concerning Selectron Systems Ltd.

Note

The information given in this documentation corresponds to the state of development at the time of going to press and is therefore not binding. Selectron Systems Ltd. reserves the right to make alterations in the interests of technical advancement or product improvement at any time without giving reasons for doing so.

Prescriptions and standards

Mechanical data	
Housings in self-extinguishing plastic material. Protection mode IP 40	
Fixing on profile rail TS 35 according to EN 60715	
Connection mark according to IEC 60067-1-18a	
Environmental conditions	
Admissible environmental temperatures from -25 °C ... +55 °C (according to IEC 60068-1)	
Storage and transport temperature from -25 °C ... +70 °C	
Relative humidity 15% to 85% (according to IEC 60721-3-3 class 3K3)	
Pollution degree 2, if built-in 3 (according to IEC 60664-1)	
Vibration resistance 10 to 55 Hz 0,35 mm (according to IEC 60068-2-6)	
Shock resistance 15 g 11 ms (according to IEC 60068-2-27)	
Output relay	
Electrical lifetime:	2 x 10 ⁵ switching cycles at 1000 VA ohmic load
Mechanical lifetime:	20 x 10 ⁶ switching cycles
Contact material	AgNi 0,15
Supply voltage	
Frequency range	48 ... 63 Hz
Duty cycle	100%, according to IEC class 1c
Protection	
Protection of the unit	5 A fast
Terminals	
Contact protection according VDE 0106 and VBG 4	
Terminal arrangement and connecting mark according DIN 46 199	
Terminal type:	Terminal connection according to VBG 4 (PZ1 required) IP 20
Terminal variants:	1 wire 0,5 mm ² ... 2,5 mm ² with/without wire end covers
	1 wire 4 mm ² without wire end covers
	2 wires 0,5 mm ² ... 1,5 mm ² with/without wire end covers
	2 wires 2,5 mm ² flexible without wire end covers
max. screw in torque:	1,0 Nm
Insulation	
Overvoltage category	III (according to IEC 60664-1)
Rating surge voltage:	4 kV
Electromagnetic compatibility	
Electrostatic discharge:	6 kV contact, 8 kV air (according to IEC 61000-4-2)
High frequency electromagnetic fields: Level 3, 10 V/m (according to IEC 61000-4-3)	
Fast transients:	4 kV / 5 kHz, 5/50 ns (according to IEC 61000-4-4)
Lightning discharge:	2 kV com., 1 kV dif., (according to IEC 61000-4-5)
Cable running disturbances inducted by HF fields: Level 3, 10 V RMS (according to IEC 71000-4-6)	
Spurious radiation net and aerial network: Class B (according to EN 55011)	
Prescriptions	
Air and leakage paces:	EN 61812-1 (see Insulation)
Test voltage:	EN 61812-1 (see Insulation)
Low voltage directions according to EN 61812-1 (see Insulation)	
EMC emissions:	IEC 61000-6-4
EMC interference stability:	IEC 61000-6-2
Burst:	4 kV / 5 kHz, 5/50 ns (according to IEC 61000-4-4)
ESD:	6 kV contact, 8 kV air (according to IEC 61000-4-2)
Production standard:	according to ISO 9001
Basic standards:	IEC 61000-6-4, IEC 61000-4-2

Solid-state relays

Content

1-, 2- and 3-phases solid-state relays

Type selection.....	2
Printed circuit board mount.....	6
Solid-state relay HM.....	6
Solid-state relay HT.....	8
Solid-state relay HQ.....	10
Standard panel mount package, 1-phase.....	12
Solid-state relay HS, zero voltage switch.....	12
Solid-state relay HS, instantaneous switch.....	16
Standard panel mount package.....	18
Solid-state relay HD.....	18
DIN rail or panel mount with integrated heat sink.....	22
Solid-state relay HD.....	22
Current monitoring module for HD series solid state relays.....	26
Current monitoring HD D0340I.....	26
Standard panel mount package, 3-phases.....	32
Solid-state relay HL.....	32
Solid-state relay HL.....	34
Standard panel mount package, 3-phases reversing contactor.....	36
Solid-state relay HL.....	36
Accessories.....	38
Heat sink for 1- and 3-phases solid-state relays.....	38
Accessories.....	40
Heat sink for 1-phase solid-state relays printed circuit board mount.....	40
Ventilator for 1- and 3-phases solid-state relays.....	41
DIN-mounting.....	42
Application notes.....	43
Technical safety advice.....	44
Application notes (SSR).....	45
SSR Applications.....	58
Glossary of terms.....	65

Edition 02.2013

Subject to technical changes and amendments to
technical specifications at any time

Type selection

1-phase solid-state relays / Zero voltage switching AC

Load voltage range	Load current range	Control voltage range	Construction	Type	Page
12 ... 275 VAC	5 mA ... 4 A	4 ... 30 VDC	M	HM D2704	8.6
24 ... 600 VAC	5 mA ... 5 A (25 A)*	4 ... 14 VDC	T	HT D6005L	8.8
48 ... 530 VAC	5 mA ... 5 A (25 A)*	8 ... 32 VDC	T	HT D6005H	8.8
48 ... 530 VAC	5 mA... 10 A	4 ... 14 VDC	Q	HQ D6010L	8.10
48 ... 530 VAC	5 mA ... 10 A	8 ... 32 VDC	Q	HQ D6010H	8.10

* Up to 25 A can be switched with corresponding cooling. See thermal diagram on page 8



Construction M



Construction T



Construction Q

1-phase solid-state relays / Instantaneous switches DC

Load voltage range	Load current range	Control voltage range	Construction	Type	Page
2... 60 VDC	5 mA ... 3 A	3 ... 30 VDC	M	HM D0603D	8.6



Construction M

Type selection

1-phase solid-state relays / Zero voltage switching AC

Load voltage range	Load current range	Control voltage range	Construction	Type	Page
12 ... 280 VAC	5 mA ... 25 A	3 ... 32 VDC	S	HS D2825	8.12
12 ... 280 VAC	5 mA ... 25 A	185... 265 VAC/DC	S	HS A2825	8.12
24 ... 600 VAC	5 mA ... 35 A	3,5 ... 32 VDC	S	HS D6035	8.12
12 ... 280 VAC	5 mA ... 50 A	3 ... 32 VDC	S	HS D2850	8.14
24 ... 600 VAC	5 mA ... 50 A	3,5 ... 32 VDC	S	HS D6050	8.14
24 ... 510 VAC	5 mA ... 50 A	20 ... 265 VAC/DC	S	HS A5150	8.14
24 ... 600 VAC	5 mA ... 75 A	3,5 ... 32 VDC	S	HS D6075	8.15
24 ... 510 VAC	5 mA ... 75 A	20 ... 265 VAC/DC	S	HS A5175	8.15
24 ... 600 VAC	5 mA ... 125 A	3,5 ... 32 VDC	S	HS D51125	8.15
12 ... 280 VAC	5 mA ... 25 A	3,5 ... 32 VDC	D	HD D2825	8.18
24 ... 600 VAC	5 mA ... 35 A	3,5 ... 32 VDC	D	HD D6035	8.18
24 ... 600 VAC	5 mA ... 50 A	3,5 ... 32 VDC	D	HD D6050	8.18
24 ... 600 VAC	5 mA ... 75 A	3,5 ... 32 VDC	D	HD D6075	8.20



Construction S



Construction D

1-phase solid-state relays / Instantaneous switches AC /DC

Load voltage range	Load current range	Control voltage range	Construction	Type	Page
24 ... 510 VAC	5 mA ... 35A	3,5 ... 32 VDC	D	HS D5135M	8.16
5 ... 110 VDC	5 mA ... 20 A	3,5 ... 32 VDC	S	HS D1120D	8.16
5 ... 110 VDC	5 mA ... 40 A	3,5 ... 32 VDC	S	HS D1140D	8.16



Construction S

Type selection

1-phase solid-state relays / Zero voltage switching AC

Load voltage range	Load current range	Control voltage range	Construction	Type	Page
12 ... 280 VAC	5 mA ... 25 A	3,5 ... 32 VDC	D	HD D2825K	8.22
24 ... 600 VAC	5 mA ... 35 A	3,5 ... 32 VDC	D	HD D6035K	8.22
24 ... 600 VAC	5 mA ... 50 A	3,5 ... 32 VDC	D	HD D6050K	8.22
24 ... 600 VAC	5 mA ... 75 A	3,5 ... 32 VDC	D	HD D6075K	8.24



Construction D with heat sink

Type selection

3-phase solide-state relays / Zero voltage switching AC

Load voltage range	Load current range	Control voltage range	Construction	Type	Page
24 ... 520 VAC	3 x 5 mA ... 50 A	8,5 ... 30 VDC	L	HL D5250	8.26
24 ... 520 VAC	3 x 5 mA ... 50 A	90 ... 240 VAC/DC	L	HL A5250	8.26

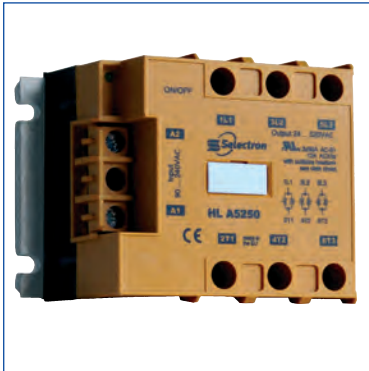

Construction L

3-phase solide-state relays / Zero voltage switching AC with heat sink

Load voltage range	Load current range	Control voltage range	Construction	Type	Page
24 ... 520 VAC	3 x 5 mA ... 22 A	10 ... 30 VDC	L*	HL D5222K	8.28



Construction L*

3-phase solide-state relays / Zero voltage switching AC reversing contactor

Load voltage range	Load current range	Control voltage range	Construction	Type	Page
24 ... 520 VAC	3 x 100 mA ... 8,5 A	12 ... 30 VDC	L	HL D5208R	8.30



Construction L

Printed circuit board mount

Solid-state relay HM

- Control voltage range: 4 ... 30 VDC, 3 ... 30 VDC
- Load voltage range: 12 ... 275 VAC, 2 ... 60 VDC
- Load current range: 5 mA ... 4 A, 5 mA ... 3 A



Construction M

Dimensions

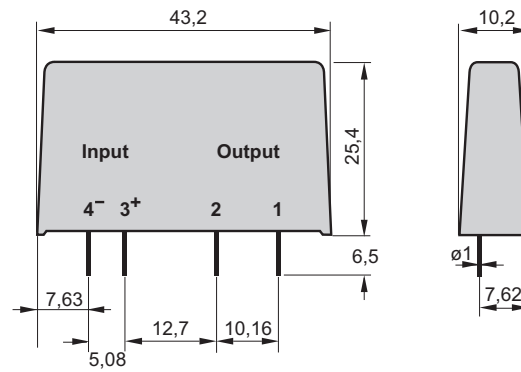

HM D2704
HM D0603D

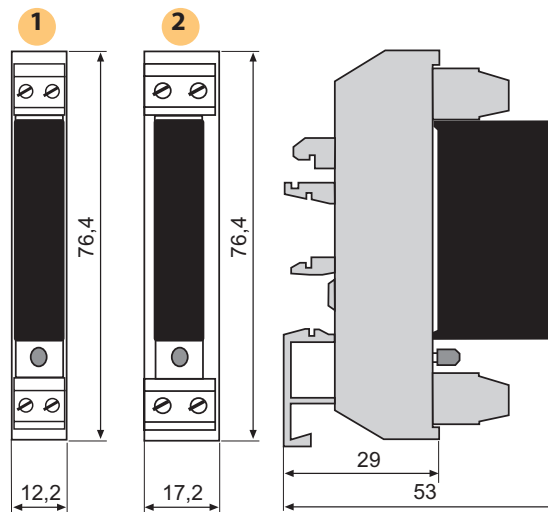

HM D2704 PG 1
HM D0603D PG 1
HM D6004 PG 2

Thermal diagrams

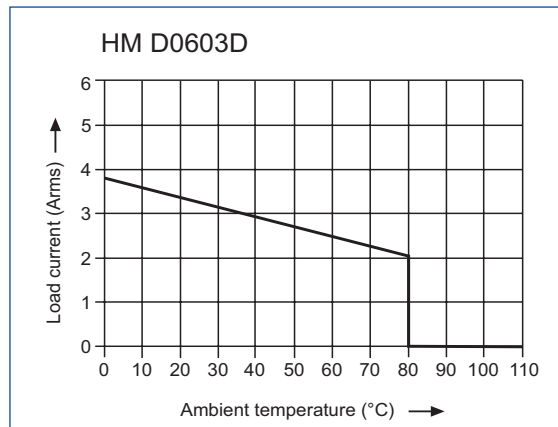
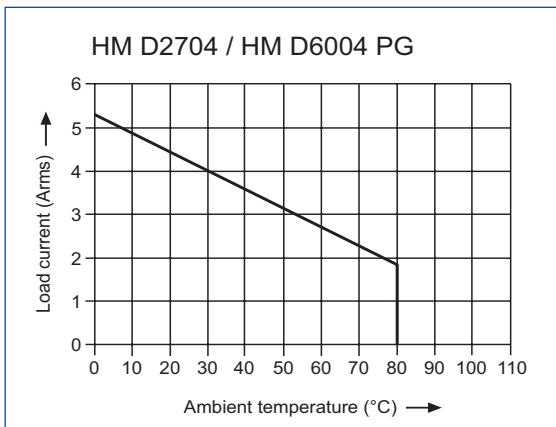

Printed circuit board mount

Solid-state relay HM

Technical data	HM D2704	HM D0603D	HM D6004 PG
Zero switching	Yes	–	Yes
Instantaneous switching-on	–	Yes	–
Control circuit	DC	DC	DC
Load circuit	AC	DC	AC
Load circuit			
Voltage range	12 ... 275 VAC	2 ... 60 VDC	24 ... 600 VAC
Operating frequency range	10 ... 440 Hz	–	10 ... 440 Hz
Transient overvoltage	600 V	60 V	1200 V
Load current range	5 mA ... 4 A	5 mA ... 3 A	5 mA ... 4 A
Max. surge current (10 ms/AC; 1 s/DC)	100 A	10 A	120 A
Max. off-state leakage current (rated voltage)	0,3 mA	1 mA	0,3 mA
Min. off-state du/dt	500 V/μs	200 V/μs	500 V/μs
Max. on-state voltage drop	1,6 V	1,6 V	1,6 V
Max. turn-on time	10 ms	200 μs	10 ms
Max. turn-off time	10 ms	800 μs	10 ms
Max. I ² t for fusing (< 10 ms)	50 A ² s	3 A	72 A ² s
Control circuit			
Control voltage range	4 ... 30 VDC	3 ... 30 VDC	5 ... 30 VDC
Must release voltage	0,8 VDC	1 VDC	0,8 VDC
Nominal input impedance	1000 Ω	1000 Ω	1000 Ω
Typical input current at nominal voltage	3 mA	1 mA	3 mA
Generalities			
Insulation input/output	4000 Vrms	2500 Vrms	4000 Vrms
Galvanic insulation input ↔ output	Yes	Yes	Yes
Ambient operating temperature range	-40 ... +80 °C	-40 ... +80 °C	
Ambient storage temperature range	-40 ... +150 °C	-40 ... +105 °C	
Weight (typical)	20 g	20 g	
Approvals	UL	–	
Article number	42310081	42310080	
(Order data see chapter 1)			

Mounted on profile housing	HM D2704 PG	HM D0603D PG	HM D6004 PG
Generalities			
Ambient operating temperature range	-40 ... +80 °C	-40 ... +80 °C	-40 ... +80 °C
Ambient storage temperature range	-40 ... +150 °C	-40 ... +105 °C	-40 ... +105 °C
Weight (typical)	30 g	30 g	30 g
Approvals	UL	–	–
Article number	42310086	42310087	42310088
(Order data see chapter 1)			

Printed circuit board mount

Solid-state relay HT



Construction T

- Control voltage range: 4 ... 14 VDC, 8 ... 32 VDC
- Load voltage range: 24 ... 660 VAC
- Load current range: 5 mA ... 5 A (25)*

Dimensions

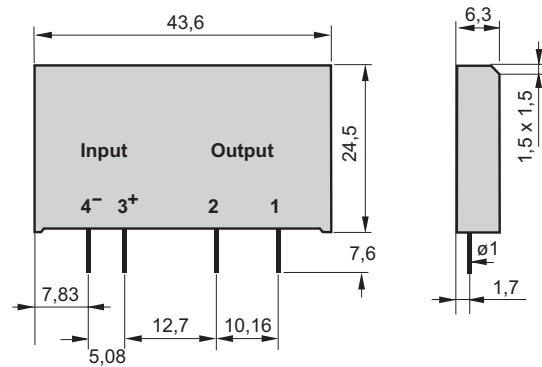

Thermal diagram

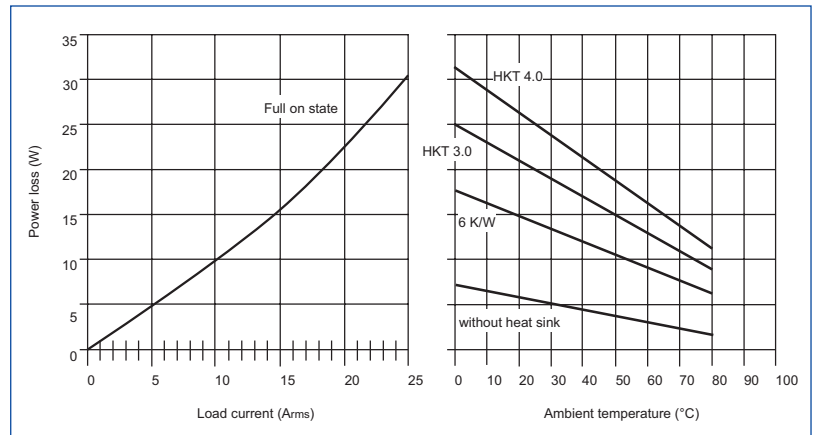

Up to 25 A can be switched with corresponding cooling.

Heat sinks see on pages 32, 33 and 34

Printed circuit board mount

Solid-state relay HT

Technical data	HT D6005L	HT D6005H
Zero switching	Yes	Yes
Instantaneous switching-on	–	–
Control circuit	DC	DC
Load circuit	AC	AC
Load circuit		
Voltage range	24 ... 600 VAC	24 ... 600 VAC
Operating frequency range	10 ... 800 Hz	10 ... 800 Hz
Transient overvoltage	1200 V	1200 V
Load current range	5 mA ... 5 A (25 A)*	5 mA ... 5 A (25 A)*
Max. surge current (10 ms)	300 A	300 A
Max. off-state leakage current (rated voltage)	1 mA	1 mA
Min. off-state du/dt	500 V/μs	500 V/μs
Max. on-state voltage drop	1,6 V	1,6 V
Max. turn-on time	10 ms	10 ms
Max. turn-off time	10 ms	10 ms
Max. I ² t for fusing (< 10 ms)	450 A ² s	450 A ² s
Control circuit		
Control voltage range	4 ... 14 VDC	8 ... 32 VDC
Must release voltage	1 VDC	1 VDC
Nominal input impedance	440 Ω	1640 Ω
Typical input current at nominal voltage	25 mA	13,5 mA
Generalities		
Insulation input/output	4000 Vrms	4000 Vrms
Ambient operating temperature range	-40 ... +80 °C	-40 ... +80 °C
Ambient storage temperature range	-40 ... +120 °C	-40 ... +120 °C
Weight (typical)	15 g	15 g
Approvals	UL	UL
Article number	42310082	42310083
(Order data see chapter 1)		

* Up to 25 A can be switched with corresponding cooling. See thermal diagram

Printed circuit board mount

Solid-state relay HQ

- Control voltage range: 4 ... 140 VDC, 8 ... 32 VDC
- Load voltage range: 24 ... 600 VAC
- Load current range: 5 mA ... 10 A (25 Arms)*



Construction Q

Dimensions

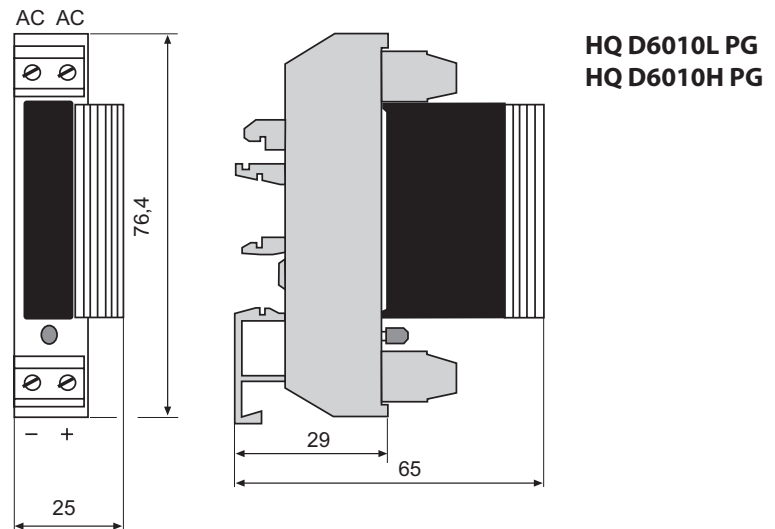
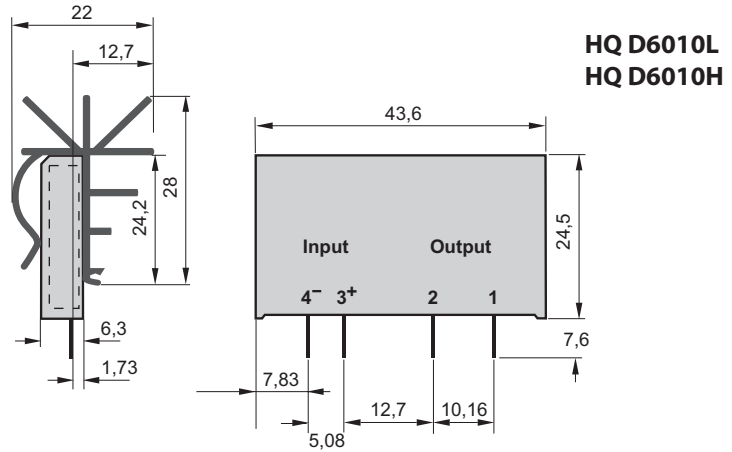

Thermal diagrams

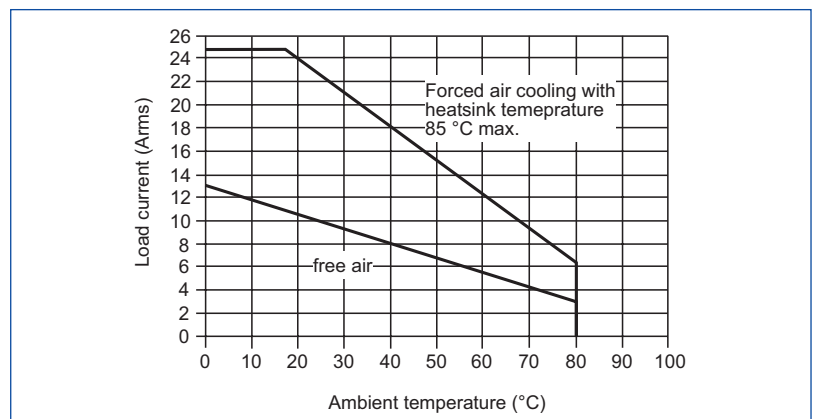

Up to 25 A can be switched with corresponding cooling.

Printed circuit board mount

Solid-state relay HQ

Technical data	HQ D6010L	HQ D6010H
Zero switching	Yes	Yes
Instantaneous switching-on	–	–
Control circuit	DC	DC
Load circuit	AC	AC
Load circuit		
Voltage range	24 ... 600 VAC	24 ... 600 VAC
Operating frequency range	10 ... 440 Hz	10 ... 440 Hz
Transient overvoltage	1200 V	1200 V
Load current range	5 mA ... 10 A (25A)*	5 mA ... 10 A (25A)*
Max. surge current (10 ms)	300 A	300 A
Max. off-state leakage current (rated voltage)	1 mA	1 mA
Min. off-state du/dt	500 V/μs	500 V/μs
Max. on-state voltage drop	1,6 V	1,6 V
Max. turn-on time	10 ms	10 ms
Max. turn-off time	10 ms	10 ms
Max. I ² t for fusing (10 ms)	260 A ² s	260 A ² s
Control circuit		
Control voltage range	4 ... 14 VDC	8 ... 32 VDC
Must release voltage	1 VDC	1 VDC
Nominal input impedance	440 Ω	1640 Ω
Typical input current at nominal voltage	25 mA	13,5 mA
Generalities		
Insulation input/output	4000 Vrms	4000 Vrms
Ambient operating temperature range	-40 ... +80 °C	-40 ... +80 °C
Ambient storage temperature range	-40 ... +120 °C	-40 ... +120 °C
Weight (typical)	30 g	30 g
Approvals	–	–
Article number	42310084	42310085
(Order data see chapter 1)		

* Up to 25 A can be switched with corresponding cooling. See thermal diagram

Mounted on profile housing	HQ D6010L PG	HQ D6010H PG
Generalities		
Ambient operating temperature range	-40 ... +80 °C	-40 ... +80 °C
Ambient storage temperature range	-40 ... +120 °C	-40 ... +120 °C
Weight (typical)	45 g	45 g
Approvals	–	–
Article number	42310091	42310092
(Order data see chapter 1)		

Standard panel mount package, 1-phase

Solid-state relay HS, zero voltage switch

- Control voltage range: 3... 32 VDC, 20 ... 265 VAC/DC
- Load voltage range: 12 ... 660 VAC
- Load current range: 5 mA ... 125 A



Construction S

Dimensions

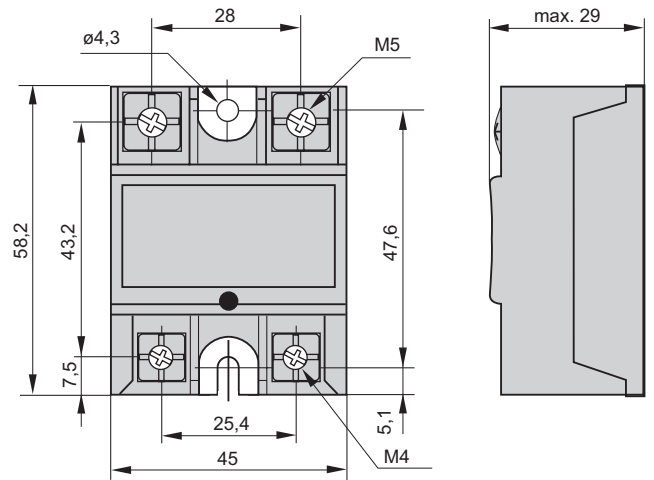

Heat sinks see on pages 32, 33 and 34

Thermal diagrams (all relays already have heat conduction foil)

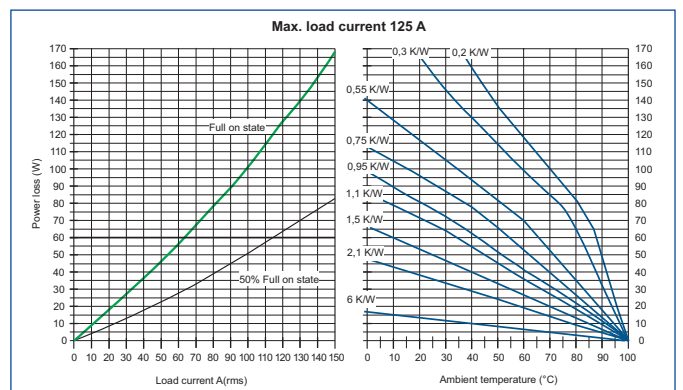
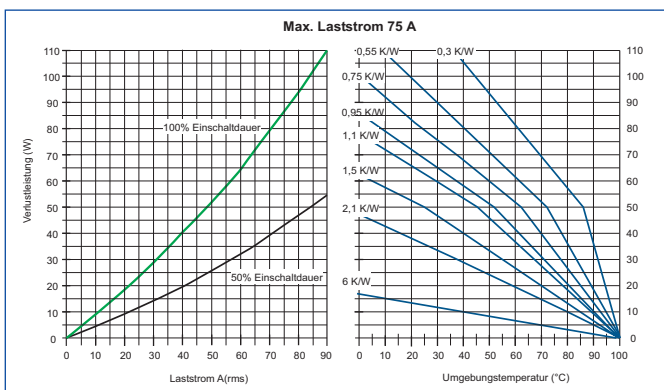
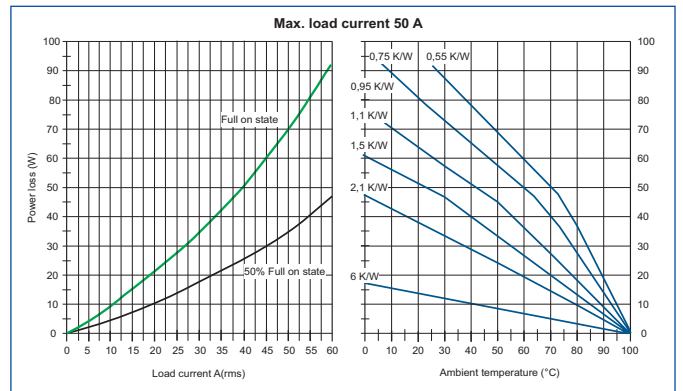
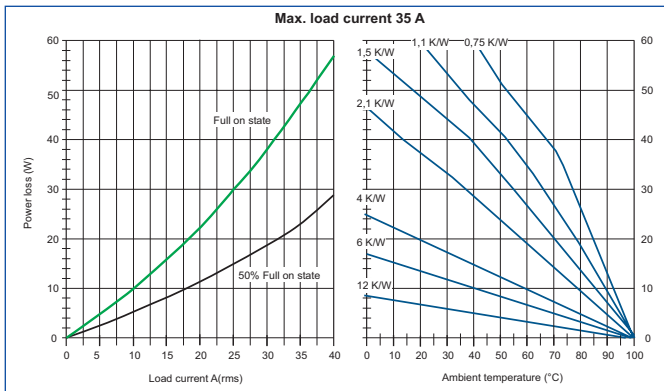
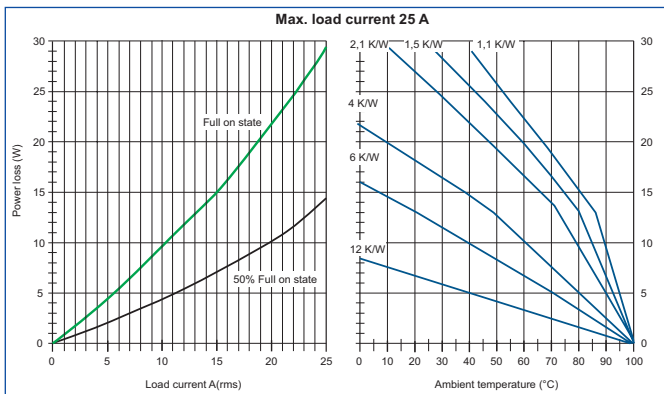

Standard panel mount package, 1-phase

Solid-state relay HS , zero voltage switch

Technical specifications	HS D2825	HS A2825	HS D6035
Zero switching	Yes	Yes	Yes
Instantaneous switching-on	–	–	–
Control circuit	DC	AC/DC	DC
Load circuit	AC	AC	AC
Load circuit			
Voltage range	12 ... 280 VAC	12 ... 280 VAC	24 ... 600 VAC
Operating frequency range	0,1 ... 800 Hz	0,1 ... 800 Hz	0,1 ... 800 Hz
Transient overvoltage	600 V	600 V	1200 V
Load current range	5 mA ... 25 A	5 mA ... 25 A	5 mA ... 35 A
Max. surge current (10 ms)	350 A	350 A	500 A
Max. off-state leakage current (rated voltage)	1 mA	1 mA	1 mA
Min. off-state du/dt	500 V/μs	500 V/μs	500 V/μs
Max. on-state voltage drop	0,85 V	0,85 V	0,9 V
Max. turn-on time	10 ms	30 ms	10 ms
Max. turn-off time	10 ms	30 ms	10 ms
Max. I ² t for fusing (10 ms)	600 A ² s	600 A ² s	1250 A ² s
Thermal resistance to base	1,7 K/W	1,7 K/W	0,6 K/W
Control circuit			
Control voltage range	3 ... 32 VDC	185 ... 265 VAC/DC	3,5 ... 32 VDC
Must release voltage	2 V	3 V	2 V
Max. reverse voltage	32 V	–	32 V
Typical input current at nominal voltage	< 13 mA	< 10 mA	< 13 mA
Generalities			
Insulation input/output/base	4000/2500 Vrms	4000/2500 Vrms	4000/4000 Vrms
Insulation resistance	1000 MΩ (@ 500 VDC)	1000 MΩ (@ 500 VDC)	1000 MΩ (@ 500 VDC)
Ambient operating temperature range	-55 ... +100 °C	-55 ... +100 °C	-55 ... +100 °C
Ambient storage temperature range	-55 ... +125 °C	-55 ... +125 °C	-55 ... +125 °C
Weight (typical)	85 g	85 g	85 g
Approvals	UL	UL	UL
Screw torque requirements:			
M4 screws (Control circuit)	1,2 Nm	1,2 Nm	1,2 Nm
M5 screws (Load circuit)	2 Nm	2 Nm	2 Nm
Article number	42310203	42310200	42310204
(Order data see chapter 1)			

Standard panel mount package, 1-phase

Solid-state relay HS, zero voltage switch

Technical specifications	HS D2850	HS D6050	HS A5150
Zero switching	Yes	Yes	Yes
Instantaneous switching-on	–	–	–
Control circuit	DC	DC	AC/DC
Load circuit	AC	AC	AC
Load circuit			
Voltage range	12 ... 280 VAC	24 ... 600 VAC	24 ... 510 VAC
Operating frequency range	0,1 ... 800 Hz	0,1 ... 800 Hz	0,1 ... 800 Hz
Transient overvoltage	600 V	1200 V	950 V
Load current range	5 mA ... 50 A	5 mA ... 50 A	5 mA ... 50 A
Max. surge current (10 ms)	720 A	720 A	720 A
Max. off-state leakage current (rated voltage)	1 mA	1 mA	1 mA
Min. off-state du/dt	500 V/μs	500 V/μs	500 V/μs
Max. on-state voltage drop	0,9 V	0,9 V	0,9 V
Max. turn-on time	10 ms	10 ms	30 ms
Max. turn-off time	10 ms	10 ms	30 ms
Max. I ² t for fusing (10 ms)	2500 A ² s	2500 A ² s	2500 A ² s
Thermal resistance to base	0,45 K/W	0,45 K/W	0,45 K/W
Control circuit			
Control voltage range	3 ... 32 Vdc	3,5 ... 32 Vdc	20 ... 265 VAC/DC
Must release voltage	2 V	2 V	5 VDC
Max. reverse voltage	32 V	32 V	–
Typical input current at nominal voltage	< 13 mA	< 13 mA	< 10 mA
Generalities			
Insulation input/output/base	4000/4000 Vrms	4000/4000 Vrms	4000/4000 Vrms
Insulation resistance	1000 MΩ (@ 500 VDC)	1000 MΩ (@ 500 VDC)	1000 MΩ (@ 500 VDC)
Ambient operating temperature range	-40 ... +100 °C	-40 ... +100 °C	-40 ... +100 °C
Ambient storage temperature range	-40 ... +125 °C	-40 ... +125 °C	-40 ... +125 °C
Weight (typical)	85g	85 g	85 g
Approvals	UL	UL	UL
Screw torque requirements:			
M4 screws (Control circuit)	1,2 Nm	1,2 Nm	1,2 Nm
M5 screws (Load circuit)	2 Nm	2 Nm	2 Nm
Article number	42310206	42310207	42310201
(Order data see chapter 1)			

Standard panel mount package, 1-phase

Solid-state relay HS, zero voltage switch

Technical specifications		HS D6075	HS A5175	HS D51125
Zero switching	Yes	Yes	Yes	
Instantaneous switching-on		–	–	–
Control circuit	DC	AC/DC	DC	
Load circuit	AC	AC	AC	
Load circuit				
Voltage range		24 ... 600 VAC	24 ... 510 VAC	24 ... 510 VAC
Operating frequency range		0,1 ... 800 Hz	0,1 ... 800 Hz	0,1 ... 800 Hz
Transient overvoltage		1200 V	950 V	950 V
Load current range		5 mA ... 75 A	5 mA ... 75 A	5 mA ... 125 A
Max. surge current (10 ms)		1200 A	1200 A	2200 A
Max. off-state leakage current (rated voltage)		1 mA	1 mA	1 mA
Min. off-state du/dt		500 V/μs	500 V/μs	500 V/μs
Max. on-state voltage drop		0,9 V	0,9 V	0,9 V
Max. turn-on time		10 ms	30 ms	10 ms
Max. turn-off time		10 ms	30 ms	10 ms
Max. I ² t for fusing (10 ms)		7200 A ² s	7200 A ² s	24'000 A ² s
Thermal resistance to base		0,4 K/W	0,4 K/W	0,25 K/W
Control circuit				
Control voltage range		3,5 ... 32 VDC	20 ... 265 VAC/DC	3,5 ... 32 VDC
Must release voltage		2 V	5 V	2 V
Max. reverse voltage		32 V	–	32 V
Typical input current at nominal voltage		< 13 mA	< 10 mA	< 13 mA
Generalities				
Insulation input/output		4000/4000 Vrms	4000/4000 Vrms	4000/4000 Vrms
Insulation resistance		1000 MΩ (@ 500 VDC)	1000 MΩ (@ 500 VDC)	1000 MΩ (@ 500 VDC)
Ambient operating temperature range		-40 ... +100 °C	-40 ... +100 °C	-40 ... +100 °C
Ambient storage temperature range		-40 ... +125 °C	-40 ... +125 °C	-40 ... +125 °C
Weight (typical)		85 g	85 g	85 g
Approvals		UL	UL	UL
Screw torque requirements:				
M4 screws (Control circuit)		1,2 Nm	1,2 Nm	1,2 Nm
M5 screws (Load circuit)		2 Nm	2 Nm	2 Nm
Article number		42310208	42310202	42310209
(Order data see chapter 1)				

Standard panel mount package, 1-phase

Solid-state relay HS, instantaneous switch



Construction S

- Control voltage range: 3,5 ... 32 VDC
- Load voltage range: 24 ... 510 VAC, 5 ... 110 VDC
- Load current range: 5 mA ... 40 A

Dimensions

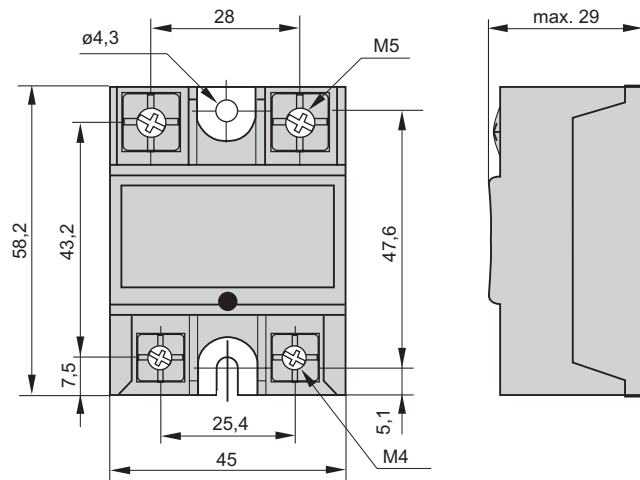

Thermal diagrams (all relays already have heat conduction foil)

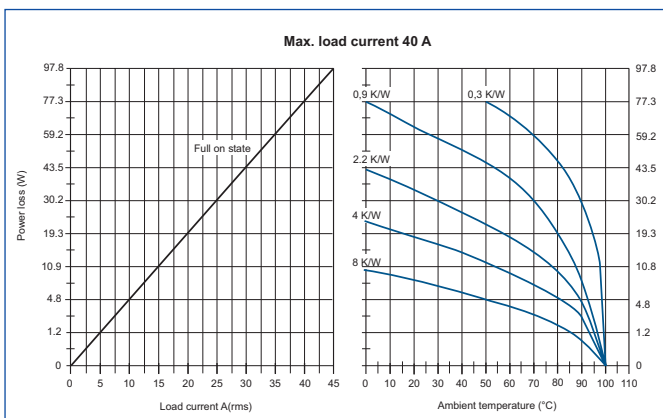
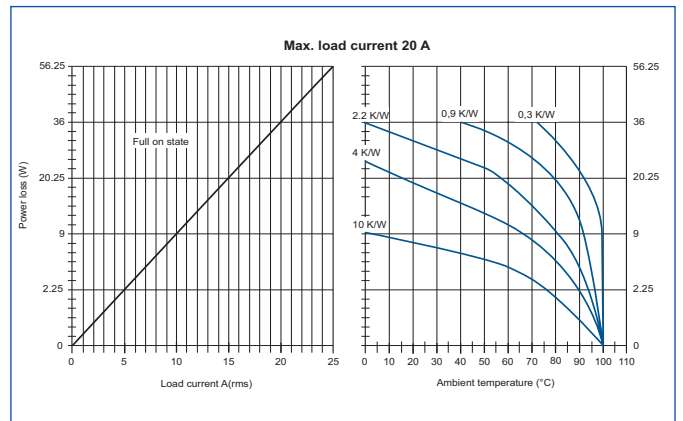
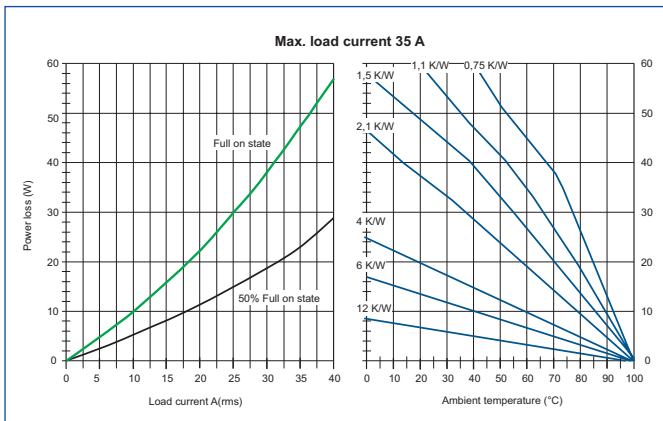

Heat sinks see on pages 32, 33 and 34

Standard panel mount package, 1-phase

Solid-state relay HS, instantaneous switch

Technical specifications	HS D5135M	HS D1120D	HS D1140D
Zero switching	–	–	–
Instantaneous switching-on	Yes	Yes	Yes
Control circuit	DC	DC	DC
Load circuit	AC	DC	DC
Load circuit			
Voltage range	24 ... 510 VAC	5 ... 110 VDC	5 ... 110 VDC
Operating frequency range	0,1 ... 400 Hz	–	–
Transient overvoltage	1200 V	200 V	200 V
Load current range	5 mA ... 35 A	5 mA ... 20 A	5 mA ... 40 A
Max. surge current (10 ms)	500 A	65 A	90 A
Max. off-state leakage current (rated voltage)	3 mA	3 mA	3 mA
Min. off-state dv/dt	500 V/μs	–	–
Max. on-state voltage drop	0,9 V	1,5 V	1,5 V
Max. turn-on time	0,05 ms	40 μs	40 μs
Max. turn-off time	10 ms	40 μs	40 μs
Max. I ² t for fusing (10 ms)	1250 A ² s		
Max. peak current not repetitive 0,1 ms		160 A	280 A
Thermal resistance to base	0,6 K/W	1,2 K/W	0,7 K/W
Control circuit			
Control voltage range	3,5 ... 32 VDC	3,5 ... 32 VDC	3,5 ... 32 VDC
Must release voltage	2 V	1 V	1 V
Max. reverse voltage	32 V	32 V	32 V
Typical input current at nominal voltage	13 mA	35 mA	35 mA
Generalities			
Insulation input/output	4000/4000 Vrms	2500/2500 Vrms	2500/2500 Vrms
Insulation resistance	1000 MΩ (@ 500 VDC)	1 GΩ	1 GΩ
Ambient operating temperature range	-55 ... +100 °C	-25 ... +90 °C	-25 ... +90 °C
Ambient storage temperature range	-55 ... +125 °C	-40 ... +100 °C	-40 ... +100 °C
Weight (typical)	85 g	85 g	85 g
Approvals	–	–	–
Screw torque requirements:			
M4 screws (Control circuit)	1,2 Nm	1,2 Nm	1,2 Nm
M5 screws (Load circuit)	2 Nm	2 Nm	2 Nm
Article number	42310205	42310180	42310181
(Order data see chapter 1)			

Standard panel mount package

Solid-state relay HD

- Control voltage range: 3... 32 VDC
- Load voltage range: 12 ... 600 VAC
- Load current range: 5 mA ... 75 A



Construction D

Dimensions

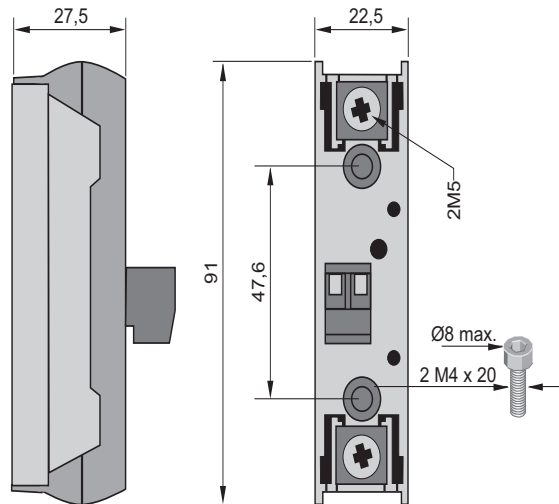

Thermal diagrams

Heat sinks see on pages 32, 33 and 34

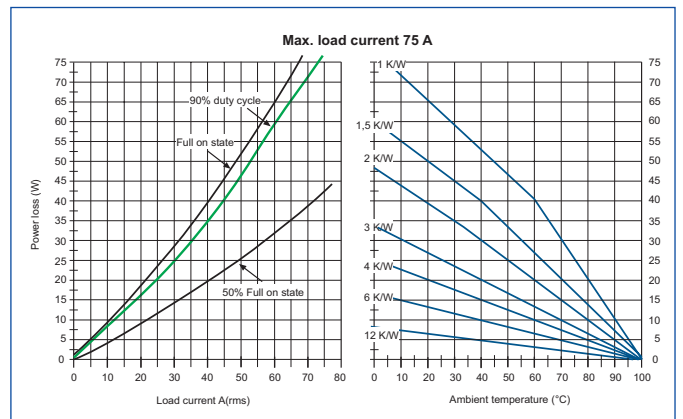
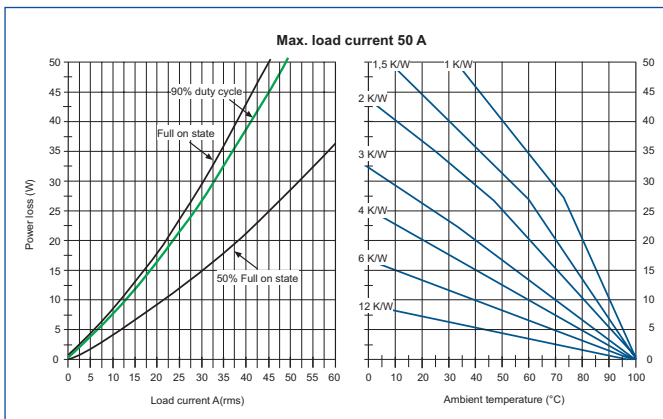
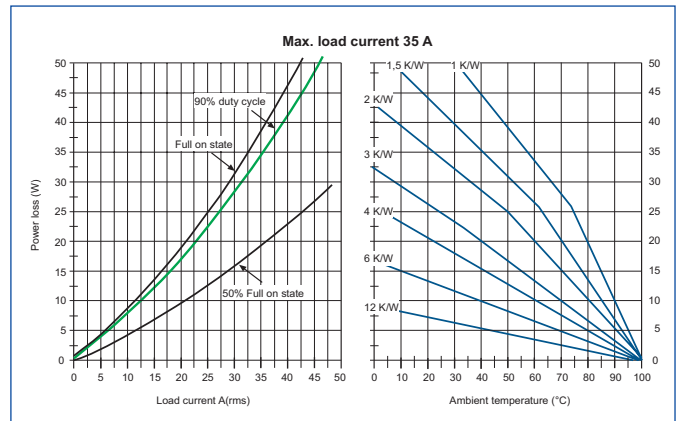
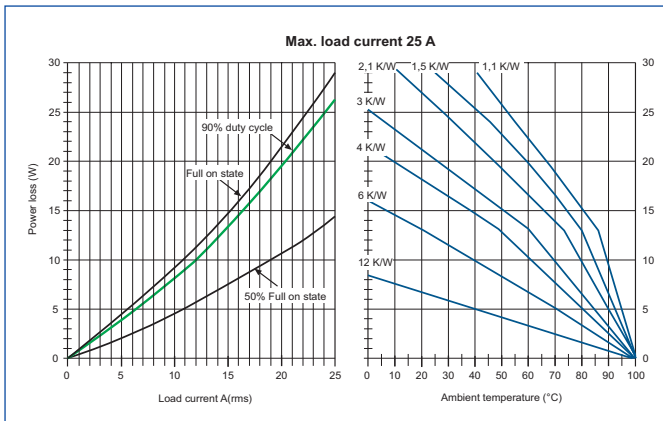

Standard panel mount package

Solid-state relay HD

Technical specifications	HD D2825	HD D6035	HD D6050
Zero switching	Yes	Yes	Yes
Instantaneous switching-on	–	–	–
Control circuit	DC	DC	DC
Load circuit	AC	AC	AC
Load circuit			
Voltage range	12 ... 280 VAC	24 ... 600 VAC	24 ... 600 VAC
Operating frequency range	0,1 ... 800 Hz	0,1 ... 800 Hz	0,1 ... 800 Hz
Transient overvoltage	600 V	1200 V	1200 V
Load current range	5 mA ... 25 A	5 mA ... 35 A	5 mA ... 50 A
Max. surge current (10 ms)	250 A	420 A	580 A
Max. off-state leakage current (rated voltage)	1 mA	1 mA	1 mA
Min. off-state du/dt	500 V/μs	500 V/μs	500 V/μs
Max. on-state voltage drop	0,85 V	0,85 V	0,85 V
Max. turn-on time	10 ms	10 ms	10 ms
Max. turn-off time	10 ms	10 ms	10 ms
Max. I ² t for fusing (10 ms)	340 A ² s	882 A ² s	1680 A ² s
Thermal resistance to base	1,8 K/W	0,7 K/W	0,6 K/W
Control circuit			
Control voltage range	3 ... 32 VDC	3,5 ... 32 VDC	3,5 ... 32 VDC
Must release voltage	2 VDC	2 VDC	2 VDC
Max. reverse voltage	32 V	32 V	32 V
Typical input current at nominal voltage	14 mA	14 mA	14 mA
Generalities			
Insulation input/output/base	4000/4000 Vrms	4000/4000 Vrms	4000/4000 Vrms
Insulation resistance	1000 MΩ (@ 500 VDC)	1000 MΩ (@ 500 VDC)	1000 MΩ (@ 500 VDC)
Ambient operating temperature range	-40 ... +80 °C	-40 ... +80 °C	-40 ... +80 °C
Ambient storage temperature range	-40 ... +125 °C	-40 ... +125 °C	-40 ... +125 °C
Weight (typical)	75 g	75 g	75 g
Approvals	UL	UL	UL
Screw torque requirements:			
Load circuit M5	2 Nm	2 Nm	2 Nm
Control circuit	Depending on the plug terminal used		
Article number	42310250	42310251	42310252
(Order data see chapter 1)			

Standard panel mount package

Solid-state relay HD

Technical specifications	HD D6075
Zero switching	Yes
Instantaneous switching-on	–
Control circuit	DC
Load circuit	AC
Load circuit	
Voltage range	24 ... 600 VAC
Operating frequency range	0,1 ... 800 Hz
Transient overvoltage	1200 V
Load current range	5 mA ... 75 A
Max. surge current (10 ms)	1200 A
Max. off-state leakage current (rated voltage)	1 mA
Min. off-state du/dt	500 V/ μ s
Max. on-state voltage drop	0,85 V
Max. turn-on time	10 ms
Max. turn-off time	10 ms
Max. I ² t for fusing (10 ms)	7200 A ² s
Thermal resistance to base	0,4 K/W
Control circuit	
Control voltage range	3,5 ... 32 VDC
Must release voltage	2 VDC
Max. reverse voltage	32 V
Typical input current at nominal voltage	14 mA
Generalities	
Insulation input/output/base	4000/4000 Vrms
Insulation resistance	1000 M Ω (@ 500 VDC)
Ambient operating temperature range	-40 ... +80 °C
Ambient storage temperature range	-40 ... +125 °C
Weight (typical)	75 g
Approvals	UL
Screw torque requirements:	
Load circuit M5	2 Nm
Control circuit	Depending on the plug terminal used
Article number	42310253
(Order data see chapter 1)	

DIN rail or panel mount with integrated heat sink

Solid-state relay HD



Construction C

- Control voltage range: 3 ... 32 VDC
- Load voltage range: 12 ... 600 VAC
- Load current range: 5 mA ... 35 A

Dimensions

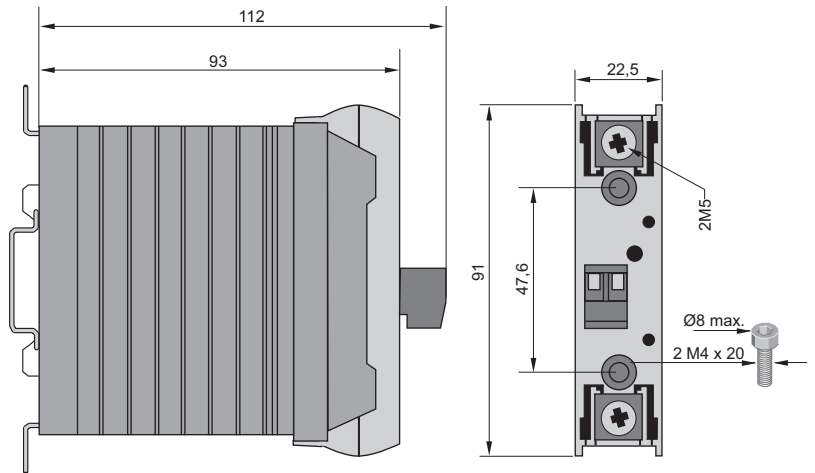

Thermal diagrams

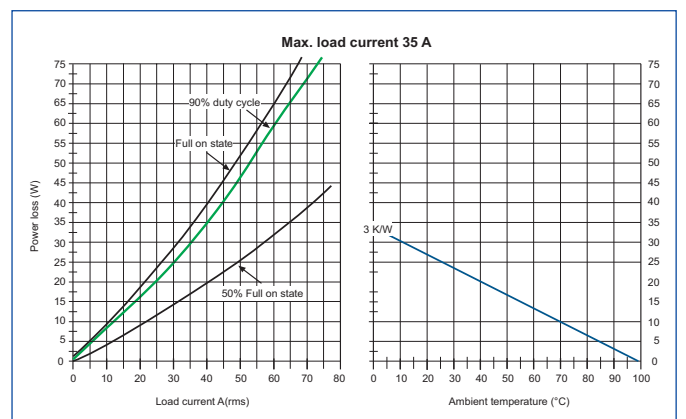
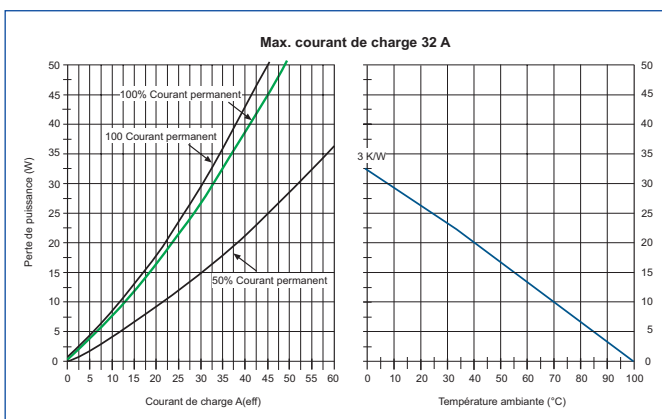
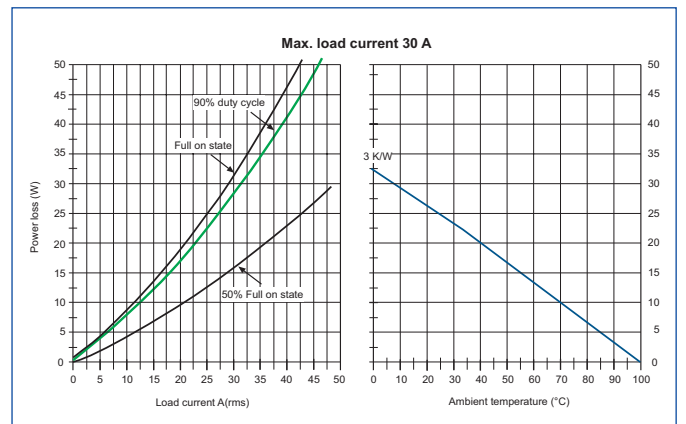
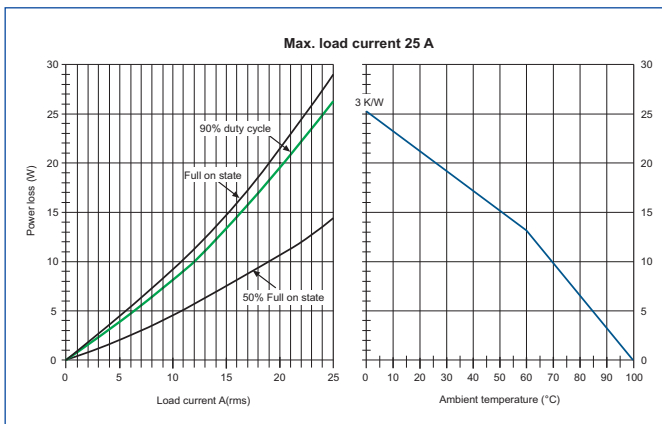

DIN rail or panel mount with integrated heat sink

Solid-state relay HD

Technical specifications	HD D2825K	HD D6035K	HD D6050K
Zero switching	Yes	Yes	Yes
Instantaneous switching-on	–	–	–
Control circuit	DC	DC	DC
Load circuit	AC	AC	AC
Load circuit			
Voltage range	12 ... 280 VAC	24 ... 600 VAC	24 ... 600 VAC
Operating frequency range	0,1 ... 800 Hz	0,1 ... 800 Hz	0,1 ... 800 Hz
Transient overvoltage	600 V	1200 V	1200 V
Load current range	5 mA ... 25 A	5 mA ... 30 A	5 mA ... 32 A
Thyristor value	5 mA ... 25 A	5 mA ... 35 A	5 mA ... 50 A
Max. surge current (10 ms)	250 A	420 A	580 A
Max. off-state leakage current (rated voltage)	1 mA	1 mA	1 mA
Min. off-state du/dt	500 V/μs	500 V/μs	500 V/μs
Max. on-state voltage drop	0,85 V	0,85 V	0,85 V
Max. turn-on time	10 ms	10 ms	10 ms
Max. turn-off time	10 ms	10 ms	10 ms
Max. I ² t for fusing (10 ms)	340 A ² s	882 A ² s	1680 A ² s
Thermal resistance to base	1,8 K/W	0,7 K/W	0,6 K/W
Control circuit			
Control voltage range	3 ... 32 VDC	3,5 ... 32 VDC	3,5 ... 32 VDC
Must release voltage	2 VDC	2 VDC	2 VDC
Max. reverse voltage	32 V	32 V	32 V
Typical input current at nominal voltage	14 mA	14 mA	14 mA
Generalities			
Insulation input/output/base	4000/4000 Vrms	4000/4000 Vrms	4000/4000 Vrms
Insulation resistance	1000 MΩ (@ 500 VDC)	1000 MΩ (@ 500 VDC)	1000 MΩ (@ 500 VDC)
Ambient operating temperature range	-40 ... +80 °C	-40 ... +80 °C	-40 ... +80 °C
Ambient storage temperature range	-40 ... +125 °C	-40 ... +125 °C	-40 ... +125 °C
Weight (typical)	230 g	230 g	230 g
Approvals	UL	UL	UL
Screw torque requirements:			
Load circuit M5	2 Nm	2 Nm	2 Nm
Control circuit	Depending on the plug terminal used		
Article number	42310260	42310261	42310262
(Order data see chapter 1)			

Standard panel mount package

Solid-state relay HD

Technical specifications	HD D6075K
Zero switching	Yes
Instantaneous switching-on	–
Control circuit	DC
Load circuit	AC
Load circuit	
Voltage range	24 ... 600 VAC
Operating frequency range	0,1 ... 800 Hz
Transient overvoltage	1200 V
Load current range	5 mA ... 35 A
Thyristor value	5 mA ... 75 A
Max. surge current (10 ms)	1200 A
Max. off-state leakage current (rated voltage)	1 mA
Min. off-state du/dt	500 V/ μ s
Max. on-state voltage drop	0,85 V
Max. turn-on time	10 ms
Max. turn-off time	10 ms
Max. I ² t for fusing (10 ms)	7200 A ² s
Thermal resistance to base	0,4 K/W
Control circuit	
Control voltage range	3,5 ... 32 VDC
Must release voltage	2 VDC
Max. reverse voltage	32 V
Typical input current at nominal voltage	14 mA
Generalities	
Insulation input/output/base	4000/4000 Vrms
Insulation resistance	1000 M Ω (@ 500 VDC)
Ambient operating temperature range	-40 ... +80 °C
Ambient storage temperature range	-40 ... +125 °C
Weight (typical)	230 g
Approvals	UL
Screw torque requirements:	
Load circuit M5	2 Nm
Control circuit	Depending on the plug terminal used
Article number	42310263
(Order data see chapter 1)	

Current monitoring module for HD series solid state relays

Current monitoring HD D0340I



- **Control voltage range: 4 ... 30 VDC**
- **Load current range: 2 A ... 40 A**
- **Permanent current monitoring**
- **Teach-in function with key or external digital input**
- **Alarm threshold: $0,84 \cdot I_{teach}$ (-16%)**
- **No-load monitoring**
- **Power failure monitoring**
- **Partial no-load monitoring**
- **Solid state relay short circuit monitoring**
- **Leakage current monitoring**
- **Straightforward installation on existing relay**

Product description:

The HD D0340I current monitoring module is a supplement to the HD solid state series, and permits monitoring and diagnosis of one or more loads (maximum five loads).

It makes it possible to detect power failure, temporary or permanent no-load as well as a short circuit of the relay. The module uses a current converter permanently to measure the load current, and compares this with the nominal value.

The nominal value can be set either using the Teach key on the front of the module or an external digital Teach input (see setting sequence diagram).

A current -16% lower than the nominal value ($0,84 \times$ nominal value) indicates that there is a temporary no-load condition.

If the module detects a fault, the diagnostic output is activated and the fault type is displayed by the 3 LEDs on the front panel. These LEDs also display all other statuses.

Dimensions of HD series relay with the current monitoring

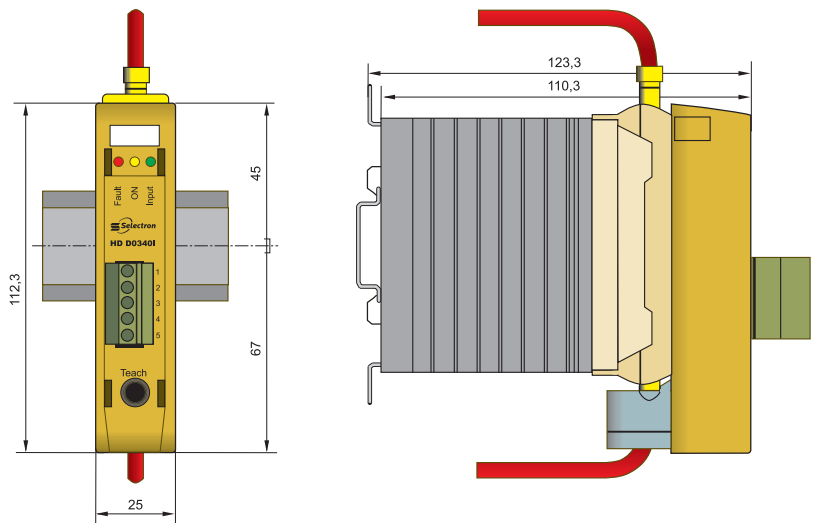

Current monitoring module for HD series solid state relays

Current monitoring HD D0340I

Wiring diagram

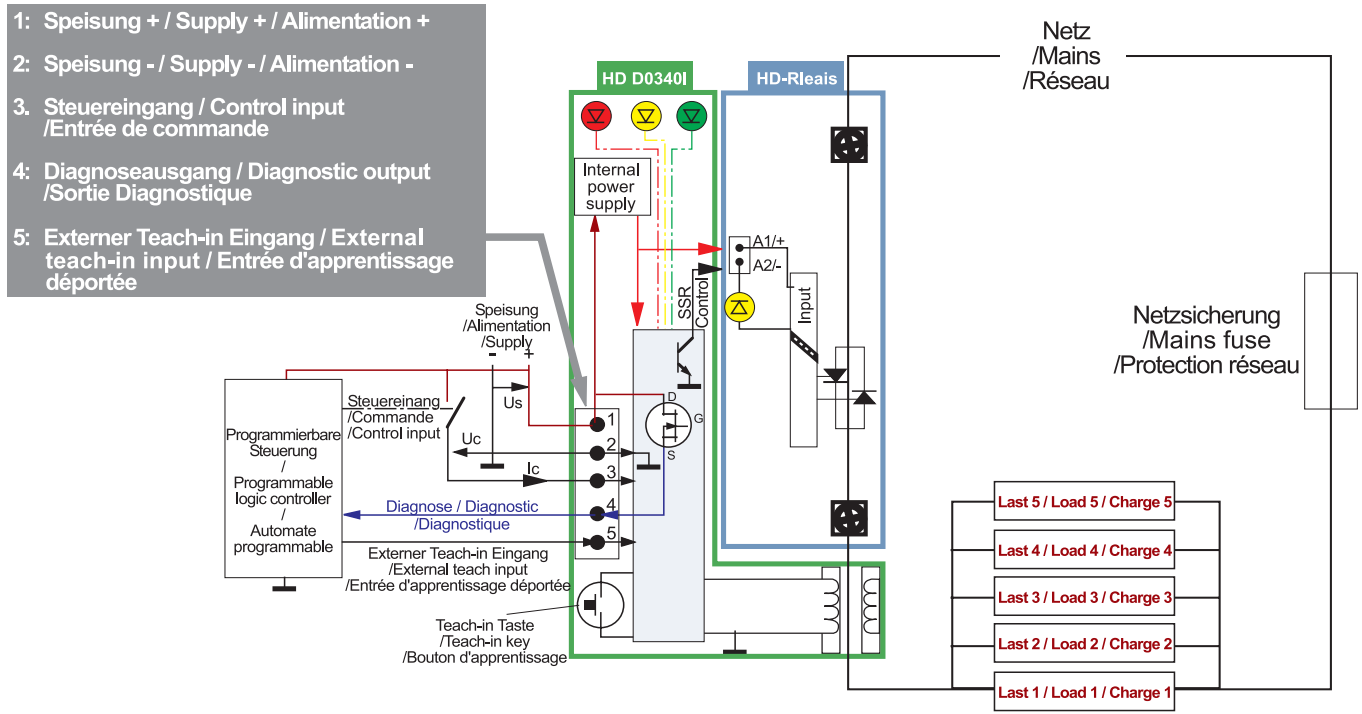

Functional diagram

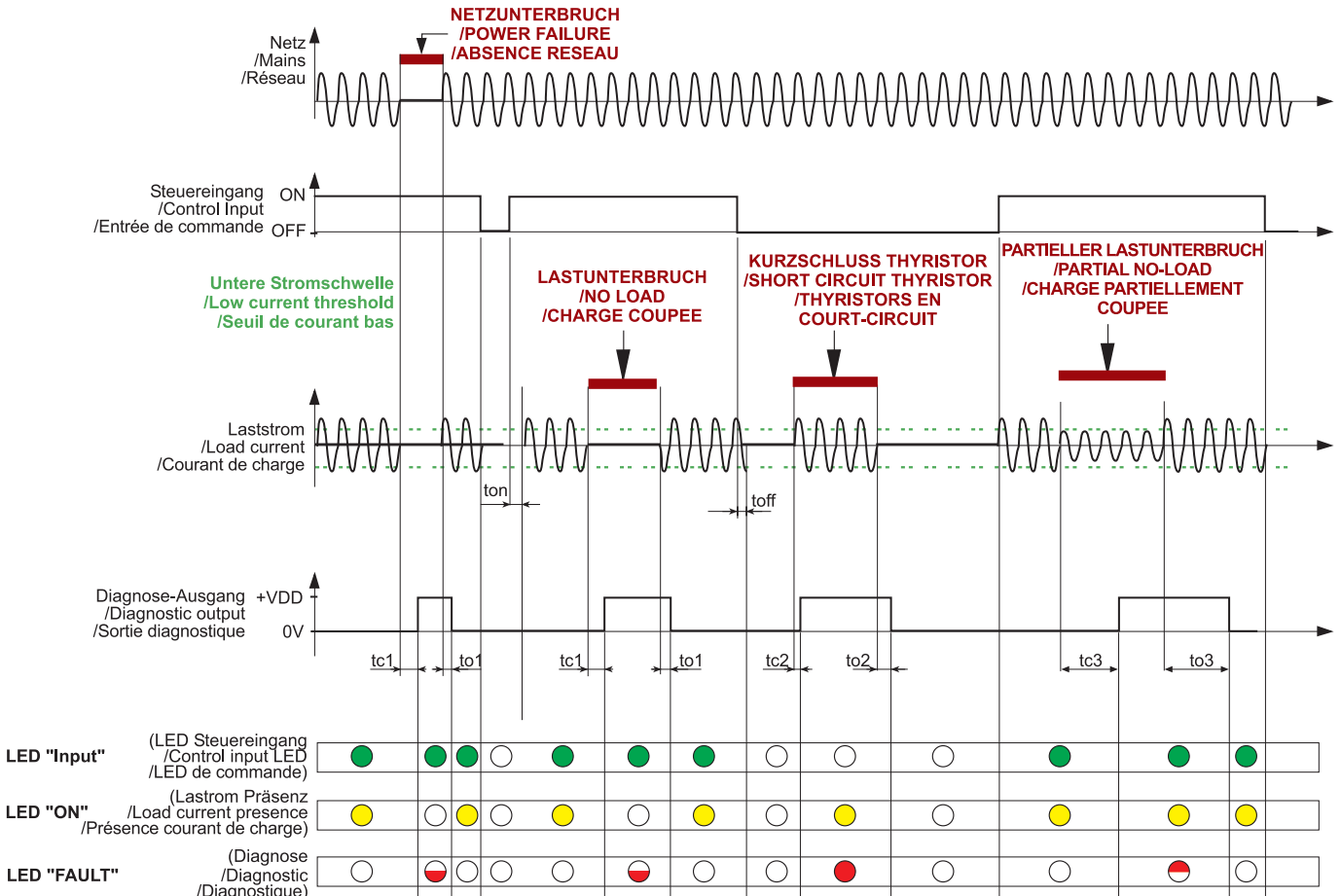

Current monitoring module for HD series solid state relays

Current monitoring HD D0340I

Teaching mode diagram

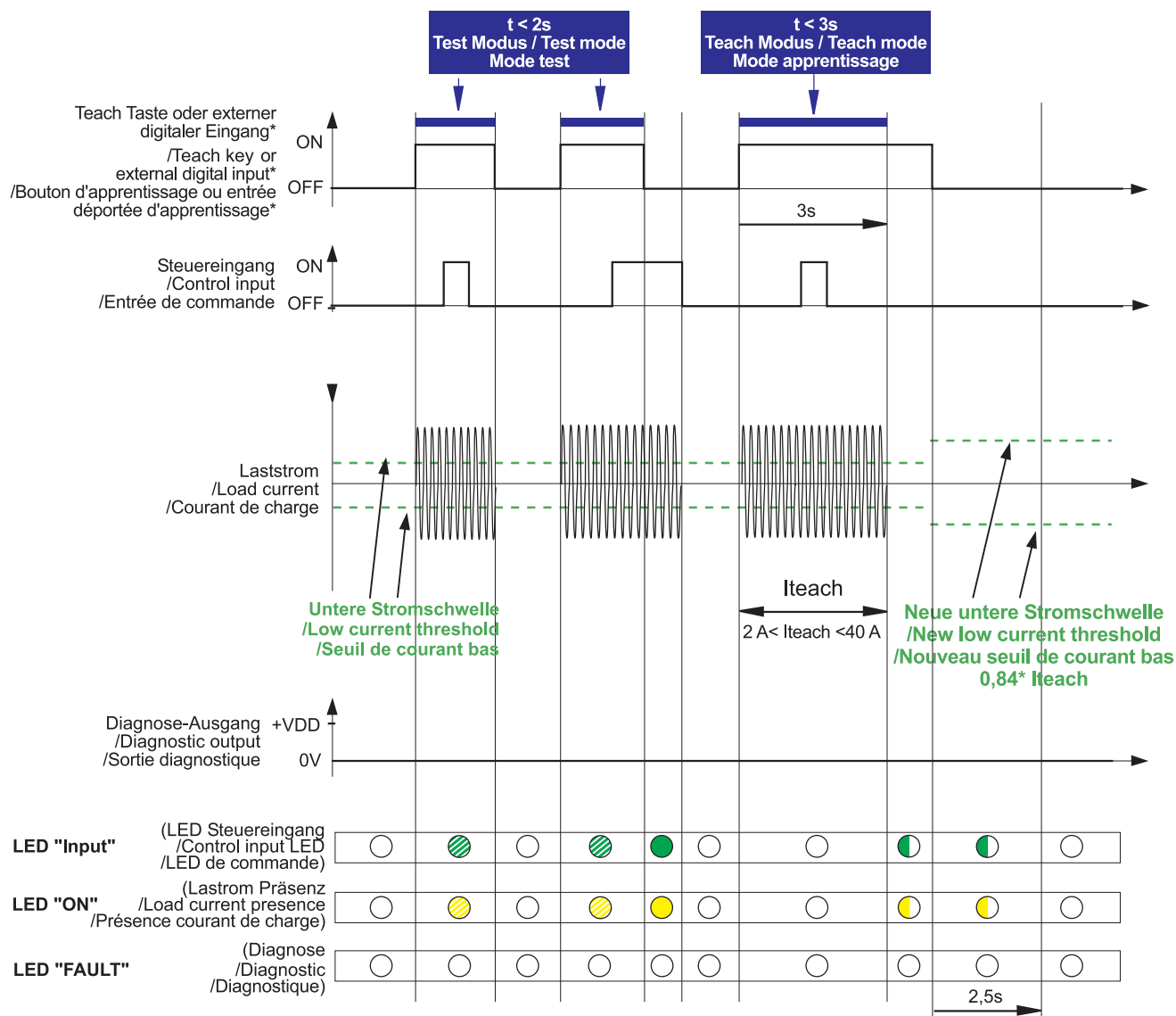

Legende / Legend / Légende		
	OFF	
	ON grün/green/vert	
	ON gelb/yellow/jaune	
	ON rot/red/rouge	
	OFF blinkend/flashing /clignotant	langsam symmetrisch blinkend /slow symmetrical flashing /clignotement symétrique lent (Ton=1s Toff=1s)
	OFF blinkend/flashing /clignotant	schnell symmetrisch blinkend /fast symmetrical flashing /clignotement symétrique rapide (Ton=100ms Toff=100ms)
	OFF blinkend/flashing /clignotant	schnell simultan blinkend /fast simultaneous flashing /clignotement simultané rapide (Ton=100ms Toff=100ms)
	OFF blinkend/flashing /clignotant	langsam simultan blinkend /slow simultaneous flashing /clignotement simultané lent (Ton=1s Toff=1s)

Current monitoring module for HD series solid state relays

Current monitoring HD D0340I

Setting sequence

Brief activation (< 2 s) of the Teach key or the external digital Teach input makes it possible to test the system (relay and load), in which case the control input of the solid state relay is activated.

Longer activation (> 3 s) of the Teach key or the external digital Teach input makes it possible to record and store the load current of the „Iteach“ load (teach mode).

Teach mode must be carried out at a constant load current.

Following activation of the Teach key or the external digital Teach input, the green „INPUT“ LED and the yellow „ON“ LED flash quickly simultaneously ($t_{on} = 100\text{ ms}$) and ($t_{off} = 100\text{ ms}$). If the Teach key is pressed for longer or the digital Teach input is applied for longer (> 3 s) then the two LEDs flash slowly ($t_{on} = 1\text{ s}$) and ($t_{off} = 1\text{ s}$) to indicate that teach mode (Iteach) is active.

When the Teach key is released or the external digital Teach input is switched off, the two LEDs continue to flash for another 2.5 s as an indication that the new nominal value has been stored.

If this new nominal value is outside the monitoring range of $2\text{ A} \dots 40\text{ A}_{rms}$ then the two LEDs flash alternately green and yellow as an indication that diagnosis is not possible.

The LEDs flash until the teach process is restarted.

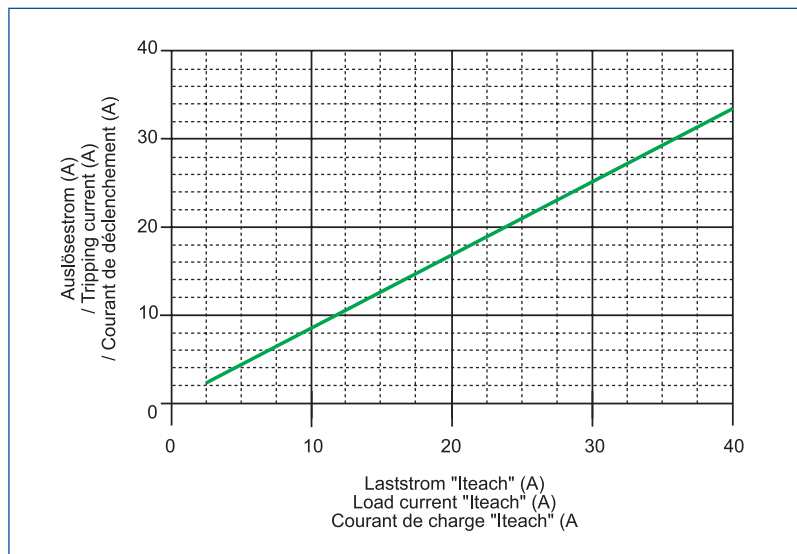
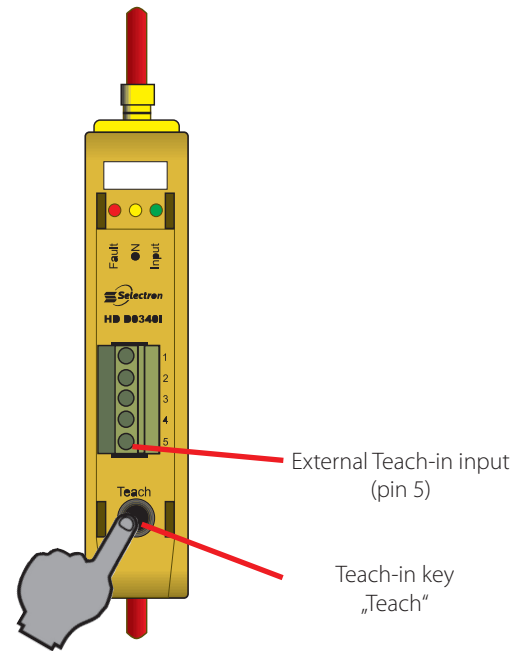

Current monitoring module for HD series solid state relays

Current monitoring HD D0340I

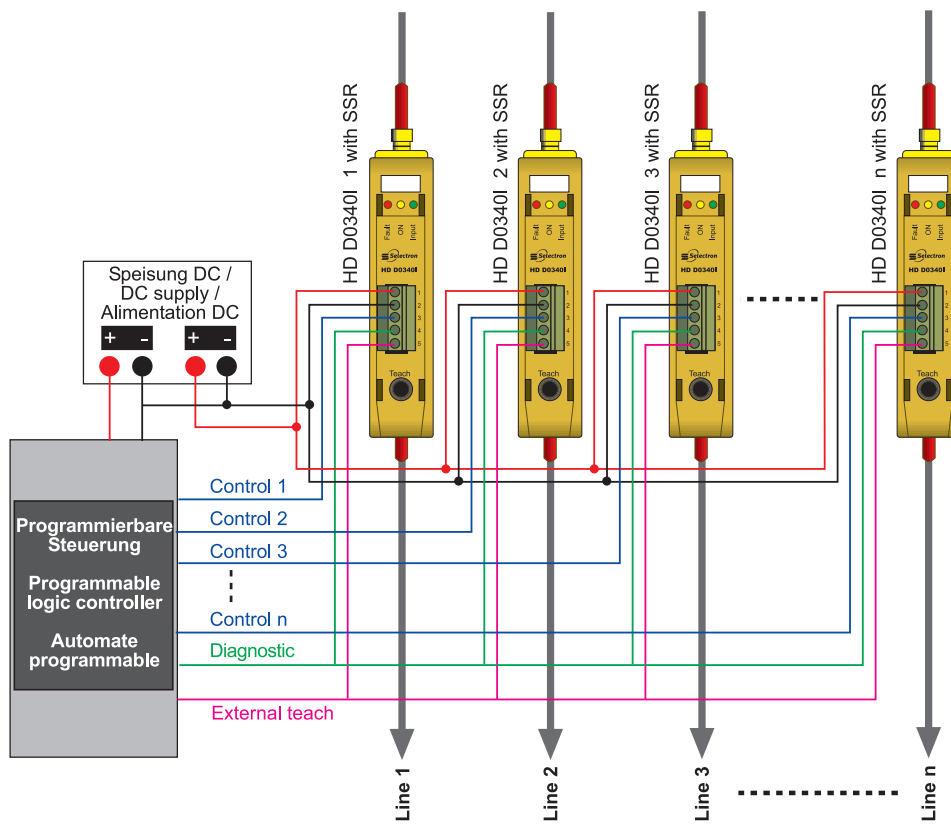

Example of wiring with several modules

The diagnostic outputs of several modules (max. 5) can be connected in parallel to one input of a controller. In the event of a fault, the controller detects a fault and the „Fault“ LED makes it possible to identify the fault type and fault location on the modules.

Technical data of input (at 25°C)	HD D0340I
Control voltage range	4 ... 30 VDC
Control current	0,3 ... 2,5 mA
Release voltage	2 V
Load current range at $T_{\text{ambient}} > 0^{\circ}\text{C}$	2 ... 40 A
Load current range at $T_{\text{ambient}} < 0^{\circ}\text{C}$	4 ... 40 A
Load circuit frequency range	15 ... 200 Hz
Input LED	green
Voltage range of the external digital input	4 ... 30 VDC
Control current of the external digital input	0,3 ... 2,5mA
External digital release voltage	2V
Max. reverse voltage	30V
Input immunity: EN61000-4-4	1kV
Input immunity: EN61000-4-5	1kV

Current monitoring module for solid state relays type HD

Current monitoring module HD D0340I

Technical data of power supply (at 25°C)	HD D0340I
Voltage range	8 ... 30 VDC
Control current	<20 mA
Polarity reversal protection	yes
Surge voltage protection	Varistor

Technical data in general (at 25°C)	HD D0340I
Switch-on time @ 50Hz (t _{on})	15 ms
Switch-off time @ 50Hz (t _{off})	15 ms
Diameter of cable entry for current converter	9 mm
Index of protection CEI520	IP20
Vibration (10 ... 55Hz acc. to IEC 60068-2-6)	2 gn
Schock (1/2 sinusoidal/11 ms acc. to IEC 60068-2-27)	15 gn
Operating temperature range	-40 ... +80°C
Storage temperature range	-40 ... +125°C
Relative humidity	40 ... 85%
Weight	75 g
Compliance with	EN60947-4-3 (IEC947-4-3)
Compliance with	EN60950 / UL/cUL
Housing material	PA 6 UL94V0

Technical data of diagnostic output (at 25°C)	HD D0340I	
Voltage range	8 ... 30 VDC	
Output current	0,1 A	
Output resistance closed	0,2 Ω	
Max. leakage current	0,3 A	
Switch-on time on power failure or no-load	tc1	40 ms
Switch-off time on power failure or no-load	to1	10 ms
Switch-on time on relay short circuit	tc2	10 ms
Switch-off time on relay short circuit	to2	40 ms
Switch-on time on temporary no-load or overload	tc3	100 ms
Switch-off time on temporary no-load or overload	to3	100 ms
Max. start-up time for load current	ts	200 ms

Generalities	HD D0340I
Article number	42310270
Order data see chapter 1)	

Compliant with EN60947-4-3 (IEC947-4-3) and EN60950/VDE0805 (Reinforced Insulation) -UL-cUL pending

Standard panel mount package, 3-phases

Solid-state relay HL

- Control voltage range: 8,5 ... 30 VDC, 90 ... 240 VAC/DC
- Load voltage range: 24 ... 520 VAC
- Load current range: 3 x 50 A



Construction L

Dimensions

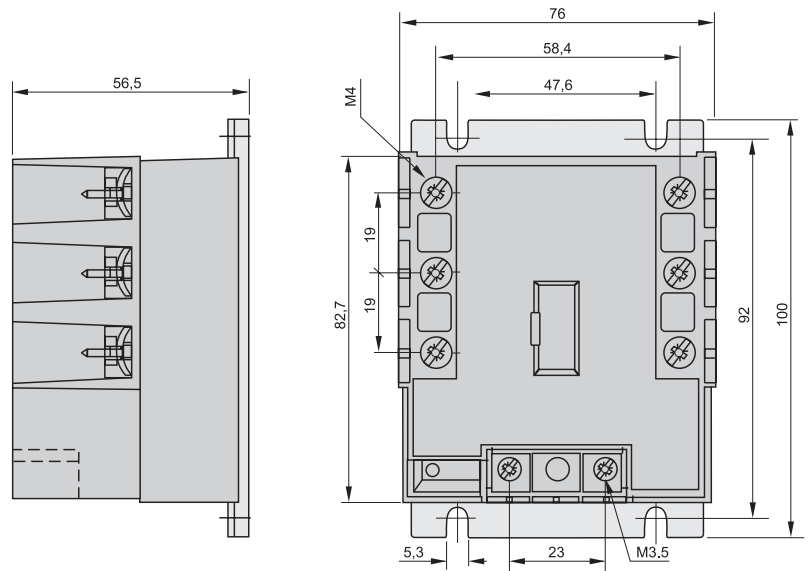

Thermal diagrams

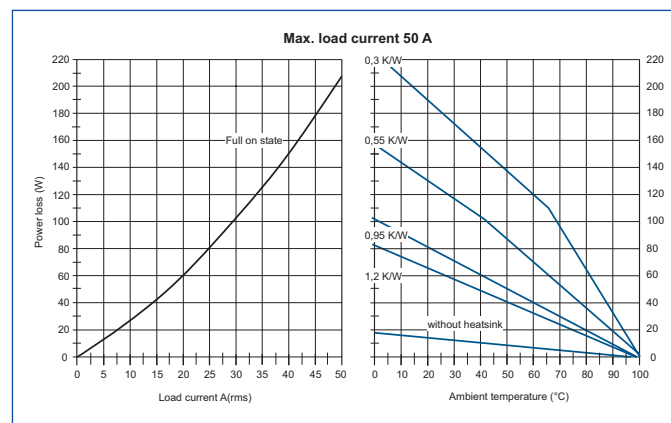

Heat sinks see on pages 32, 33 and 34

Standard panel mount package, 3-phases

Solid-state relay HL

Technical specifications	HL D5250	HL A5250
Zero switching	Yes	Yes
Instantaneous switching-on	–	–
Control circuit	DC	AC
Load circuit	AC	AC
Load circuit		
Voltage range	24 ... 520 VAC	24 ... 520 VAC
Operating frequency range	10 ... 440 Hz	10 ... 440 Hz
Transient overvoltage	1200 V	1200 V
Load current range	3x 5 mA ... 50 A	3x 5 mA ... 50 A
Max. surge current (10 ms)	550 A	550 A
Max. off-state leakage current (rated voltage)	5 mA	5 mA
Min. off-state du/dt	500 V/μs	500 V/μs
Max. on-state voltage drop	1,4 V	1,4 V
Max. turn-on time	10 ms	10 ms
Max. turn-off time	10 ms	10 ms
Max. I ² t for fusing (10 ms)	1500 A ² s	1500 A ² s
Thermal resistance to base	0,7 K/W	0,7 K/W
Control circuit		
Control voltage range	8,5 ... 30 VDC	90 ... 240 VAC/DC
Must release voltage	4 V	4 V
Max. reverse voltage	30 V	–
Typical input current at nominal voltage	35 mA	11 mA
Generalities		
Insulation input/output/base	4000/3300 Vrms	4000/3300 Vrms
Insulation resistance	620 Ω	21 KΩ
Ambient operating temperature range	-40 ... +100 °C	-40 ... +100 °C
Ambient storage temperature range	-40 ... +100 °C	-40 ... +100 °C
Weight (typical)	410 g	410 g
Approvals	UL	UL
Screw torque requirements:		
M3,5 screws (Control circuit)	1,2 Nm	1,2 Nm
M5 screws (Load circuit) 1,8 Nm	1,8 Nm	
Article number	42310143	42310142
(Order data see chapter 1)		

3-phases with integrated heat sink

Solid-state relay HL

- Control voltage range: 10 ... 30 VDC
- Load voltage range: 24 ... 520 VAC
- Load current range: 3 x 22 A



Construction L

Dimensions

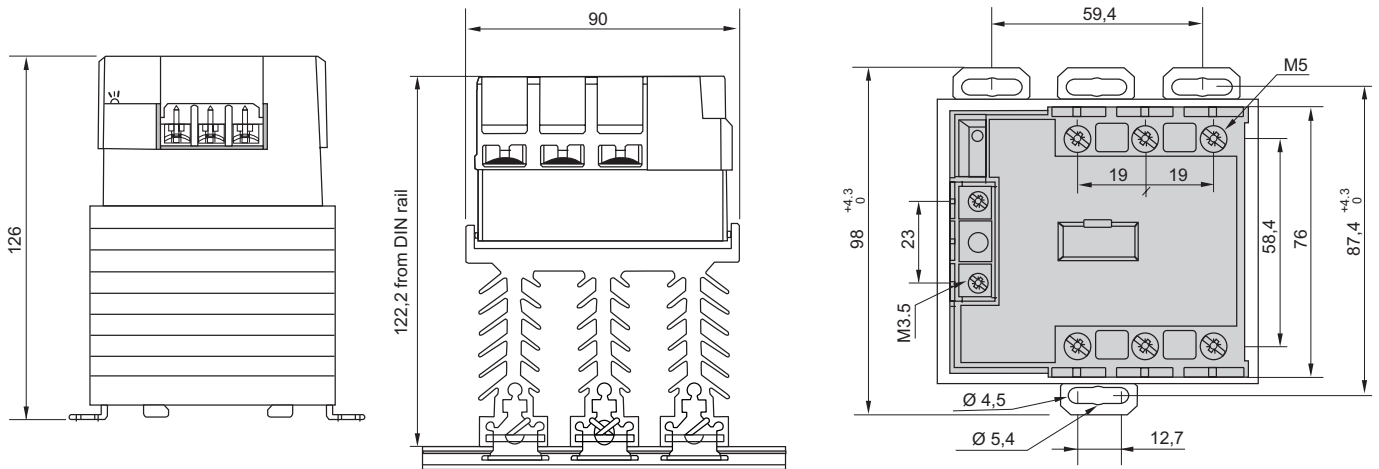

Thermal diagrams

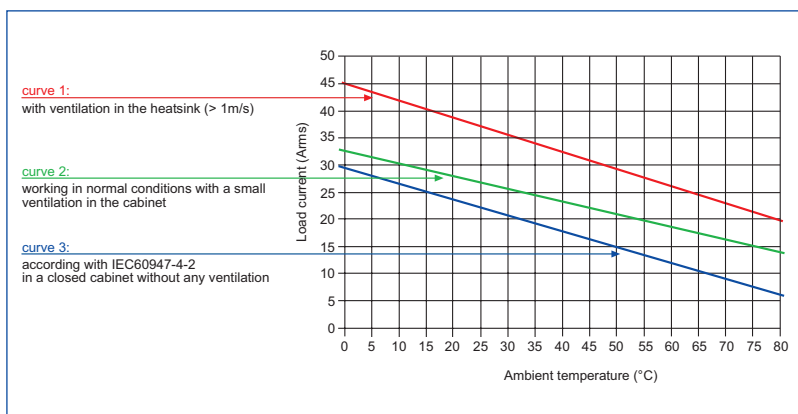

3-phases with with integrated heat sink

Solid-state relay HL

Technical specifications	HL D5222K
Zero switching	Yes
Instantaneous switching-on	–
Control circuit	DC
Load circuit	AC
Load circuit	
Voltage range	24 ... 520 VAC
Operating frequency range	10 ... 440 Hz
Transient overvoltage	1200 V (integrated surge voltage protection 850 V)
Load current range	3x 5 mA ... 22 A
Max. surge current (10 ms)	550 A
Max. off-state leakage current (rated voltage)	1 mA
Min. off-state du/dt	500 V/μs
Max. on-state voltage drop	1,4 V
Max. turn-on time	10 ms
Max. turn-off time	10 ms
Max. I ² t for fusing (10 ms)	1500 A ² s
Thermal resistance to base	–
Control circuit	
Control voltage range	10 ... 30 VDC
Must release voltage	4 VDC
Max. reverse voltage	30 V
Typical input current at nominal voltage	32 mA
Generalities	
Insulation input/output/base	4000/3300 Vrms
Insulation resistance	560Ω
Ambient operating temperature range	-40 ... +80 °C
Ambient storage temperature range	-40 ... +108 °C
Weight (typical)	1000 g
Approvals	UL
Screw torque requirements:	
M3.5screws (Control circuit)	1,2 Nm
M4 screws (Load circuit)	1,8 Nm
Article number	42310144
(Order data see chapter 1)	

Standard panel mount package, 3-phases reversing contactor

Solid-state relay HL

- Control voltage range: 12 ... 30 VDC
- Load voltage range: 24 ... 520 VAC
- Load current range: 3 x 8,5 A



Bauform L

Dimensions

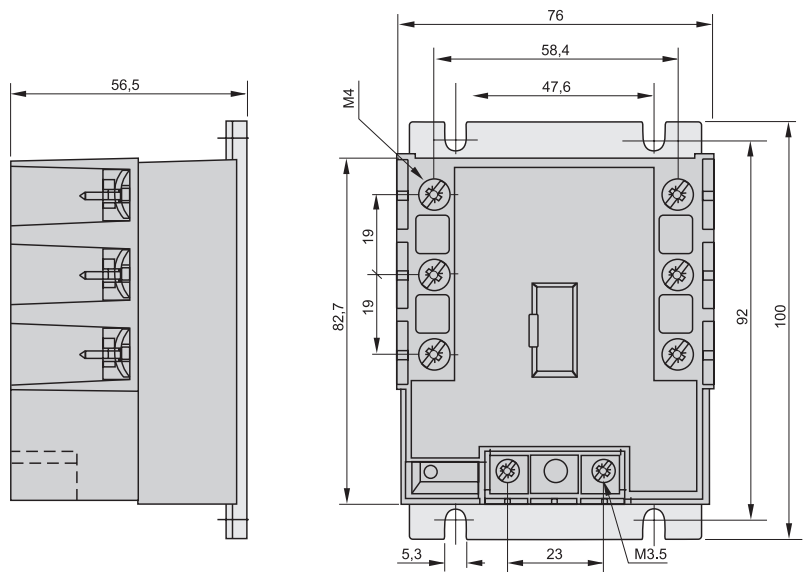

Thermal diagrams

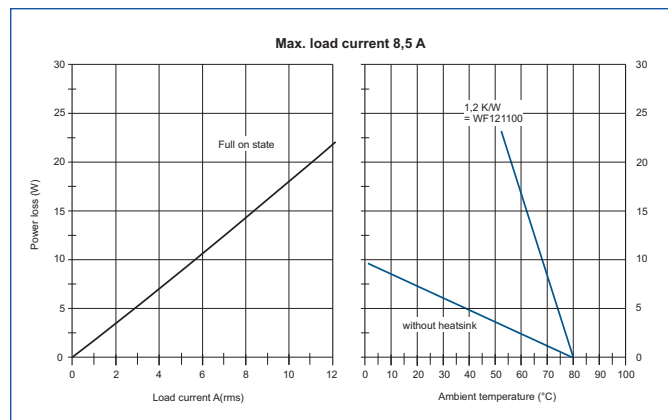

Heat sinks see on pages 32, 33 and 34

Standard panel mount package, 3-phases reversing contactor

Solid-state relay HL

Technical specifications	HL D5208R
Zero switching	Yes
Instantaneous switching-on	–
Control circuit	DC
Load circuit	AC
Load circuit	
Voltage range	24 ... 520 V
Operating frequency range	25 ... 440 Hz
Transient overvoltage	1600 V
Load current range	100 mA ... 8,5 A
Max. surge current (10 ms)	550 A
Max. off-state leakage current (rated voltage)	5 mA
Min. off-state du/dt	500 V/μs
Max. on-state voltage drop	1,4 V
Max. turn-on time	20 ms/100 ms
Max. turn-off time	10 ms
Max. I ² t for fusing (10 ms)	1500 A ² s
Thermal resistance to base	0,5 K/W
Integrated overvoltage protection	Yes
Control circuit	
Control voltage range	12 ... 30 VDC
Must release voltage	6 V
Max. reverse voltage	30 V
Typical input current at nominal voltage	15 ... 25 mA
Generalities	
Insulation input/output/base	3300/30000 Vrms
Ambient operating temperature range	-40 ... +100 °C
Ambient storage temperature range	-40 ... +100 °C
Weight (typical)	410 g
Approvals	UL
Screw torque requirements:	
M3 screws (Control circuit)	1,2 Nm
M5 screws (Load circuit)	1,8 Nm
Article number	42310141
(Order data see chapter 1)	

Accessories

Heat sink for 1- and 3-phases solid-state relays

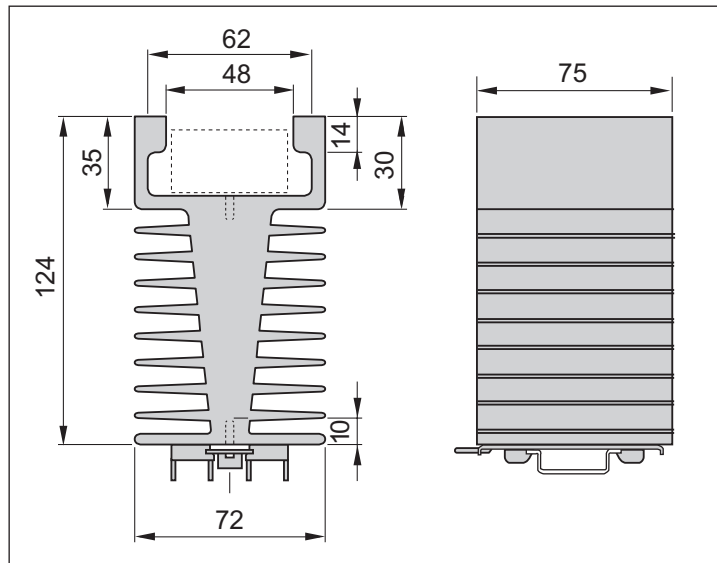
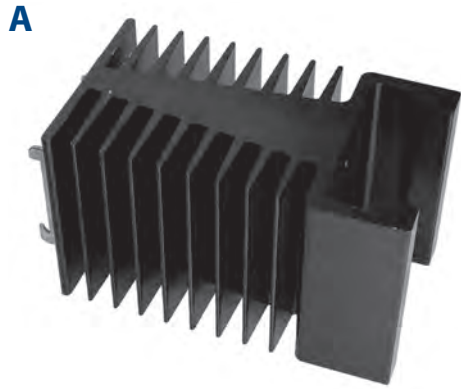

It is essential to use heat conduction foil or heat conductive paste between the solid-state relay and the heat sink.

Heat conduction foil is already applied on or supplied with all Selectron semiconductor relays!

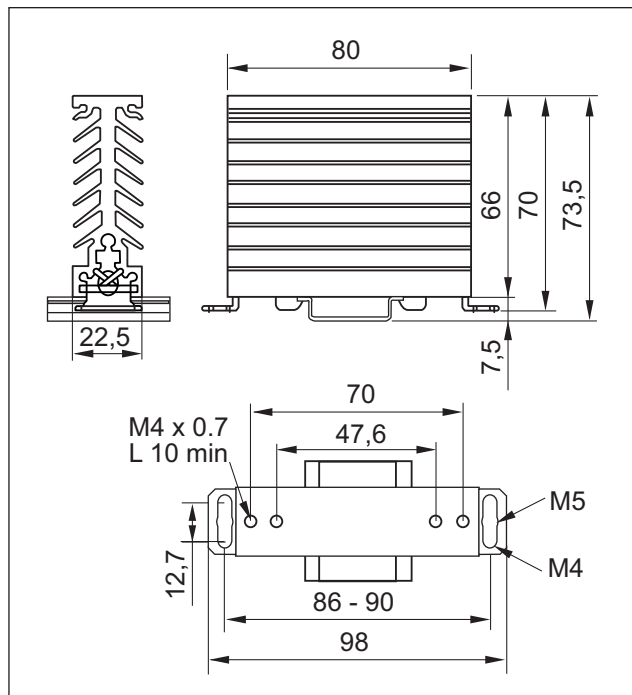

Description	Type	Dimension	Weight	Article number	
Heat sink 0,7 °C/W	HRK 0,7 C	A	915 g	41920003	
Heat sink 3,0 °C/W	HK 3,0C	B	150 g	42310300	

(Order data see chapter 1)

Accessories

Heat sink for 1- and 3-phases solid-state relays

C

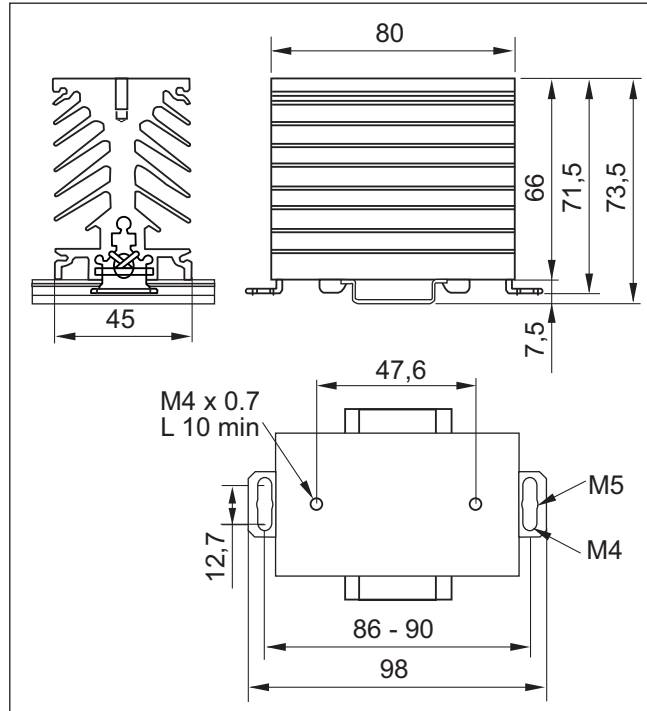

D

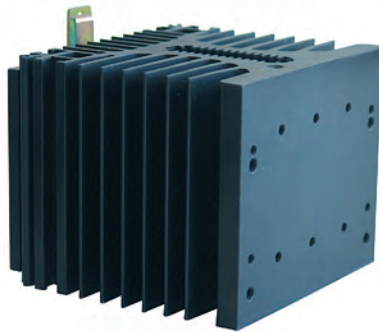

It is essential to use heat conduction foil or heat conductive paste between the solid-state relay and the heat sink.

Heat conduction foil is already applied on or supplied with all Selectron semiconductor relays!

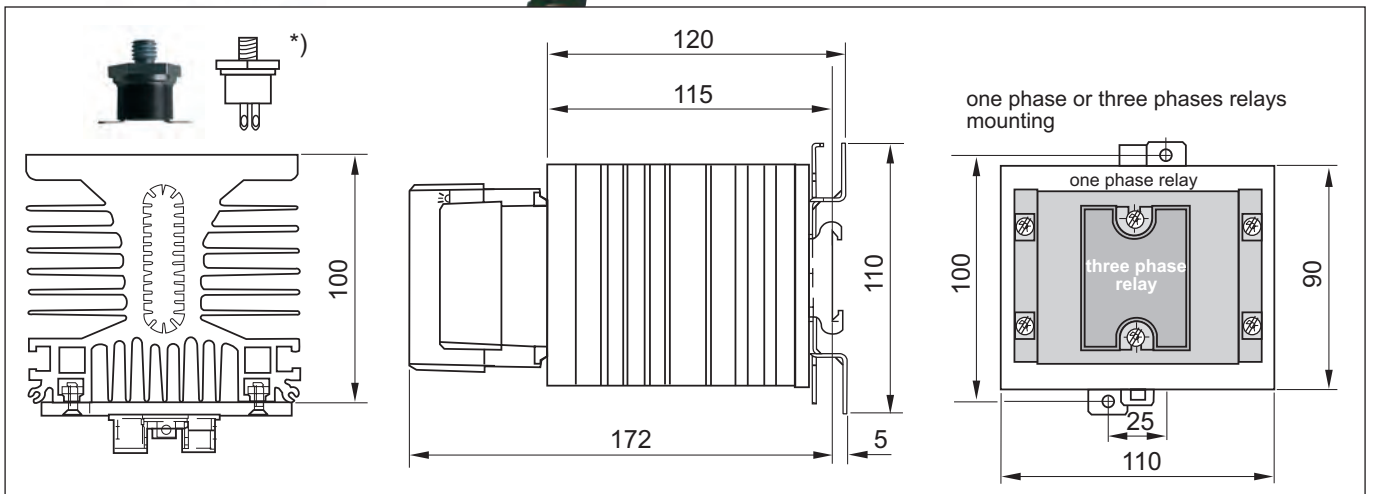

Description	Type	Dimension	Weight	Article number
Heat sink 2,2 °C/W	HK 2,2C	C	300 g	42310304
Heat sink 0,9 °C/W	HK 0,9C	D	1'400 g	42310302
*) Thermostat	TS 90 M6 for heat sink HK 0,9		10 g	42310320

(Order data see chapter 1)

Accessories

Heat sink for 1-phase solid-state relays printed circuit board mount

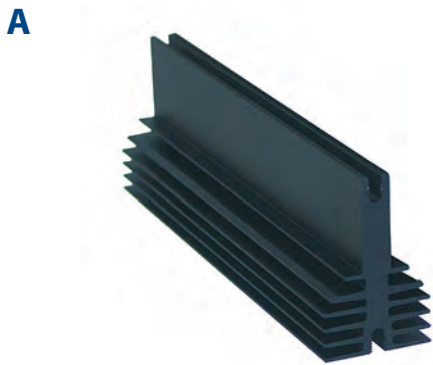

Dimension A: height x width x length 45 x 30 x 100 mm

Dimension B: height x width x length 45 x 30 x 150 mm

Mounting examples

Thermal heatsinks with clip mounting system

Heatsinks references:

HKT 3.0: L = 100 mm about 4 K/W (1 relay) without ventilation (3,6 K/W with 4 relays)

HKT 4.0: L = 150 mm about 3 K/W (1 relay) without ventilation (2,5 K/W with 6 relays)
other heatsinks on request



Clip reference : CKT K1

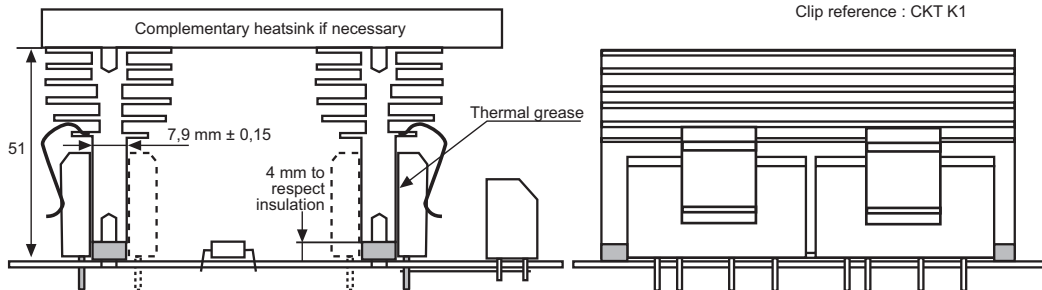

Clips with screws on standard heatsinks

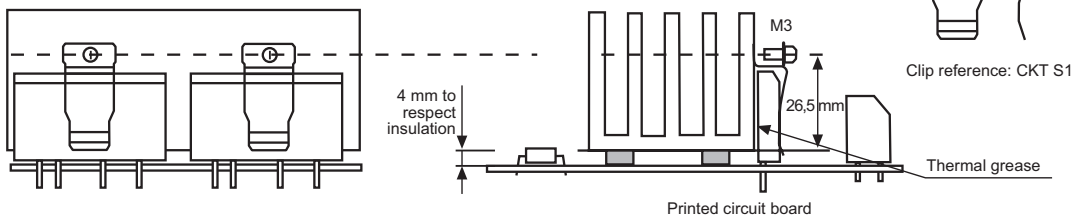

In each case, 4 mm must be respected between the printed circuit board and the heatsink, to keep a correct insulation between input and output (4 mm insulated washer).

Mind to good contact between the relay and the heatsink. Use thermal grease.

Description	Type	Dimension	Weight	Article number	
Heat sink 3,0 °C/W	HKT 3,0	B	190 g	42310306	
Heat sink 4,0 °C/W	HKT 4,0	A	130 g	42310307	
Mounting clip	CKT K1		10 g	42310310	
Mounting clip	CKT S1		10 g	42310311	

(Order data see chapter 1)

Accessories

Ventilator for 1- and 3-phases solid-state relays

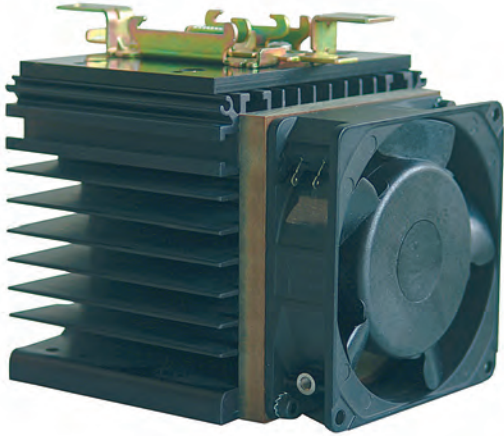

Heat sink with fan for all screw-on relays

Type	HK 0,3 LB 230
Operating voltage	230 Vac
Power consumption	9 W
Heat dissipation with HRK 0,5	0,3 °C/W
Weight without heat sink	1'770 g
Fasteningscrews for 3-phases relays are included in delivery	
Article number	42310305
(Order data see chapter 1)	

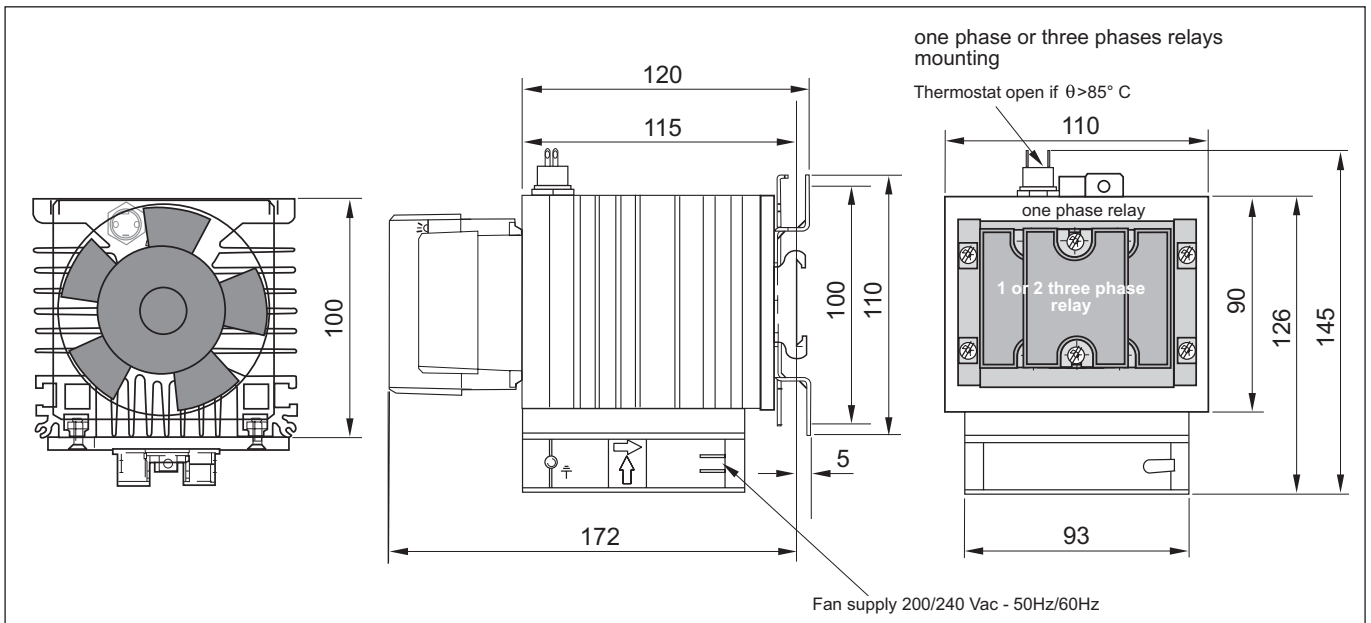

Accessories

DIN-mounting

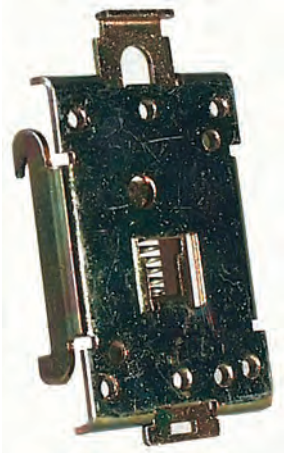

DIN-mounting DB 2

for construction HRS

(Order data see chapter 1)

Weight

60 g

Article no.

41920013

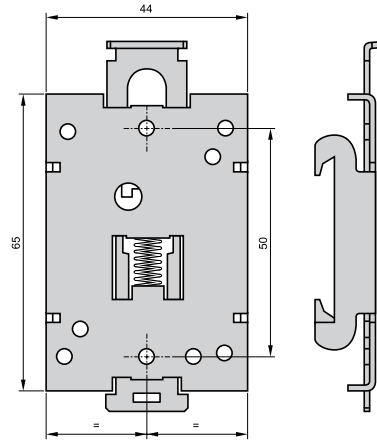

Application notes

Contact free switching in all domains

Solid state relays from Selectron Systems AG are particularly suitable for ranges where high currents have to be switched fast, such as e.g. in regard of the temperature control on heatings or where there are strong vibrations (no moving mechanical parts), or when there are heavy environmental conditions such as high humidity, extreme temperatures etc.

- Ac load voltage range up to 660Vac
- Ac load current range up to 125A
- Dc load voltage range up to 110Vdc
- Dc load current range up to 40A
- Zero cross turn-on
- Random turn-on
- Maintenance-free
- High switching frequency
- Operating temperature -55°C bis +100°C

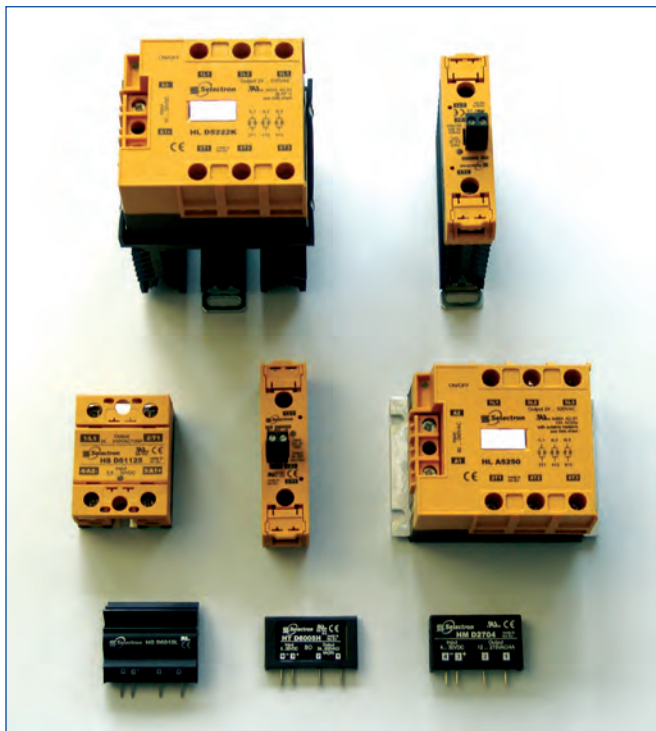

The Surface Mount Technology SMT

All relays from Selectron Systems AG are based on SMT technology. Due to an up to date equipping technique the error rates could be decisively decreased. All result in unsurpassed reliability.

SSRs exceed 2.000.000 operating hours

The reliability levels achieved through this and other refinements of manufacturing are reflected in quality assurance calculations for „observed“ mean time between failures (MTBF).

The calculation is done by estimating the number of device operating hours for a particular relay family and dividing this figure by the number of non-misapplication related field failures. A conservative assumption is used in which we assume 10% of non-misapplication related field failures are actually returned to us.

Calculated mean time between failures is, depending upon the family or type involved, between 2.000.000 and 40.000.000 operating hours.

The Test Advantage

All Selectron Systems AG SSRs are subjected to the following comprehensive series of tests (with conservative guard bands) on 100% of all products both before and after encapsulation. The quality assurance test steps are as follows:

- Verify true Kelvin sense connections for V_f measurement
- Forward voltage drop
- Blocking voltage
- Turn-on voltage (ac or dc depending on model)
- Turn-off voltage (ac or dc depending on model)
- Proper operation with resistive load
- Proper operation at 0.5 power factor, inductive load
- Leakage current at rated voltage
- Isolation voltage input-output and output-base

Technical safety advice

This manual contains the information necessary for the correct utilisation of the products described therein. It is intended for technically qualified persons who are involved as either

- planning engineers familiar with the safety concepts of automation technology;
- or, operating personnel, who have been instructed in handling automation equipment and have a knowledge of the contents of this manual concerning operation;
- or, installation and servicing personnel possessing the necessary training to repair such an automation system or who have the authority to put such circuits and equipment/systems into operation, to earth or label them according to the relevant safety standards.

The products are constructed, manufactured and tested in compliance with the relevant VDE standards, VDE specifications and IEC recommendations.

Danger warning

These warnings serve both as a guide for those persons involved in a project and as safety advice to prevent damage to the products themselves or to associated equipment.

Due to advancements in technology, the wiring diagram on the actual device may be different than shown in this catalogue. In all instances where the actual device diagram is different, the wiring diagram on the device must be used when electrical connections are made.

Correct utilisation, configuration and assembly

The equipment is to be used only for the applications stated in the catalogue and technical literature, and only in conjunction with auxiliary equipment and devices that are recommended or approved by Selectron Systems Ltd.

Further, it should be noted that:

- the automation equipment must be disconnected from any power supply before it is assembled, disassembled or the configuration modified.
- Solid state electronic switches must not be tested with incandescent lamps or connected to a load that exceeds its rating.
- trouble-free and safe operation of the products requires correct transportation as well as appropriate storage, assembly and wiring.
- the systems may only be installed by trained personnel. In doing so, the relevant requirements contained in VDE 0100, VDE 0113, IEC 364, etc. must be complied with.

Prevention of material damage or personal injury

Additional external safety devices or facilities must be provided wherever significant material damage or even personal injury could result from a fault occurring in an automation system. A defined operating status must be ensured or forced by such devices or facilities (e.g. by independent limit switches, mechanical interlocks, etc.).

Advice concerning planning and installation of the products

- The safety and accident prevention measures applicable to a specific application are to be observed.
- In the case of mains-operated equipment, a check is to be made before putting it into operation to ensure that the preset mains voltage range is suitable for the local supply.
- In the case of a 24 V supply, care must be taken to ensure sufficient electrical insulation of the secondary side. Use only mains power supply units that conform to IEC 364-4-41 or HD 384.04.41 (VDE 0100 Part 410).
- Automation systems and their operating elements are to be installed in such a way that they are sufficiently protected against accidental operation.

Warranty

Selectron Systems Ltd. warrants its products to be free from defects in material and workmanship for a period of one year from the date of shipment. All claims under this warranty must be made within thirty (30) days of the discovery of the defect, and all defective products must be returned at the buyer's expense. Buyer's sole and exclusive right will be limited to, at the option of Selectron Systems Ltd., the repair or replacement by Selectron Systems Ltd., of any defective products for which a claim is made.

In all other matters please refer to the „General terms of business“ concerning Selectron Systems Ltd.

Note

The information given in this documentation corresponds to the state of development at the time of going to press and is therefore not binding. Selectron Systems Ltd. reserves the right to make alterations in the interests of technical advancement or product improvement at any time without giving reasons for doing so.

Application notes (SSR)

General

Definition

A SSR (solid state relay) is able to perform many tasks that an EMR (electromechanical relay) can perform. The SSR differs in that it has no moving mechanical parts within it. It is essentially an electronic device that relies on the electrical, magnetic and optical properties of semiconductors, and electrical components to achieve its Isolation and relay switching function.

Over the last ten years many standards have been set regarding SSR packages, most notably the rectangular package which has now become an industry standard for power switching using SSRs, with models ranging from 1 to 125 A.

Applications

Since its introduction the SSR, as a technology, has gained acceptance in many areas, which had previously been the sole domain of the EMR or the Contactor. The major growth areas have come from Industrial Process Control applications, particularly heat/cool temperature control, motors, lamps, solenoids, valves, transformers.

The following are typical examples of SSR applications: manufacturing equipment, food equipment, security systems, industrial lighting, fire and security systems, dispensing machines, production equipment, on-board power control, traffic control, instrumentation systems, vending machines, test systems, office machines, medical equipment, display lighting, elevator control, metrology equipment, entertainment lighting.

The Advantages of the Solid State Relay

When utilised in the correct manner for the intended application, the SSR provides many of the characteristics that are often elusive in the EMR; a high degree of reliability, long service life, significantly reduced electromagnetic interference, fast response and high vibration resistance are significant benefits from SSRs.

In today's environment we have all come demands, rather than to expect, improved performance from the components that we use. The SSR offers Designers, Engineers and Maintenance Engineers significant advantages over alternative technologies, further enhanced by the use of Surface Mount Solid State circuitry.

These advantages are namely consistency of operation and longer usable lifetime. The SSR has no moving parts to wear out or arcing contacts to deteriorate, which are often the primary cause of failure within an EMR. The long term reliability of components used within SSRs has become well established throughout industry, and with no moving parts to become fractured, detached, or to resonate during operation, makes the SSR solution more robust when used in unfriendly environments.

- Zero voltage turn-on, low EMI/RFI
- Random turn-on, proportional control
- Long life (reliability) > 10⁹ operations
- No contacts - handles high inrush current loads
- No acoustical noise
- High switching frequency
- Microprocessor compatible
- Design flexibility
- Fast response
- No moving parts
- No contact bounce

In terms of internal design, the SSR and the EMR are fundamentally similar in that each has an input electrically isolated from the output that control a load. Fig. 1 shows the basic configurations of both the SSR and EMR. In the case of the SSR, the isolation is achieved by photocoupling and transformer coupling, and in the EMR by means of a magnetic coupling.

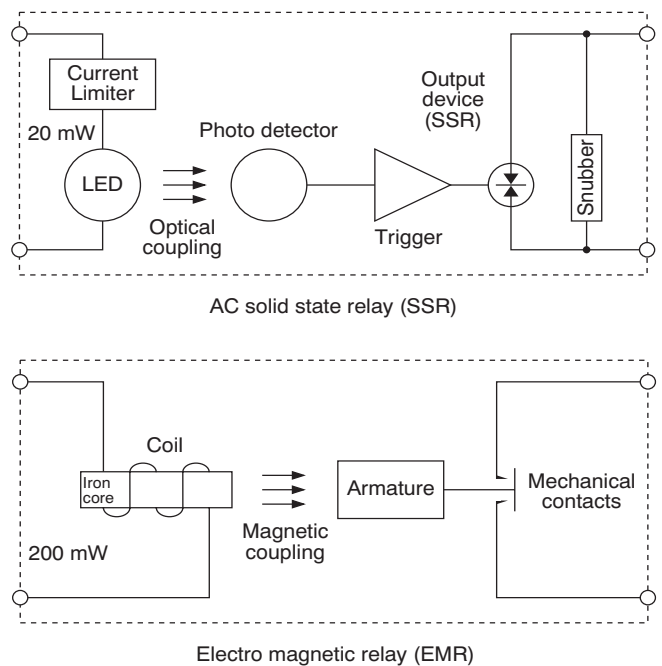

Fig. 1 Solid state relay and electromagnetic configurations

Comparing the two technologies, the input control of the SSR is functionally equivalent to the EMR, while the output device of the SSR performs the switching function of the EMR contacts.

The operating speed of the EMR is dependent upon the time it takes for its mechanical mass to react to the application and removal of a magnetic field. Operating speed of the SSR is primarily determined by the switching speed of the output device, typically much faster - microseconds for DC SSRs compared to milliseconds for EMRs. In most ac SSRs, response time is related to phase angle and frequency of the line, and

in the case of the zero voltage/current types, may be deliberately prolonged. In the case of ac input control, the operating speeds of both the EMR and SSR are similarly extended due to phase angle and filtering considerations.

SSR Operation

For a better understanding of SSRs, an SSR Operational description is included. It has to be said that an in-depth understanding of the internal circuitry of an SSR and how it functions are not in themselves a prerequisite to the use of SSR in many applications.

Most SSRs in the higher current ranges are offered with either ac or dc control options. Indeed many have some form of current limiting at their input in order to provide a practical operating voltage range.

dc inputs

Figs. 2A und 2B illustrate two typical dc input circuits for controlling current through the photocoupler LED. The low end of the input range is tailored to provide the minimum input current required to operate the SSR, at the specified turn-on (must on) voltage (typically 3 volts dc). The high end of the range by dissipation in the current limiting component (typically 32 Vdc).

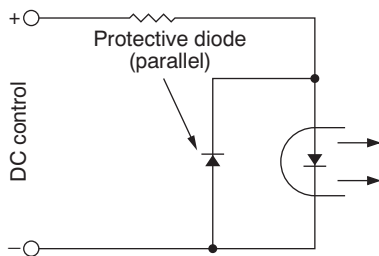

Fig. 2A Dropping resistor

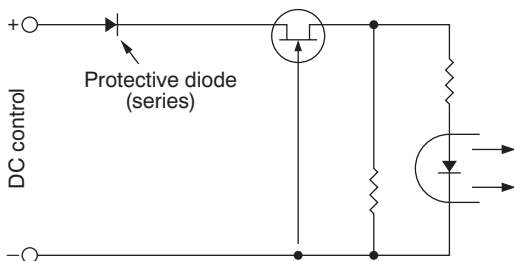

Fig. 2B Constant-current resistor

As a precaution against inadvertent voltage reversal, a series or inverse parallel diode is usually included in the input circuit. With an inverse parallel diode resistor, so brief voltage transients of a higher magnitude will not damage the diode or LED. However, the series diode is favoured because it also raises the level of voltage noise immunity by a value equal to its forward voltage drop.

ac inputs

ac inputs models are usually suitable for both 120 und 240 Vac line voltages, with a typical operating range of 90 to 280 Vac and 60 kΩ input impedance. Full wave rectification is used, followed by capacitive filtering and dropping resistors, as shown in Figs. 3A und 3B. While both circuits work equally well, the circuit in Fig. 3B is favoured as being more reliable and fail safe, since two or more components would have to fail to create an unsafe situation.

In the circuit of Fig. 3A, a single diode breakdown would place a dead short across the incoming line, thus creating a possible heat hazard.

Either of the ac input circuits in Fig. 3 is also capable of operating from a dc source and, therefore, might be considered as ac-dc; however, SSR inputs are rarely characterised in that

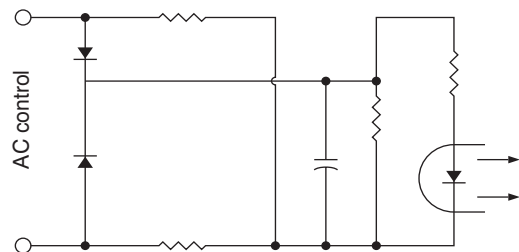

Fig. 3A: Two-diode input

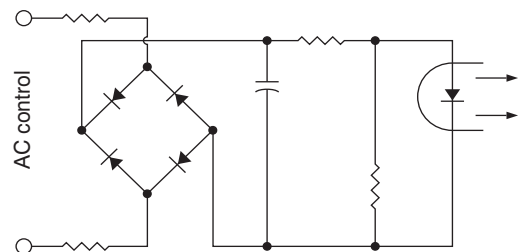

Fig. 3B: Bridge input

way. The circuit of Fig. 3B should operate with a dc control range similar to that of the ac (RMS) source. On the other hand, the circuit of Fig. 10A might have dissipation problems with the input resistors, since they would no longer operate at a 50% duty cycle. In both cases, the SSR would have the uniqueness of operating from a dc signal of either polarity.

Well designed ac input-output SSRs can operate from separate power sources operating at different frequencies, as long as they are both within the specified limits of voltage, frequency and isolation. Line frequency for both input and outputs is typically specified as 47 to 63 hertz, the upper limit of which is not critical for the input control power since the input is rectified and filtered. However, the upper frequency limit for an output is less flexible, especially for a triac, which has definite limitations, related to its ability to commute off. An SCR output pair is capable of operating at much higher frequencies. However, because of circuit time constraints in the drive circuitry, other SSR parameters become the limiting factors (e.g. the zero switching window may be extended and/or turn-delayed each half cycle with eventual lock.on or lockout).

Zero switching

Zero voltage turn-on (or zero crossing), as illustrated in Fig 4, is used in some ac SSRs to reduce electromagnetic interference and high inrush currents. Without zero crossing, the load voltage is applied randomly to the load at any point in the line voltage cycle.

With the zero crossing feature, the line voltage is switched to the load only when it is close to zero, typically specified with a maximum value of ± 15 volts peak. Thus, a very small change in power results, and proportionally lower EMI levels are generated. After zero crossing, the „Zero“ switching voltage, which defines the switching window limits, may also be expressed in terms of phase angle, or time, converted as follows:

Voltage to phase angle (15 volts) or phase angle to time (5°):

$$\phi = \sin^{-1} \frac{Z \text{ sw. max.}}{\text{Line V RMS } (\sqrt{2})} \quad T = \frac{\frac{1}{2} \text{ cyc. ms}}{\frac{1}{2} \text{ cyc. deg}} \times \phi$$

$$\phi = \sin^{-1} \frac{15}{120 \times 1,41} \quad T = \frac{8,3}{180} \times 5$$

$$\underline{\underline{\phi = 5^\circ}} \quad \underline{\underline{T = 0,23 \text{ ms}}}$$

Zero voltage turn-off is an inherent characteristic of the thyristors used in ac SSRs, whether zero voltage is employed or not. Once triggered, the thyristor stays on for the balance of the half cycle, until switching load current drops below its „holding“ level, where it turns off. For a resistive load, this point is also close to zero voltage, as shown in Fig. 5. With an inductive load, the amount of stored energy in the load is a function of the current flowing through it, which in this case is so small that inductive kickback is virtually eliminated. This is probably the most desirable feature of the SSR, when compared to the destructive effects of „arcing“ contacts when switching inductive loads with an EMR.

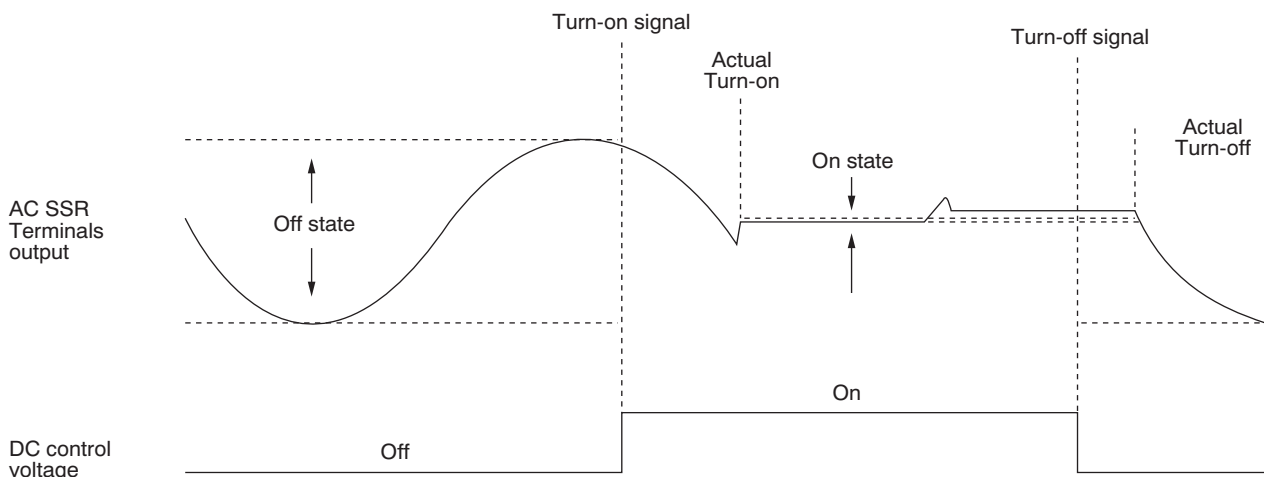

Fig. 4: Zero voltage turn-on

Solid State Relay characteristics

Systems offers an extensive range of Solid State Relays in various package styles, mounting options, terminal types and switching capability.

Selecting the ideal SSR

In a bid to specify the exact SSR for an application, it is important to consider the:

- input drive requirement
- output current
- load or output current
- the isolation and installation requirements

In many instances the load power will dictate whether the SSR is PCB, panel, or DIN rail mounted. In loads higher than 5 to 7 amps, a heat sink becomes necessary to remove heat from the SSR body. Certain SIG Positec Systems designs include integral heat sinks, while others have dissipation characteristics that are inherently within the products.

Driving the SSR

To activate an SSR output, a voltage greater than that specified for maximum turn-on is applied to the input (3 volt dc typical). The off state occurs when zero or less than the minimum turn-off voltage is applied (1 volt dc typical). For an AC input type, the typical values would be 90 volts RMS for on, and 10 volts RMS for off. For an SSR designated as normally closed or form B, the previous on-off conditions would be reversed. Generally, normally open is the accepted, but undesignated, standard for the SSR.

dc is considered as being a steady-state dc voltage of one polarity, and ac is a reasonably well shaped sinusoidal waveform. Due to consideration of input to output isolation, the switch controlling the input to an SSR can be placed in series with either of the two input terminals, assuming polarity is observed (dc). The same flexibility applies to the output side, where the load may also be placed in series with either output terminal. There are a few specialised types, usually with more than two input or output terminals, that have dedicated functions (i.e. Vcc logic input and common).

The activating signal may be derived from mechanical contacts or solid state devices such as those shown in figure 6. The minimum supply voltage through these contacts may be equal to the SSR turn-on voltage (3 volts dc typical), whereas the positively or negatively referenced transistors require a minimum supply voltage a few tenths of a volt above the specified turn-on threshold, say 3.5 volts

dc. This is because of their approximate 0.2-0.4 volt on state voltage drop when driven in the grounded emitter (saturating) mode.

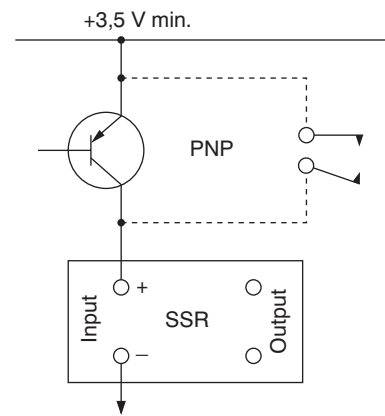

Fig. 5A: PNP transistor

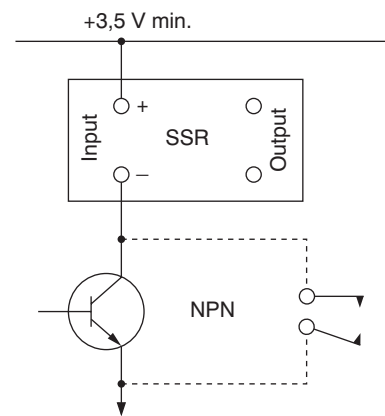

Fig. 5B: NPN transistor

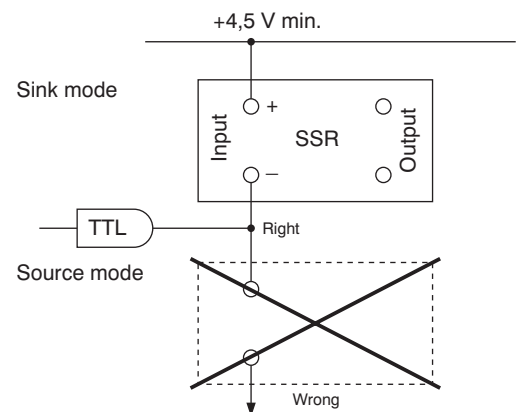

Fig. 5C: TTL gate

TTL drive methods

A standard TTL gate can drive most SSRs with its 16 mA sink capability. However, very few SSRs can be driven reliably with the gates' available source current of only 400 µA. Also, the SSR minimum voltage threshold requirements are not met in the source mode (i.e. gate output in the positive leg of the SSR).

The relationship of the TTL gate to an SSR is illustrated schematically in Fig. 6. In this configuration the SSR supply voltage and the gate Vcc should be common and comply with the TTL specified limits of say 5 volts +/- 10%. It can be seen that with a positively referenced SSR and the gate at logical (0), Q2 is operating much like a discrete NPN transistor in the grounded-emitter saturated state. In this mode the gate can

which is 0.6 volt below the SSR turn-on threshold (assuming a 3 volt turn-on). Although some SSRs may operate satisfactorily in this mode, it is not recommended that this be done. Both the available current and the minimum voltage are considered inadequate for the typical optically isolated SSR.

It should be noted that the 2,4 volt gate output in the logical 1 state relates only to a negatively referenced load. It does not represent a voltage source to a positively referenced load (SSR), where it would appear to be greater than the off state voltage. Referring again to Fig. 6, Q2 would be off and CR1 is reverse biased, thus presenting essentially an open circuit with virtually zero potential across the SSR.

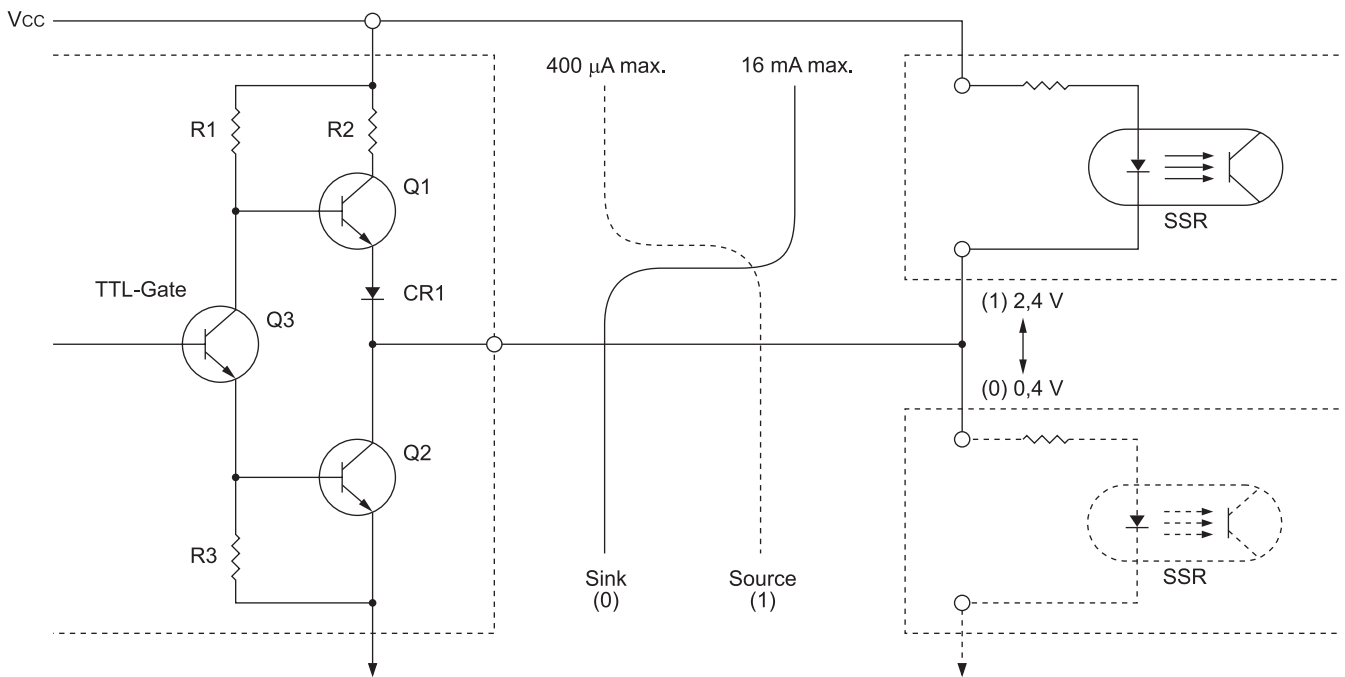

Fig. 6: Typical circuit of a TTL gate driving SSR

sink up to 16 mA with a maximum 0.4 volt drop. Subtracting 0.4 volt from the worst case Vcc of 4.5 volts, a minimum of 4.1 volts will appear across the SSR input terminals, which is sufficient to turn on most SSRs. For different supply voltage tolerances, the values would be adjusted accordingly.

With a negatively referenced SSR and the gate at logical (1), Q1 conducts, but does not saturate, since it is operating as an emitter follower (common collector). In this mode the gate can source up to 400 microamps; however, the accumulated voltage drops are:

$$R1(I_{R \text{ Drop}}) + Q1V_{BE} + CR1V_F$$

The sum of these values subtracted from the worst case Vcc results in a minimum output voltage specified as 2.4 volts,

IC and other drive sources

Most CMOS and NMOS logic families will not directly interface with SSRs, except for a few specially designed types. However, a CMOS buffered gate can reliably drive an SSR that has low input power requirements (i.e. >1500 ohms at 5 volts) and is also driven in the sink mode the same as TTL.

Fig. 7 shows 1/6 of 4049 (inverting) or a 4050 (non-inverting) CMOS hex buffer driving such an SSR with a common 5 volt supply. CMOS can, of course, operate at higher voltages, but care must be taken not to overstress the gate with excessive dissipation.

Integrated circuits with open collector outputs are also commonly used to drive SSRs, as in Fig. 8. The open collector IC has an output transistor without an active (transistor) or

passive (resistor) pull-up and generally has enough power to drive an SSR directly. Open collector outputs can also be logically ORed like discretes, so that the SSR may be controlled by any one of the many outputs. Furthermore, the SSR supply voltage does not have to be the same as the IC Vcc, provided that one side is common and the transistor and SSR maximum voltages and currents are not exceeded.

SSRs do not generally require pull-up or shunt resistors for noise reduction or any other functional reason. An open input, if not assigned to a particular logic level, produces an open or off state in the output (unless otherwise designated). Input lines would have to be extremely long and through noisy environments before noise of any significance would appear at the input terminals to cause the SSR to change state.

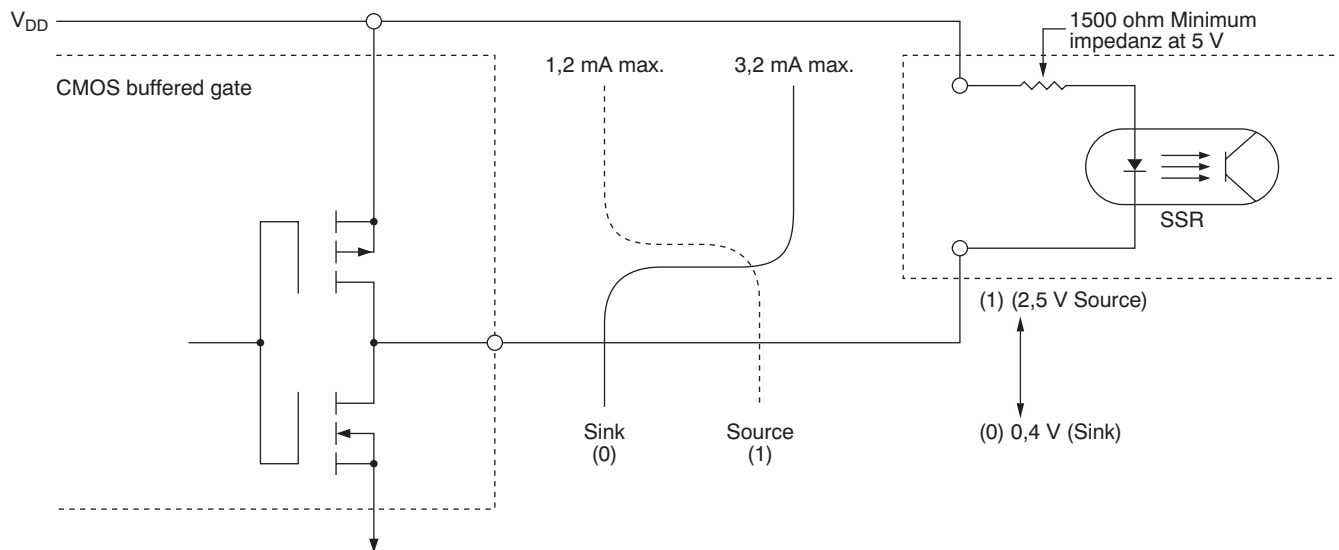

Fig. 7: Buffered CMOS gate driving a high input impedance SSR

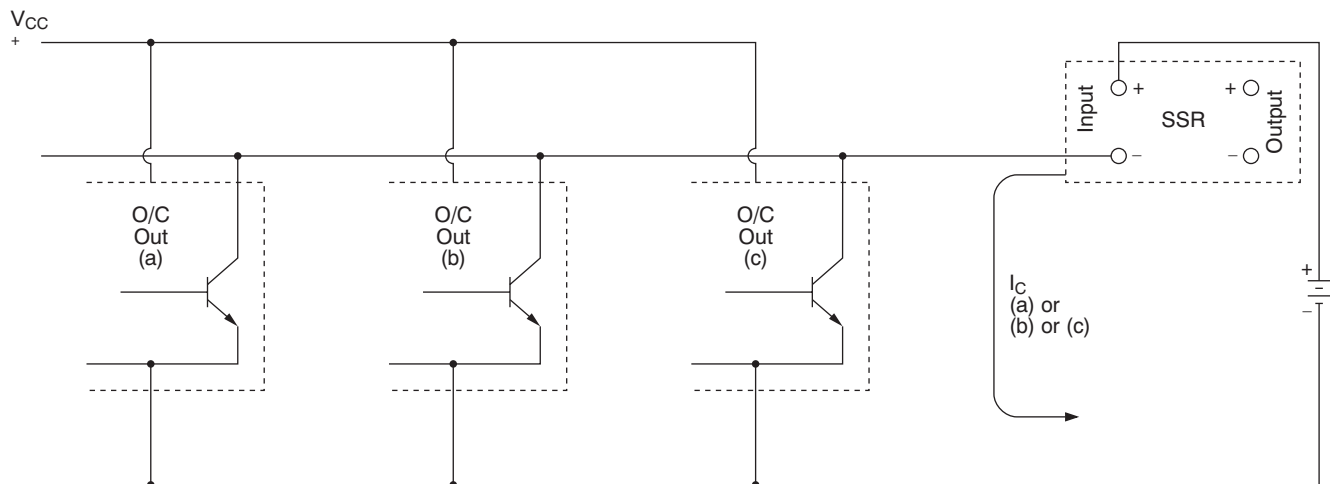

Fig. 8: Open collector IC driving SSR in logically ORed configuration

Leakage from the drive source

The off state leakage current in the driving semiconductors shown in Figs. 6 to 8 is significant, just a few microamperes, which could not possibly turn on the SSRs. However, the off state (output leakage current of any packaged solid state driving device (e.g. temperature controller, etc.) should first be checked for compatibility with the SSR.

One method is to multiply the maximum leakage current (amps) by the maximum input impedance (ohms) of the SSR. This should result in a voltage that is less than the specified turn-off voltage. If it is not, a resistive shunt across the SSR input may be required.

Thermal considerations

One of the major considerations when using a SSR, is that an effective method of removing heat from the SSR package must be employed. SSRs have a relatively high „contact“ dissipation, in excess of 1 watt per amp. Usual methods for heat dissipation are cooling by flowing air or forced airflow around the SSR or the application of heat sink.

With loads of less than 5 amps, cooling by free flowing air or forced airflow around the SSR is usually sufficient. At higher currents it will become necessary to make sure the radiating surface is in good contact with a heat sink. Essentially this involves mounting the base plate of the SSR onto a good heat conductor, usually aluminium; good thermal transfer between the SSR and the heat sink can be achieved with thermal grease or heat sink thermal resistance ($R_{\theta CS}$) is reduced to a negligible value of 0,1°C/W (celsius per watt) or less. The simplified thermal model in Fig. 9 indicates the basic elements

to be considered in the thermal design. The values that are determinable by the user are the case to heat sink interface ($R_{\theta CS}$), as previously mentioned, and the heat sink to ambient interface ($R_{\theta SA}$).

Thermal calculations

Fig. 9 illustrates the thermal relationships between the output semiconductor junction and the surrounding ambient. $T_J - T_A$ is the temperature gradient or drop from junction to ambient, which is the sum of the thermal resistances multiplied by the junction power dissipation (P [watts]).

Hence:
$$T_J - T_A = P (R_{\theta JC} + R_{\theta CS} + R_{\theta SA})$$

whereas:

- T_J = Junction temperature, [°C]
- T_A = Ambient temperature, [°C]
- P = Power dissipation ($I_{LOAD} \times E_{DROP}$), [W]
- $(R_{\theta JC})$ = Thermal resistance, junction to case, [°C/W]
- $(R_{\theta CS})$ = Thermal resistance, case to sink, [°C/W]
- $(R_{\theta SA})$ = Thermal resistance, sink to ambient, [°C/W]

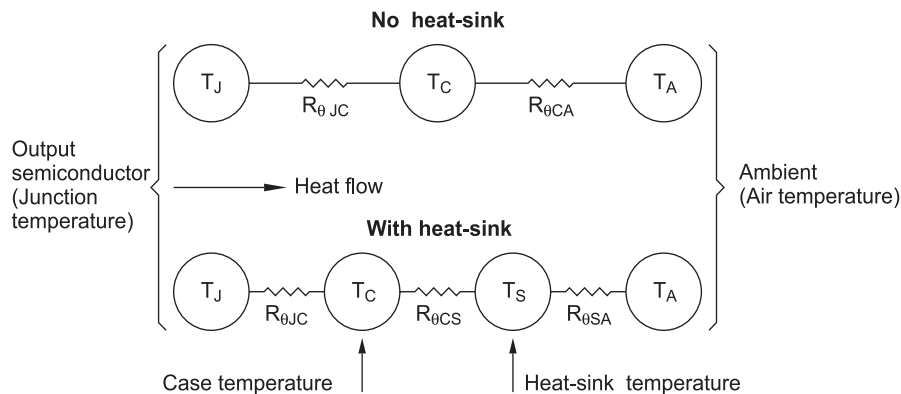

Fig. 9: A simplified thermal model

To use the equation, the maximum junction temperature must be known, typically 125°C, together with the actual power dissipation, say 12 watts for a 10 amp SSR, assuming a 1,2 volt effective (not actual) voltage drop across the output-semiconductor. The power dissipation (P watts) is determined by multiplying the effective voltage drop (E_{DROP}) by the load current (I_{LOAD}).

Assuming a thermal resistance from junction to case of say, 1,3°C/W and inserting the above typical values (R_{θCS}) into the equation, solutions can be found for unknown parameters, such as maximum load current, maximum operating temperature, and the appropriate heat sink thermal resistance.

Where two of these parameters are known, the third can be found as shown in the following examples:

(a) To determine the maximum allowable ambient temperature: Heat sink = 1°C/W, Load = 10 A (12 W), T_{J-max.} = 100 °C

$$T_J - T_A = P (R_{\theta JC} + R_{\theta CS} + R_{\theta SA}) \quad \text{hence,} \quad T_A = T_J - 28,8$$

$$T_J - T_A = 12 (1,3 + 0,1 + 1,0) \quad T_A = 100 - 28,8$$

$$\underline{\underline{T_J - T_A = 28,8}} \quad \underline{\underline{T_A = 71,2 \text{ }^\circ\text{C}}}$$

(b) To determine required heat sink thermal resistance: Maximum ambient temperature = 71,2 °C, Load = 10 A (12 W):

$$R_{\theta SA} = \frac{T_J - T_A}{P} - (R_{\theta JC} + R_{\theta CS})$$

$$R_{\theta SA} = \frac{100 - 71,2}{12} - (1,3 + 0,1)$$

$$\underline{\underline{R_{\theta SA} = 1 \text{ }^\circ\text{C/W}}}$$

(c) To determine maximum load current: Heat sink = 1 °C/W, ambient temperature = 71,2 °C:

$$P = \frac{T_J - T_A}{R_{\theta JC} + R_{\theta CS} + R_{\theta SA}} \quad \text{hence,} \quad I_{\text{Load}} = \frac{P}{E_{\text{Drop}}}$$

$$P = \frac{100 - 71,2}{1,3 + 0,1 + 1,0} \quad I_{\text{Load}} = \frac{12}{1,2}$$

$$\underline{\underline{P = 12 \text{ W}}} \quad \underline{\underline{I_{\text{Load}} = 10 \text{ A}}}$$

Regardless of whether the SSR is used on a heat sink or the case is cooled by other means, it is possible to confirm proper operating conditions by making a direct base plate temperature measurement when certain parameters are known. The same basic equation is used except that base plate temperature (T_C) is substituted for ambient temperature (T_A) and R_{θCS} and R_{θSA} are deleted. The temperature gradient now becomes T_J - T_C, that is the thermal resistance (R_{θJC}), multiplied by the junction power dissipation (P watts). Hence:

$$T_J - T_C = P (R_{\theta JC})$$

Parameter relationships are similar in that solutions can be found for maximum allowable case temperature, maximum load current, and required junction to case (R_{θJC}) thermal resistance. Again, where two parameters are known, the third can be found as shown in the following examples (using previous values):

(d) To determine maximum allowable case temperature for R_{θJC} = 1,3 °C/W and Load = 10 A (12 W):

$$T_J - T_C = P (R_{\theta JC}) \quad \text{hence,} \quad T_C = T_J - 15,6$$

$$T_J - T_C = 12 \times 1,3 \quad T_C = 100 - 15,6$$

$$\underline{\underline{T_J - T_C = 15,6}} \quad \underline{\underline{T_C = 84,4 \text{ }^\circ\text{C}}}$$

(e) To determine maximum load current for R_{θJC} = 1,3 °C/W and case temperature = 84,4 °C:

$$P = \frac{T_J - T_C}{R_{\theta JC}} \quad \text{hence,} \quad I_{\text{Load}} = \frac{P}{E_{\text{Drop}}}$$

$$P = \frac{100 - 84,4}{1,3} \quad I_{\text{Load}} = \frac{12}{1,2}$$

$$\underline{\underline{P = 12 \text{ W}}} \quad \underline{\underline{I_{\text{Load}} = 10 \text{ A}}}$$

(f) To determine required thermal resistance (R_{θJC}) for 84,4 °C case temperature and 10 amp load (12 watts):

$$R_{\theta JC} = \frac{T_J - T_C}{P}$$

$$R_{\theta JC} = \frac{100 - 84,4}{12}$$

$$\underline{\underline{R_{\theta JC} = 1,3 \text{ }^\circ\text{C/W}}}$$

In the examples (a) through (c) SSR operating conditions are determined as they relate to ambient air temperature using a heat sink. Similarly, conditions can be determined for an SSR operating in free air without a heat sink, provided that a value is given for the radiating characteristics of the package ($R_{\theta CA}$). This value is rarely given and when it is, it is more commonly combined with ($R_{\theta JC}$) and stated as ($R_{\theta JA}$). The equation would appear as follows:

$$T_J - T_A = P (R_{\theta JC} + R_{\theta JA})$$

or

$$T_J - T_A = P (R_{\theta JA})$$

where:

- ($R_{\theta CA}$) = Thermal resistance, case to ambient, [$^{\circ}\text{C}/\text{W}$]
- ($R_{\theta JA}$) = Thermal resistance, junction to ambient, [$^{\circ}\text{C}/\text{W}$]

The equation can be used to calculate maximum load current and maximum ambient temperature as before. However, the resultant values are inclined to be less precise due to the many variable that affect the case to air relationship (i.e., posi-

tioning, mounting, stacking, air movement, etc).

Generally, free air performance is associated with PCB or plug-in SSRs of 5 amps or less, which have no metallic base to measure. The question is often raised as to where the air temperature is measured. There is no clear-cut answer for this. Measurement is made more difficult when the SSRs are closely stacked, each creating a false environment for its neighbour. One suggested approach is to place a temperature probe or thermocouple in the horizontal plane approximately 1 inch away from the subject SSR. This technique is reasonably accurate and permits repeatability.

Ratings

The free air performance of lower powered SSRs is usually defined in the catalogue by means of a single derating curve, current versus ambient temperature based on the foregoing formulas, which is adequate for most situations.

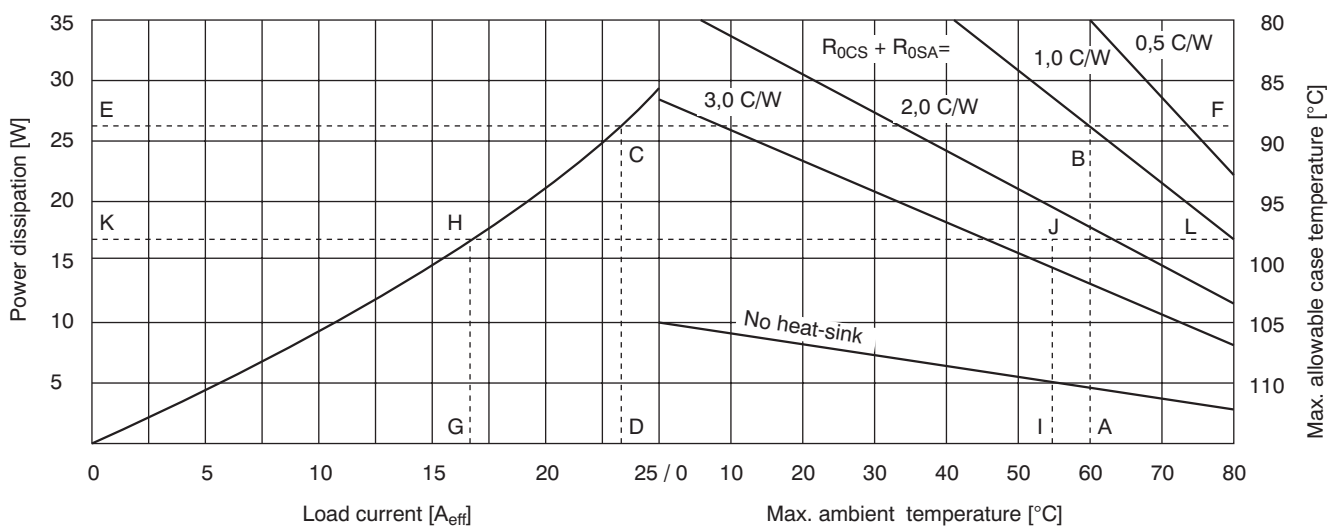

Fig. 10: Thermal derating curves

Surge ratings and high inrush current loads

After improper heat sinking, surge current is one of the more common causes of SSR failure. Overstress of this type can also seriously impair the life of the SSR. Therefore, in a new application it would be wise to carefully examine the surge characteristics of the load.

There are very few completely surgeless SSR loads. Resistive loads, such as heating elements and incandescent lamps, can prove problematic. Capacitive loads can also prove equally problematic because of their initial appearance as short circuits. High surge currents can occur while charging, limited only by circuit resistance. Inductive loads, on the other hand, tend to impede high inrush currents, in fact, inductance is often inserted into a circuit for the express purpose of limiting high fast rising peak currents (e.g. EMI filters, chokes, etc.). However, inductive loads can give rise to high inrush currents. Inductive loads have traditionally created more problems on turn-off rather than turn-on due to stored energy and „back EMF“. The inherent zero current turn-off characteristics of thyristors used in ac SSRs is most beneficial in this regard.

Surge ratings

The highest surge current rating (As) of an SSR is typically 10 times the steady-state RMS value, and it is usually given as the maximum nonrepetitive peak current for one line cycle. It should be noted that a surge of this magnitude is allowable only 100 times during the SSR lifetime. The preceding cautionary notes would tend to reduce the attractiveness of the high surge capability (100%) of the ac SSR; however, they apply only to the extreme limits where the SSR should not be designed to operate anyway. When a reasonable surge safety margin is used, conditions rapidly improve.

Generally, dc SSRs do not have an overcurrent surge capability, since the output transistors (non regenerative) are usually rated for continuous operation at their maximum capacity. The tendency is for the dc SSR to cut off (current limit), thus impeding the flow of excessive current. However, the resultant over-dissipation may destroy the relay if the surge is prolonged. If overcurrent carrying capacity is required, as may be the case when designing fuse protection, the SSR could be over specified (have a higher current capability).

To aid in the proper design of SSR fusing, an I²t rating is usually given. This parameter expressed in A²s is useful since it can relate directly to the published fuse characteristics.

It is generally derived from the peak surge (one cycle) output thyristor ratings as follows:

where:

$$I^2 t = \frac{I_{PK}^2 t}{2}$$

- I = peak surge current – (sinusoidal)
- t = duration of surge (normally 8,3 μs)
(0,0083 seconds in the formula)

For example, for a 25 amp SSR with a 250 amp one-cycle surge rating, the value would be 260 A²s.

Inductive loads

High inrush lamp and capacitive loads sometimes include a series inductor such as a choke or transformer.

This will tend to limit the initial inrush current, but the combination will primarily be seen by the SSR as an inductive load. While most SSR loads, even lamps, include some inductance, its effect with resistive loads is usually negligible. Only those loads that utilize magnetics to perform their function, such as transformers and chokes, are likely to have any significant influence on SSR operation.

The majority of SSRs will operate inductive loads with power factors as low as cosφ 0,3, especially if they are switching medium to high current loads relative to their rating. SIG Positec Systems relays are 100% tested for operation at cosφ 0,5. When a load is so light that its rating is close to the minimum current rating of the SSR, the off state leakage may become significant when compared to the load current. The leakage may have a deleterious effect on certain loads such as small solenoids that fail to drop out, or motors that buzz or even continue to run. The solution is to reduce the load impedance by means of a shunt or parallel impedance, thus reducing this voltage below the drop out or off threshold of the load.

A saturating inductive load can also cause switching problems with the SSR. The ac impedance of such a load is relatively high under normal conditions. However, when saturation occurs the inductance falls to a very low value, resulting in a fall in impedance close to that of the Copper resistance of the coil winding. This can cause several cycles of surge currents in excess of 30 times the steady-state value, which may seriously affect the lifetime.

Transformer switching

Extremely high current surges are commonly associated with transformers, especially those with a penchant for saturation. The zero voltage turn-on feature of standard SSRs can increase this possibility and might require that special precautions be taken.

At the instant turn-on, transformer current is essentially zero, with the highest peak usually occurring within a half cycle, depending on the line phase angle, load power factor, and magnetic state of the core. When the SSR is energized at the ideal phase angle, as dictated by power factor, a maximum back EMF is generated that will tend to counter the magnetizing current, thereby reducing or eliminating the surge.

However, when switched on at, or near, zero voltage, the back EMF is reduced, allowing an increase in magnetizing current that can be further enhanced by residual magnetism in the core which almost always exists since ferromagnetic core material has a natural tendency to remain magnetized at turn-off.

If a random turn-on SSR is used to switch transformer load, the likelihood of transformer core saturation is greatly reduced.

Switching

Dynamic loads, such as motors and solenoids, etc., can create special problems for SSRs, in addition to those discussed for passive inductors. High initial surge current is drawn because their stationary impedance is usually very low. For example, after the initial surge, a solenoid core will pull in and „seal“ at a much lower steady-state current, possibly by dropping to less than 25%. With motors, the change in current from stall to run can be even greater, possibly dropping to less than 20%, depending on the type.

As a motor rotor rotates, it develops a back EMF that reduces the flow of current. This same back EMF can also add to the applied line voltage and create „overvoltage“ conditions during turn-off. Mechanical loads with a high starting torque or high inertia, such as fans and flywheels, will, of course, prolong the start-up surge period, which should be taken into account when selecting the driving SSR. When the mechanical load is unknown, as may be the case with a power tool, worst case conditions should apply.

The inrush current characteristic of tungsten filament (incandescent) lamps is somewhat similar to the surge characteristic of the thyristors used in ac SSR outputs, making them a good match. The typical ten times steady-state ratings which apply to both parameters from a cold start allow many SSRs to switch lamps with current ratings close to their own steady-state ratings. Some lamps have even higher instantaneous inrush currents. This is rarely seen in practice, since line and source impedances and filament inductance become significant at higher currents, all of which tend to limit the peak current. Generally the ten times steady-state rating is considered a safe number for lamps.

Protective measures

Electromagnetic compatibility

Noise, or more properly defined as Electromagnetic Interference (EMI), does not generally cause SSRs to fail catastrophically. Some of the techniques used to reduce noise in the coupler and drive circuits are also effective against false triggering caused by voltage transients on the input lines. When a capacitor is added, for example, the response time which is not critical for ac SSRs may be lengthened, possibly from a few microseconds to tenths of milliseconds. Due to the induced delay, voltage transients or bursts of shorter duration are rejected, thus improving noise immunity.

Most ac SSRs use thyristors in their drive and output circuits which, due to their regenerative nature, can latch on for a whole half cycle when triggered by a brief voltage transient, thus acting as a pulse stretcher. In addition to responding to the amplitude of the transient, a thyristor can also mistrigger when the rate of rise (dv/dt) of a transient or applied voltage exceeds certain limits. Transient suppressors are effective against the former, and the RC snubber improves the tolerance of an SSR to the latter.

du/dt (Rate effect)

The expression du/dt defines a rising voltage versus time expressed in volts per microsecond (V/μs). When applied to an ac SSR as "static" or "off state" du/dt, it is a parameter that defines the minimum dv/dt withstand capability of the SSR or, in other words, the maximum allowable rate of rise of voltage across the output terminals that will not turn on the SSR (typically 500 V/μs).

Snubber

The internal RC network (snubber) used in ac SSRs is a major factor in transient voltage and dv/dt suppression. It deals effectively with two facets of a voltage transient. Not only does the network slow down the rate of rise as seen by the output thyristors and sensitive drive circuits, but it also limits the amplitude to which it can rise. While the typical internal snubber value and the typical dv/dt specification are adequate for most applications, they may not prevent what is commonly referred to as the „blip“ or „bleep“ problem which occurs during start-up. That is, when power is initially applied to the SSR/load combination usually by means of a mechanical switch, the resultant fast rising transient may mistrigger the SSR and possibly „let through“ a half cycle pulse, fortunately, most loads are not troubled by this pulse.

Suppressors

When overvoltage transients occur, another form of suppression may be required beyond the capabilities of the snubber. One popular technique is to add a clamping device across the SSR terminals that will absorb the transient energy above a predetermined level.

Devices, such as zeners and MOVs, will conduct only at the predetermined level and above, thereby sharing the transient with the load. If it is unacceptable for the load to receive any transient energy, the only solutions may be suppression of the transient source, or an SSR with a blocking capability higher than the transient.

Fig. 11 illustrates typical methods of suppressing transients across the SSR output „contacts“ as well as suppression of transients at the source which can be the load itself for dc inductive type loads.

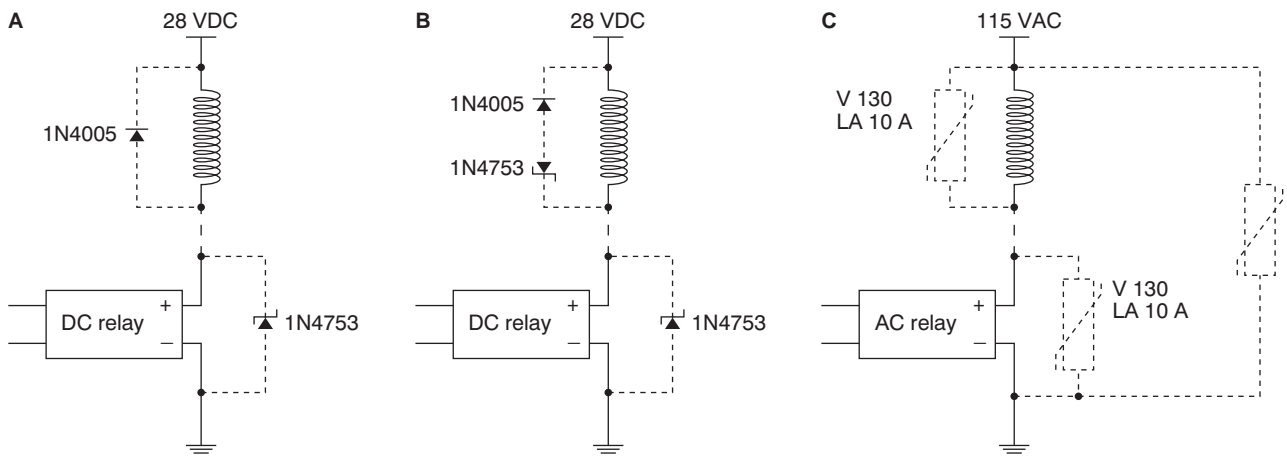

Fig. 11: Transient suppression techniques

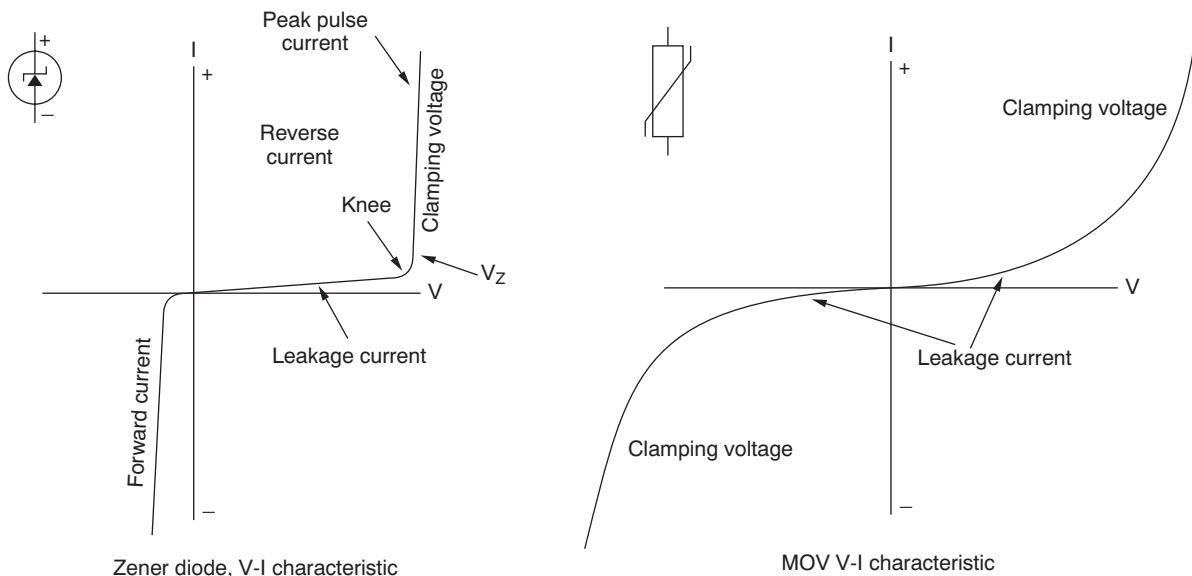

Fig. 12: Comparison of zener diode and MOV characteristics

Diodes and Zeners

The diode shown across the load in A of Fig. 12 is the most effective way of suppressing the possibly hundreds of volts of back EMF that can be generated by the coil at turn-off. The disadvantages of this method are the SSR is not protected from other transient sources, and the dropout time of the load may be extended by several milliseconds.

The general rule in the selection of protective diodes and zeners is that their peak nonrepetitive (pulse) current ratings (Fig. 12) should be equal to, or greater than, the minimum load current. Conservative steady-state power ratings for these devices may be ascertained from the following equation:

where:

$$P_{\text{Watts}} = \frac{I_L^2 L}{t_r}$$

I_L = Load current in dc Amperes

L = Load inductance in Henry

t_r = On/Off repetition rate in seconds

Example: A load with a resistance of 4 ohms and an inductance of 0.0025 henry is driven from a 28 volt dc supply while being switched on and off 5 times a second:

$$I_L = \frac{28 \text{ volts}}{4 \text{ ohms}} \quad t_r = \frac{1}{5} \quad P = \frac{7^2 \times 0,0025}{0,2}$$

$$\underline{I_L = 7 \text{ amperes}} \quad \underline{t_r = 0,2 \text{ second}} \quad \underline{P = 0,613 \text{ watt}}$$

A protective diode or zener with a ¾ watt rating would suffice.

The zener diode is the ideal choice for protecting low voltage dc SSRs (less than 100 volts dc) used in parallel with the output. In the forward current mode (reverse for the SSR), the zener diode typically clamps as a single diode would at approximately one volt, thereby providing added reverse-voltage protection. When two zeners are used back-to-back (in series) with equal stand-off voltages, they can be used to protect SSR outputs bidirectionally when switching ac loads. At higher voltages (greater than 100 volts) ac or dc, economics versus performance may suggest another transient protective device such as the MOV (metal oxide varistor) being the most popular.

MOVs (Metal Oxide Varistors)

For more hostile environments, the MOV can be used as follows:

across the incoming line to suppress external transients be-

fore they can enter the system;

across the load to suppress load generated transients; or, more frequently, across the SSR to protect it from all transient sources. In the latter case, the MOV can be conveniently mounted to the same SSR output terminals as the load wiring. With the impedance of the load in series with the MOV to limit current, a 30 joule unit is usually adequate for brief spikes and also small enough to be supported by its own leads.

If a MOV is connected directly across the power line, the current limiting impedance will only be that of the power generating source plus the wiring. In order to absorb the possibility of high energy line transients from such a low impedance source, the larger panel mount (300 - 600 joule) variety of MOV may be required. The greater expense of such a device might be justified in that suppression across the line is required in one place only.

Individual MOV specifications should be consulted for precise information regarding energy absorption, clamping properties and physical size, since the relationships of these parameters will vary from one manufacturer to the next.

Fuses

Semiconductor fuses are usually used in conjunction with SSRs and are specialist fuses designed to protect while operating at close to their full ratings.

They are sometimes referred to as current limiting fuses, providing extremely fast opening, while restricting let through current far below the available fault current that could destroy the SSR. Although these fuses are not low cost, they do provide a means of protecting SSRs against high current overloads where survival of the SSR is of prime importance.

The following are the main parameters used in the selection of a semiconductor fuse:

- Fuse voltage rating
- Fuse current rating
- Available system fault current
- Fuse peak let through current
- Fuse total clearing (or let through)
- Surge withstand capability of the SSR

SSR Applications

The diagrams in this section are conceptual illustrations of just a few typical SSR applications. They are intended as design guides to steer the user in the right direction and to stimulate further design ideas. Some of the diagrams provide problem solving or circuit protection and others enhance relay operation.

Latching SSR (Fig. 13)

Momentary push-button control allows the SSR to self-latch for on-off, stop-start operations. It may be similarly configured for DC in/DC out type SSRs.

Resistor R1 (10 kΩ) is required to prevent line short only if alternate (NO = normally open) switch is used.

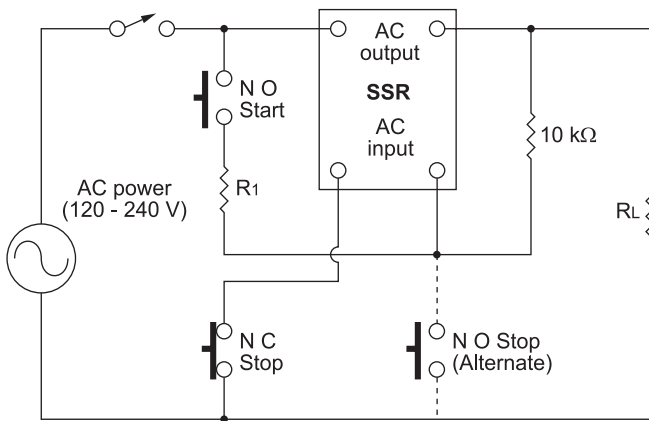

Fig. 13: Latching SSR circuit

Motor starter switch (Fig. 15)

Initial locked rotor current flowing through R1 creates a voltage that, when rectified and filtered, turns on the SSR, which in turn activates the start winding. As the motor comes to speed, the voltage across R1 is reduced until the start winding is de-energized.

The SSR should have a voltage rating approximately twice that of the applied line to withstand overvoltage generated by the current LC.

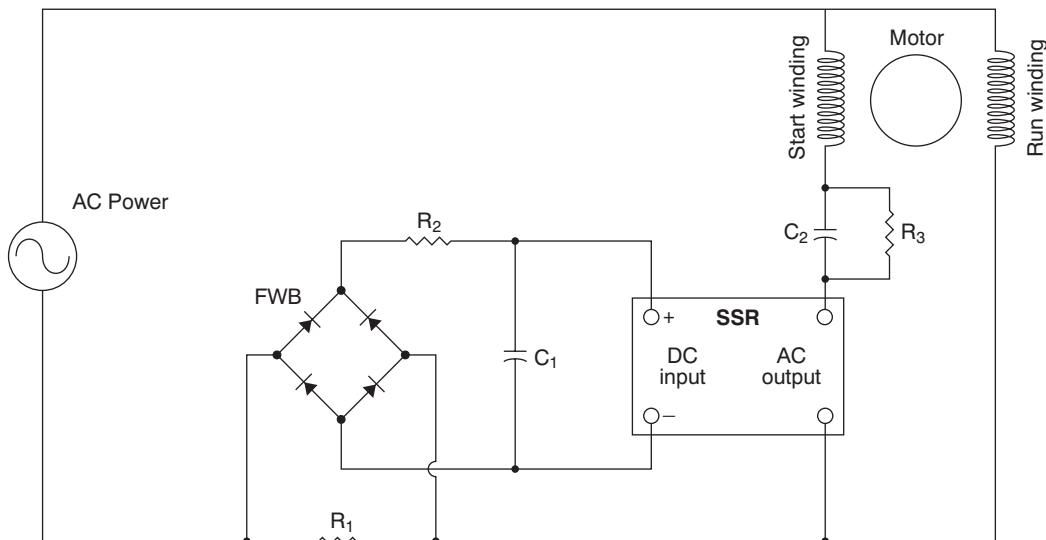

Fig. 15: Motor starter switch

Latching SSR with short-circuit protection (Fig. 14)

Push-button control as in the previous example, but R2 is tailored to limit the load shorting current to SSR surge rating (for turn-off time), thus preserving SSR while the control signal is removed. Latching characteristic permits lock-out until the circuit is reset.

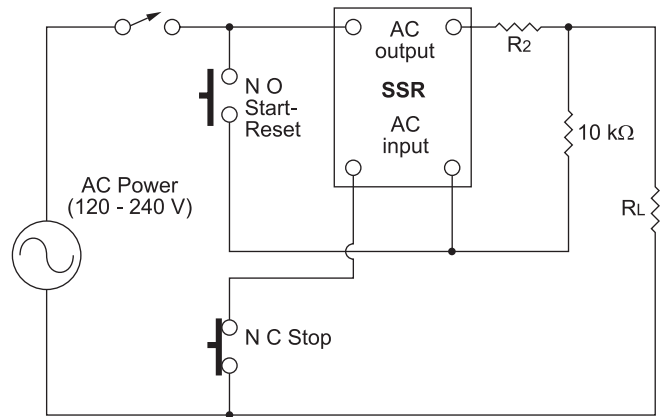

Fig. 14: Latching SSR with short-circuit protection

Functional Three-phase switch for Three-wire system (Fig. 16)

Two SSRs may be used to control a Y or a delta load in a three-wire system. A third SSR would be required in phase C if the centre of the Y load were grounded, as in a four-wire system. SSR voltage rating must be greater than line to line voltage for three-wire systems and line to ground voltage for four-wire systems (with neutral ground).

SSRs are most commonly used in three-phase applications to control motors, where their current ratings depend as much on locked motor current as they do on normal run current and proper heat sinking. Where a motor rating is not given, a minimum SSR current value can be estimated from the device surge curves, using the general rule of six times the motor run current for one second. This value must also be commensurated with thermal and lifetime requirements.

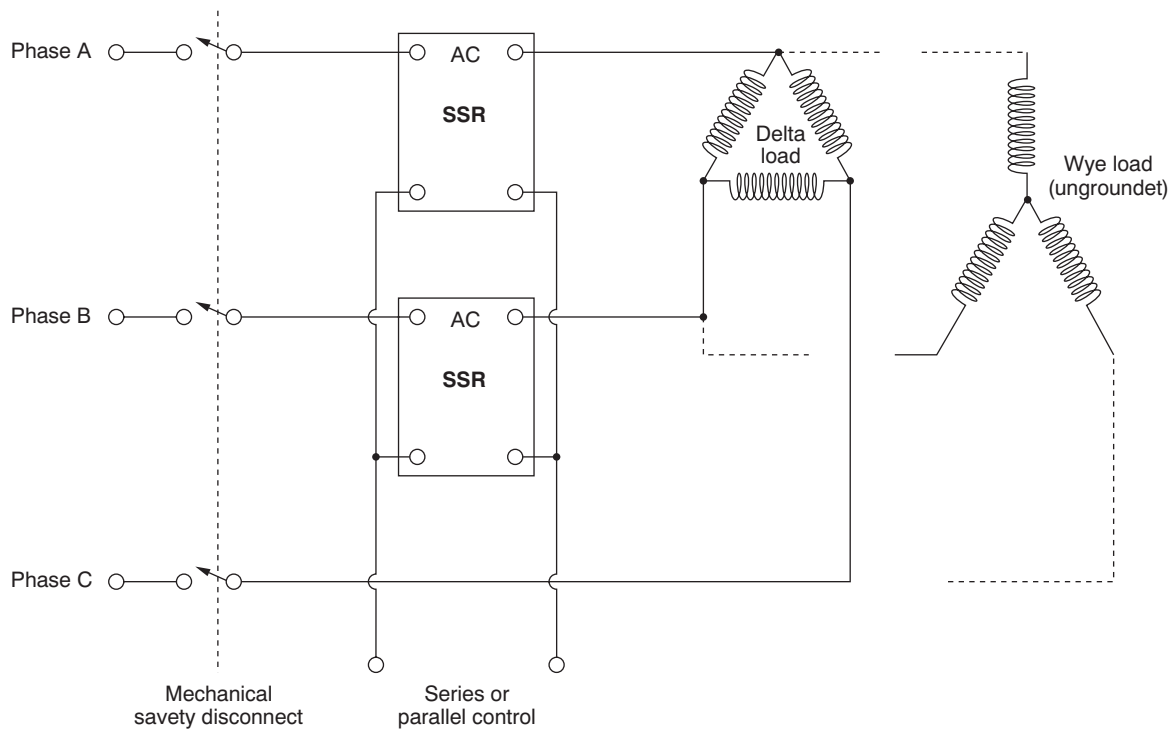

Fig. 16: Functional three-phase switch for three-wire system

Three-phase motor reversal (Fig. 17)

For ac SSRs can provide a reversing function for a three-phase motor, using the drive logic suggested. The half cycle time delay before enabling the drive, in either direction, prevents make before break which would result in a line to line short. Two opposing SSRs (nos. 1 and 4, or 2 and 3) could still mistrigger simultaneously due to dv/dt or high voltage transients; therefore, resistors R1 through R4 are inserted to limit the resultant surge current. The sum of any two resistors plus the source impedance should limit the shorting current to less than a peak one cycle surge rating of each relay.

Semiconductor type fuses should be chosen to permit such a condition for one cycle and open as soon as possible thereafter. SSRs should have a transient (blocking) rating equal to twice the line to line voltage to withstand the combined line and back EMF generated at the moment of reversal.

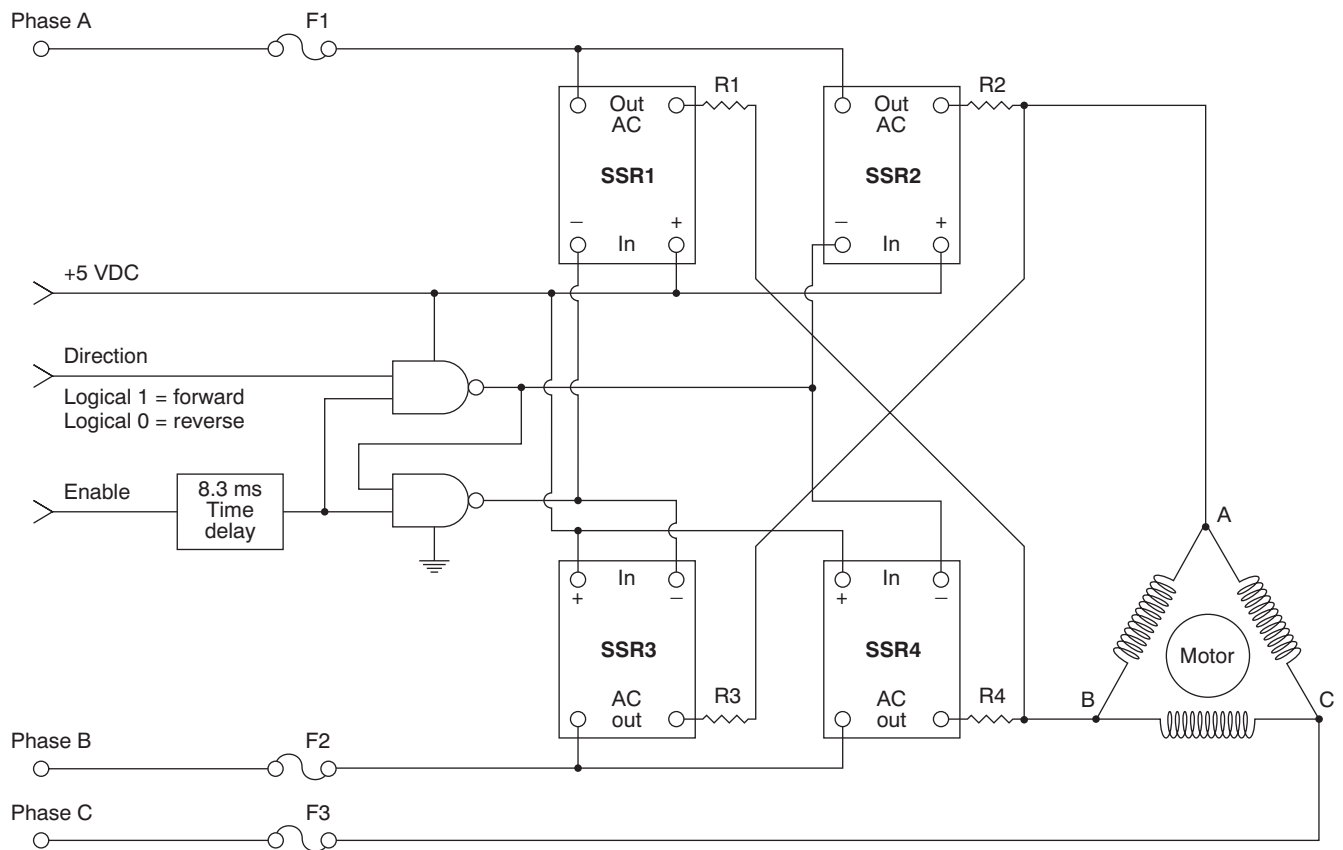

Fig. 17: Three-phase motor reversal

Reversing motor drive for dc Motors (Fig. 18)

In this configuration, four dc SSRs are used for motor reversal from a single power supply. The time delay before enabling the drive in either direction must be greater than the SSR turn-off time to preclude the possibility of a hazardous make before break condition. Internal reverse diodes or zeners in the SSRs will suppress inductive transients across the low impedance of the power supply. If no internal suppressors exist, a reverse diode should be installed across each SSR output or, alternatively, SSRs with blocking ratings at least twice that of the supply voltage may be used. The circuit should be current limited or fused to protect the wiring in the event of a short circuits.

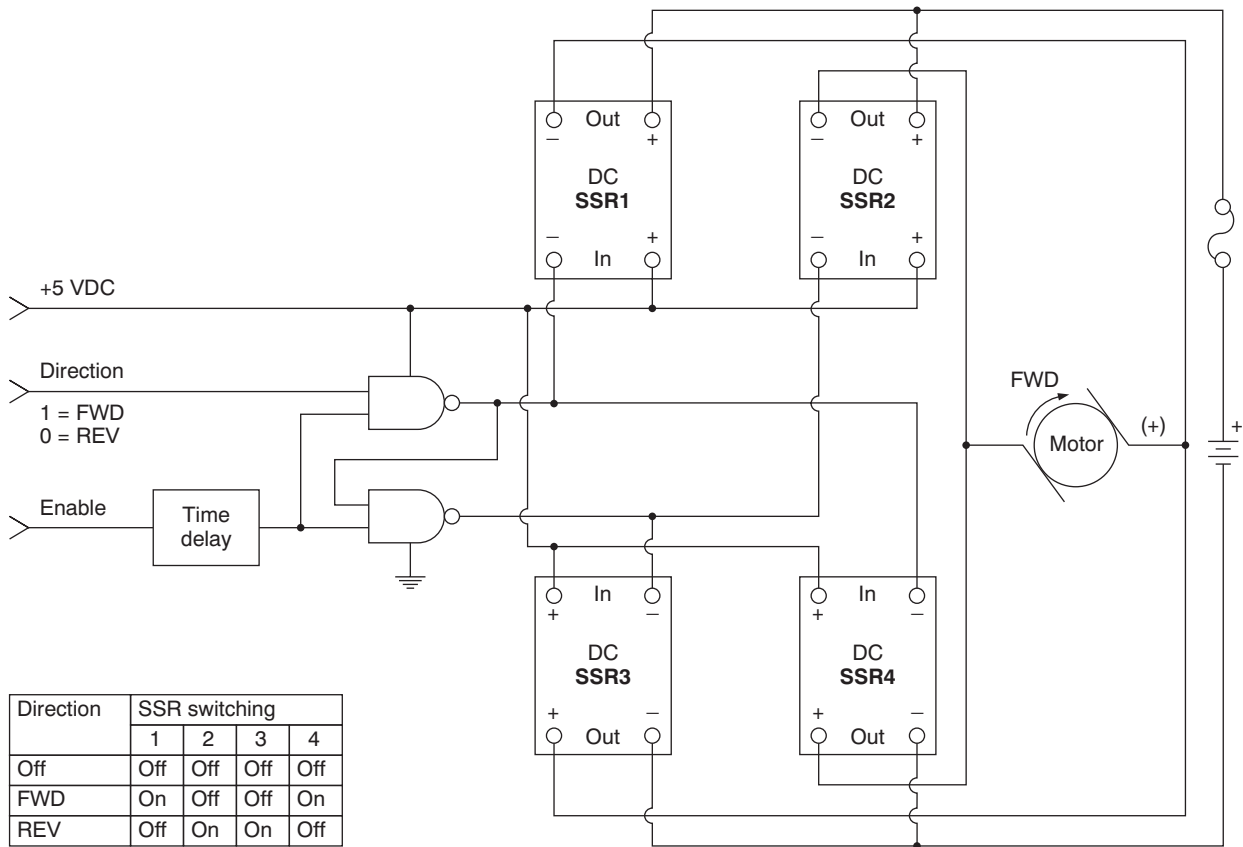

Fig. 18: Reversing motor drive for DC motors

Paralleling SSRs (Fig. 19)

SSRs with MOSFET outputs are self balancing and easily paralleled, whereas most others with bipolar or thyristor outputs require special attention. Ideally, the forward voltage drops should be matched to achieve thermal balance and lowest dissipation; alternatively, balancing resistors (R_x) are used to force current sharing as shown, For example, with 40 amps allowed through SSR1, SSR2 must carry 32 amps.

Assuming $V_1 = 1,3$ volts and $V_2 = 1,5$ volts (worst case):

$$R_x = \frac{\Delta V}{\Delta I} = \frac{V_2 - V_1}{I_1 - I_2} = \frac{1,5 - 1,3}{40 - 32} =$$

$$\underline{\underline{R_x = 0,025 \text{ Ohm}}}$$

Thus producing a total voltage drop of 2,3 V.

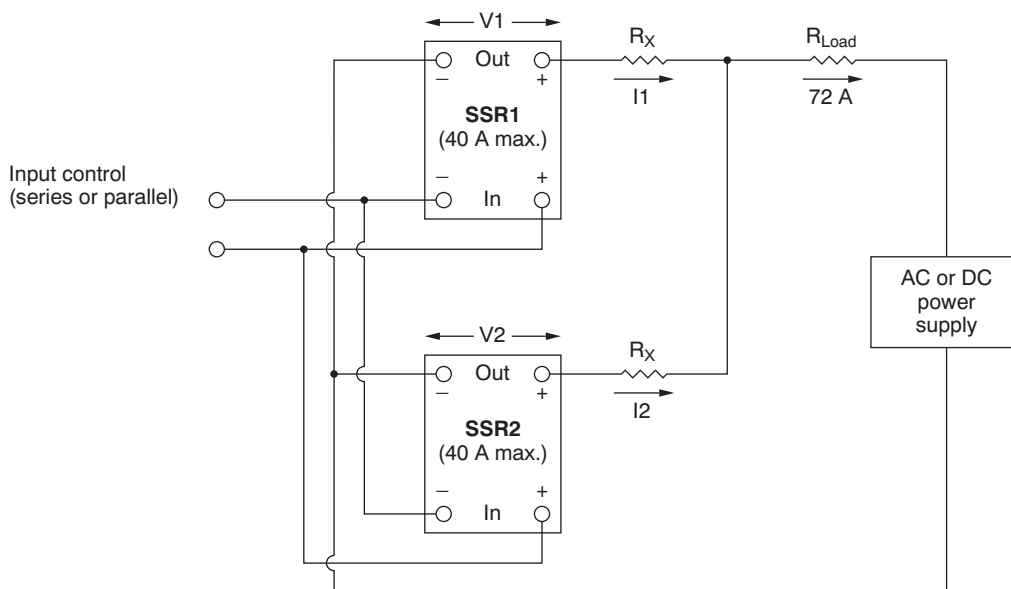

Fig. 19: Paralleling SSRs

For zero voltage turn-on thyristor types, either one of the SSRs must be capable of handling the initial full load surge alone because of a possible half cycle mismatch. Thyristor SSRs have additional turn-on problems that can prevent paralleling.

Transformer Tap switching (Fig. 20)

If a momentary interruption in power is acceptable, a time delay on operate is suggested to prevent overlap and the resulting high current surge from a shorted winding. Two times R_x plus the winding resistance must be sufficient to limit the surge current to the one cycle surge rating of the SSRs.

As an additional precaution, the SSR blocking (breakdown) voltage should exceed the main winding voltage plus the highest tap voltage. For multi-tap switching the SSRs are generally logic driven dc controlled ac output types without special requirements. For Figs. 36B and C, they are 250 Vac output with 120 Vac input for SSR1 and 240 Vac input for SSR2 in each case. An important requirement of SSR2 is that it must be off below the highest expected 120 Vac line swing, say 150 Vac. When SSR2 is off, SSR1 will be on and vice versa, thus activating the appropriate winding.

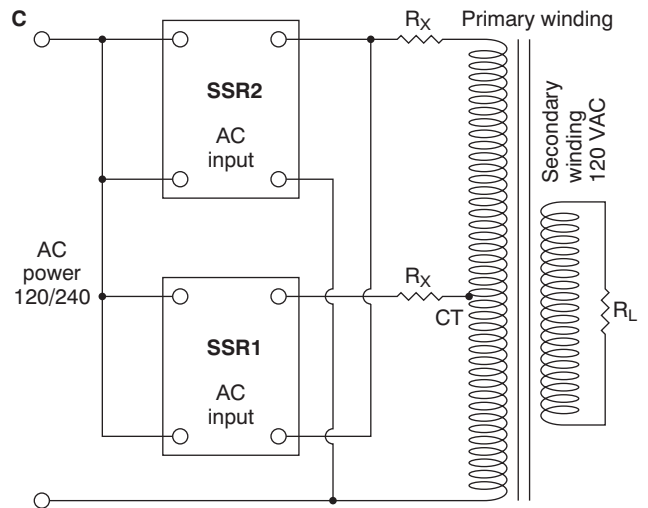
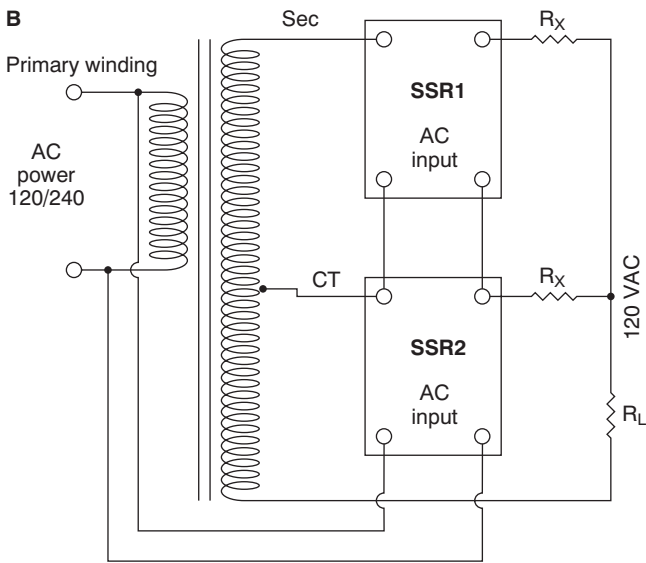
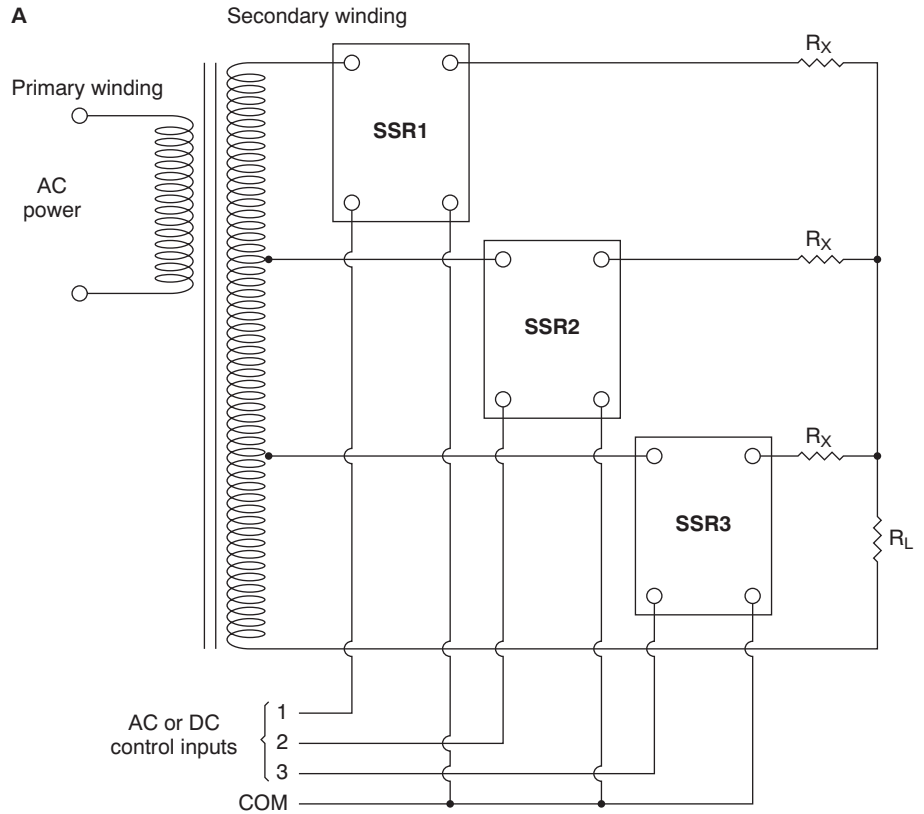

Fig. 20: Transformer tap switching

Testing the SSR (Fig. 21)

Many of the tests required to verify SSR performance are inherently hazardous and caution should be exercised, using adequate safeguards for the personnel conducting such tests.

Possibly the simplest of all field tests that can be made to determine proper function of an AC SSR is by means of a 3 volt battery, a light bulb, and a piece of insulated wire. This simple go/no-go test is illustrated by Fig. 21.

A more complete performance check might include operating the SSR in position with its actual load, while exercising the

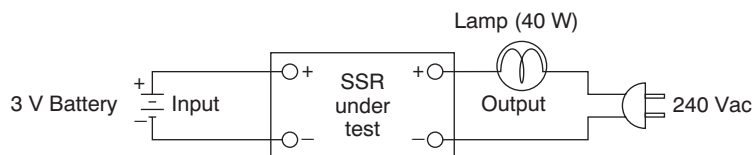

Fig. 21: Simple go/no-go SSR test

system installation functionally through all of its specified environmental and power combinations.

When connecting test equipment directly to the power circuit of an SSR output, protective fusing would be a wise precaution. Also remember that with some equipment such as an oscilloscope, the case must be „floated“ (ungrounded) and may be at line potential. In some test circuits an isolated current probe or an isolation transformer can be used to avoid this hazard. The output functions of an SSR should not ever be checked by a multimeter in the ohms mode, since the minimum voltages and bias currents necessary for proper SSR operation are not present, thus producing erroneous readings.

Glossary of terms

Ambient temperature range. The surrounding air temperature limits, usually given for both operating and storage conditions. The maximum operating temperature may require close consideration by the thermal dictates of heat dissipation and the possible requirement of a heat sink.

Anode - Connection of a thyristor. High potential terminal on an SCR. Positive in respect to gate and cathode when conducting (blocking when negative).

Base. The control terminal of a bipolar transistor.

Bipolar. Generally used to describe a transistor type in which a dc current flow between collector and emitter is modulated by a smaller current flowing between base and emitter. The gain of the transistor relates to the ratio of these two current defined as beta or hfe in common-emitter configurations.

Bistable. A two state device that will remain in its last operated state after control power is removed (e.g. latching relay).

Blocking voltage. Maximum allowable standoff voltage before breakdown.

Breakdown (Breakover). The point at which blocking capability in an SSR collapses as voltage is increased beyond its maximum (transient) rating.

Capacity. The ability to store an electrical charge. Also given as an SSR isolation parameter, measured input to output, or both to case, provided as a means of determining high frequency noise coupling.

Cathode. SCR terminal associated with gate terminal. Negative in respect to anode when conducting.

Collector. A main current terminal and also high voltage terminal of a transistor relative to the base and emitter.

Control voltage. Specified as a range of voltages which, when applied across the SSR input terminals, will maintain an on condition across the output terminals.

di/dt. Maximum rate of rise of on state load current that an SSR can withstand without damage. A characteristic of thyristors used in ac SSRs.

du/dt (rate of rise of voltage) in blocking state (static). Maximum rate of rise of voltage applied across the output terminals that the SSR can withstand without turning on. A characteristic of thyristors used in ac SSRs.

Emitter. A main current terminal of a transistor, also associated with the base terminal and its control current.

FET. Field Effect Transistor. Principle of operation differs from that of bipolar types. Voltage applied between gate and source terminals modulates the device resistance to current flow between drain and source terminals, by means of a field set up in the channel region.

Holding current. The minimum (load) current required to maintain a thyristor in its conducting state.

I²t (Maximum). Nonrepetitive pulse current capability of SSR given for fuse selection. Expressed as „ampere squared seconds“ with typical half cycle pulse width.

Inductance. An electrical property which can oppose a current change and also store a charge. The unit of inductance is called the Henry [H].

Input current (Maximum). Current drain on the control source at specified SSR input voltages and on-off conditions.

Input Impedance/Resistance. Minimum effective SSR input resistance at a given voltage which defines input power and sensitivity.

Instantaneous turning on. After applied control power the SSR switches to on independently of the momentary phase-angle.

Insulation Resistance (Minimum). Resistive value usually measured at 500 volts dc, input to output, or both to case.

Leakage current. The current conducted through the SSR output terminals, in the off state.

Load Current (Maximum). The maximum steady-state load current capability of an SSR, which may be further restricted by the thermal dictates of heat sink and ambient temperature conditions.

Load Current (Minimum). The minimum load current required by the SSR to perform as specified.

Load voltage (Maximum). The range of minimum to maximum mains voltage, that can be applied to the outputs of the SSR.

Maximum capacity input to output. Maximum value of capacitive coupling between control terminals and power output terminals.

Maximum overcurrent (not repetitive). Maximum allowable SSR momentary current flow for a specific time duration. (Typically expressed as an RMS value for a one second duration).

MOSFET. Metal Oxide Semiconductor Field-Effect Transistor. The control electrode (gate) is generally isolated from the source electrode by a layer of silicon oxide. A voltage applied between the gate and the source will provide a current flow between drain and source.

MOV. Metal Oxide Varistor, commonly used with ac SSRs to suppress bidirectional voltage-dependent resistive characteristic that drop rapidly with increasing voltage.

MTBF. Mean Time between failure.

On State Voltage (Maximum). The peak voltage that appears across the SSR output terminals at full rated load.

Phase control. Turn-on of a nonzero switching SSR (each half cycle), at a phase angle determined by the control signal source.

Power dissipation. The maximum average power dissipation [watts] resulting from the effective voltage drop (power loss) in the SSR output semiconductor.

RMS Voltage (Root-Mean-Square). The value of alternating voltage (ac) that would produce the same power dissipation as continuous voltage (dc) in a resistive load. For a sine wave, RMS is 0,707 times the peak value.

Semiconductor fuse. A specially constructed fast-acting fuse capable of protecting semiconductor devices, with opening times typically less than 10 milliseconds.

Snubber. A resistor-capacitor combination placed across the SSR output terminals to control dv/dt and transients in thyristor circuits.

Solid-State-Relay, SSR. Isolated On-Off-Switch composed of non-moving electrical parts (i.e., primarily semiconductors, transformer and passive components).

Surge current. The maximum allowable SSR momentary current flow for a specific time duration. (Typically specified as a peak value for one line cycle for ac).

Thermal resistance ($R\theta$). Expressed in „degrees celsius per watt“ [$^{\circ}C/W$]. This value defines the temperature gradient in the path between the power generated in the output SSR semiconductor and the final dissipating medium (heat sink/air).

Thyristor. A semiconductor bistable device comprising three or more junctions (PNPN, etc.). The generic name for a family of gate controlled switches including SCRs and triacs.

Transient. Brief overvoltage or overcurrent excursion from normal condition.

Transient overvoltage. The maximum allowable brief excursion of applied voltage that an SSR can withstand without damage or malfunction while maintaining its off state.

Transistor. Generally a three-terminal semiconductor device with dc current flow between two terminals modulated by the third. A bipolar transistor is essentially a current-controlled device, while a field-effect transistor is a voltage-controlled device.

Triac. Bidirectional semiconductor of the thyristor family. Performance is similar to that of an inverse pair of SCRs, triggered by a single gate electrode.

Turn-off time (Maximum). The maximum time between the removal of the turn-on control signal and the transition of the output device to its blocking (off) state.

Turn-off voltage. The voltage applied to the input at or below which the output is guaranteed to be in the off state.

Turn-on time (Maximum). The time between the application of a turn-on control signal and the transition of the SSR output to its fully conducting state.

Turn-on voltage (Must Operate). The voltage applied to the SSR input at or above which the output must be in the on state (normally open).

Varistor. See Metall Oxid Varistor (MOV).

Zero Voltage Turn-On. The maximum (peak) off state voltage that appears across the SSR output terminals immediately prior to initial turn-on, following a turn-on control signal.

Accessories

Content

Electronics empty-casings

Electronics empty-casings and plug-plates

LG 121, SP 11/101, LG 220, SP 11/201 2

Edition 02.09

Subject to technical changes and amendments to
technical specifications at any time

Electronics empty-casings and plug-plates

LG 121, SP 11/101, LG 220, SP 11/201

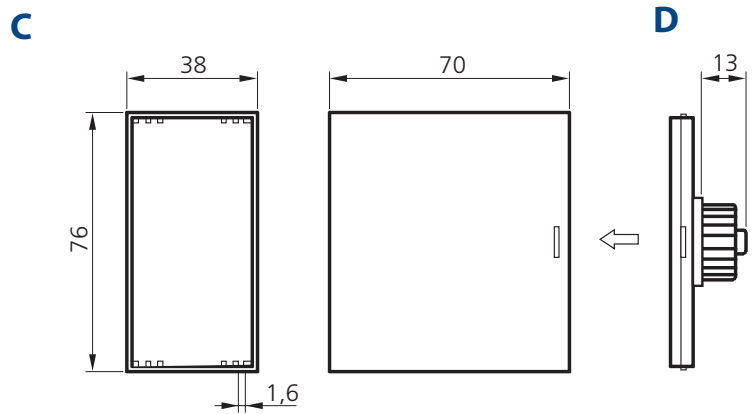
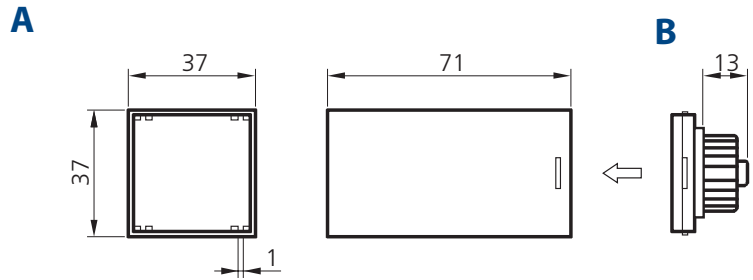

General data

Empty-casings with guide-grooves for printed circuit board, 11-poles, pluggable.

An individual label can be mounted on front-side.

Case Makrolon

Color grey/blue

Plug-plate Fiberglass reinforced polyester PPO modified (Noryl)

Protection class IP 40

Plug-in socket see chapter 5

Description

Description	Type	Dimension	Article no.
Empty-casing (for printed circuit board 64 x 33 x 1 mm)	LG 121	A	41930032
Plug-plate 11-poles	SP 11/101	B	41930034
Empty-casing (for printed circuit board 72 x 64 x 1,6 mm)	LG 220	C	41930006
Plug-plate 11-poles	SP 11/201	D	41930010

(Order data see chapter 1)

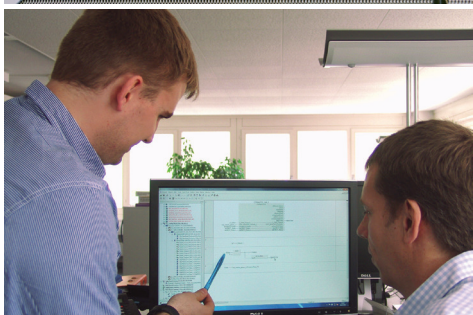
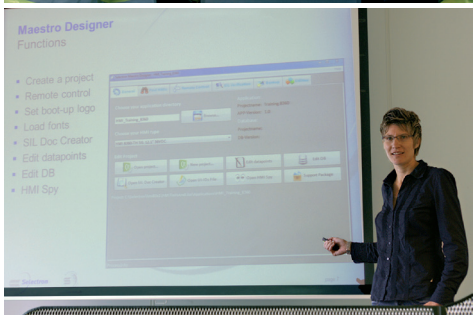

DO YOU HAVE ANY QUESTIONS ABOUT AUTOMATION?

WE ARE JUST A CALL AWAY

Selectron Systems AG

Bernstrasse 70
3250 Lyss
Switzerland
Tel: +41 32 387 61 61
Fax: +41 32 397 61 00
www.selectron.ch



 **KNORR-BREMSE**

 **NEW YORK AIR BRAKE**

 **IFE**

 **MERAK**

 **MICROELETTRICA**

 **SELECTRON**

 **KIEPE ELECTRIC**

 **EVAC**

 **ZELISKO**

 **RAILSERVICES**