

# Central Processing Units xCPU 203-TW

## Safety Information and Instructions

### IMPORTANT

To avoid personal injury and device damage, the following notes and instructions must be followed.

- Please read the Module Manual of the specific product carefully before using the product. The Manual and all corresponding documents can be downloaded from the Selectron Information Platform Symphony Suite. For registration and download, visit <http://cockpit.selectron.ch/download>.
- The technical data in this document may be subject to change. Always consult the Module Manual for the final and most up-to-date information.
- Allow only appropriately trained personnel to handle the devices and pay attention to the ESD protection measures.
- Usage restriction: The designated product may only be used in an industrial environment (Class A product) in accordance with specifications in the manuals.
- To ensure a ground connection, a metallic top hat rail must be used. Due to the grounding function of the top hat rail, it must neither be plastic-coated nor anodized. In addition, the top hat rail must be grounded with a large surface area and low-impedance connection.
- To avoid the risk of destroying a module, it must never be mounted or removed under live voltage.
- Before supplying any voltage, make sure that the power supply connector is connected in order to follow the EMC standards.
- For M12 Ethernet connections, the cables and the connection plugs must be shielded.
- For D-sub MVB connections on Selectron modules, the cables and the connection plugs must be shielded.

## General Information

This document is applicable for the following Selectron products:



**CPU 203-TW** (Art. No. 44410003) Central Processing Unit



**SCPU 203-TW** (Art. No. 44410006) SIL Central Processing Unit

### Manufacturer

Selectron Systems AG | Bernstrasse 70 | 3250 Lyss | Switzerland | [www.selectron.ch](http://www.selectron.ch)

### Package Content

The package contains:

Article	Number
Device CPU 203-TW or SCPU 203-TW	1

Available Accessories see [Page 6](#).

### State of Delivery

In the state of delivery, the xCPU has no fixed IP Address assigned to it. The xCPU is delivered with an initial Maintenance System installed. Please refer to the Module Manual for further information.

# Central Processing Units xCPU 203-TW

## Technical Data

Environmental conditions	
Degree of Protection (IP Code according to IEC 60529)	IP20
Operating temperature according EN50155	-40...+70 °C
Storage temperature	-50...+85 °C
Dry Heat test, extended Temperature Range (10 Minutes); EN50155:2021	+95 °C
Operation altitude (max. with derating)	5000 m. a. s. l.
Operation altitude (no derating)	2000 m. a. s. l.

Power Supply US	
Nominal Supply Voltage (US)	24 ... 110 V DC
Limit Values (UN * 0.7) - (UN * 1.25)	16.8 ... 138 V DC
Limit Values (UN * 0.6) - (UN * 1.4) < 1s	14.4 ... 154 V DC
Reverse polarity protection	yes
Power dissipation (typical, standalone operation)	6 W
Power dissipation (max., standalone operation)	10 W

## Power Supply

**WARNING**



Dangerous voltage (direct voltages above 70 V DC)

**Risk of death by electric shock**

- Always disconnect the device from the power source before servicing.
- Do not operate the device with damaged cables or plugs.
- Ensure the power supply matches the voltage rating indicated on the device label.
- Only qualified personnel should perform maintenance or installation.
- Keep the device away from water or moisture to prevent electrical hazards.

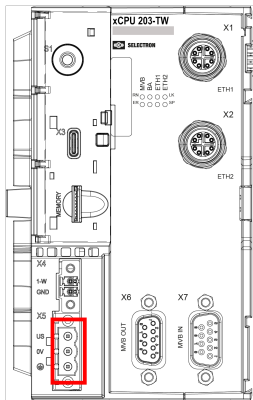

Purpose/Features	Supply voltage of 24...110 V DC to the module
Labeling on device	X5
Socket Type / Pitch	3-pin / 5.08 mm
Connector/Plug Type	TBA 250/PS
Fixation	2 × Screw M2.5
Torque	0.25 Nm ... 0.3 Nm

Pin	Signal	Description
1	US	Supply Voltage 24...110 V DC
2	0V	Reference point
3	Earthing	Protective ground

### Grounding

Functional grounding is provided through the device housing. The earth connection at the power supply connector serves exclusively as protective grounding.

### Power Consumption

The typical power consumption of the module is typically 6 W (max. 10 W).

# Central Processing Units xCPU 203-TW

## Ethernet Interfaces X1/X2

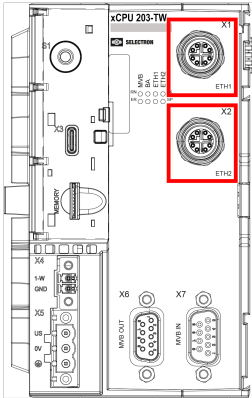

Purpose/Features	Programming + Data Interface, 1 Gb-Ethernet (Gigabit Ethernet)
Implementation / Labeling	X1: Ethernet Interface 1 / X2: Ethernet Interface 2
Socket Type	Push-Pull (M12 Screw compatible), X-coded
Connector/Plug Type	CAM 201 / CAM 202
Fixation	Push-Pull tool-free fast locking

## Dimensions

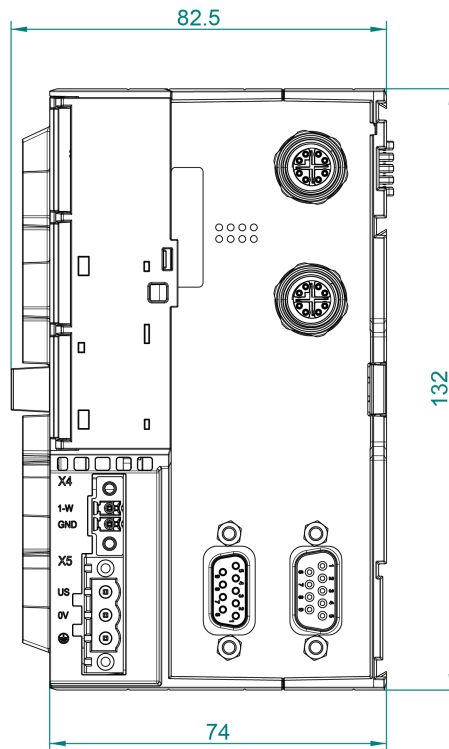
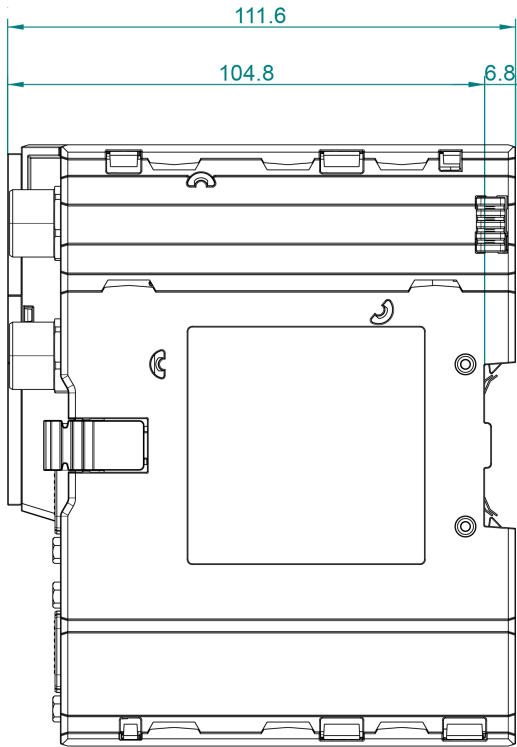

# Central Processing Units xCPU 203-TW

## Installation / Mounting

### Required tools and accessories:

- Slotted screwdriver (3.0 × 100) for the fixation of the end bracket.
- End bracket EBS 270/TS for the fixation on the left side of the module.

**i NOTE**

For the wiring it is recommended to temporarily place a flat plate on the upper ventilation slots as protection against the ingress of foreign materials (e. g. insulation residues). After wiring, the plate must be removed again for proper operation (air passage must be free during operation).

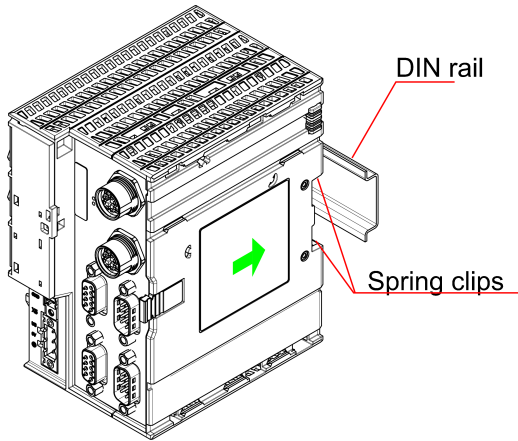

Hook the module with the upper spring clip (on the backside) on the DIN rail. Slightly push the lower part of the module until the lower spring clip snaps onto the DIN rail.

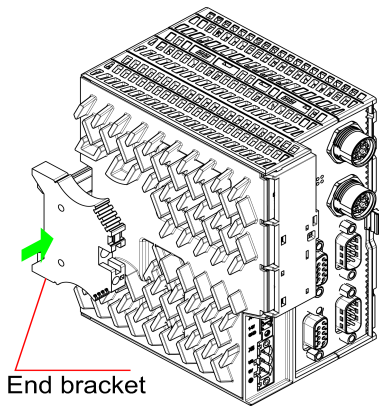

From the left side, mount the end bracket on the DIN rail and move it to fully touch the housing of the module. Use a slotted screwdriver (3.0 × 100) to tighten the fixation screw of the end bracket.

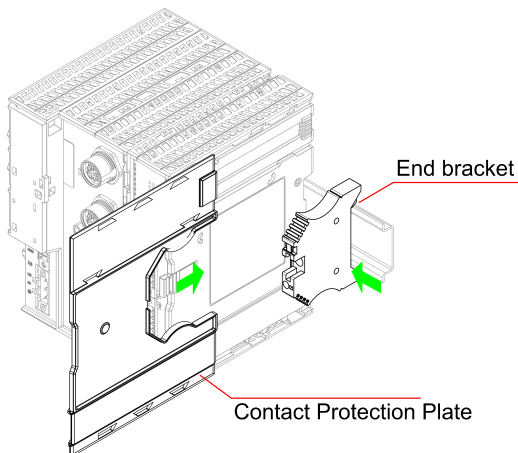

In case the xCPU is operated in standalone mode, mount the Contact Protection Plate on the right side of the xCPU.

**i NOTE**

Please refer to Module Manual for complete and detailed installation instructions.

# Central Processing Units xCPU 203-TW

## Deinstallation

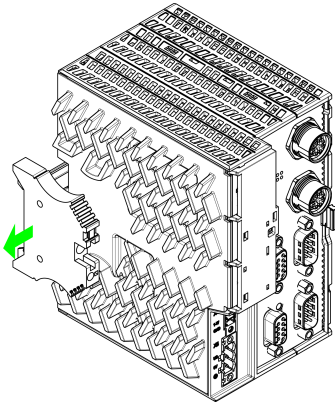

Turn off the Power Supply of the module to ensure absence of voltage remove the power supply connector.  
Remove all Ethernet and MVB connectors from the module.  
Remove the end bracket on the left side of the module.

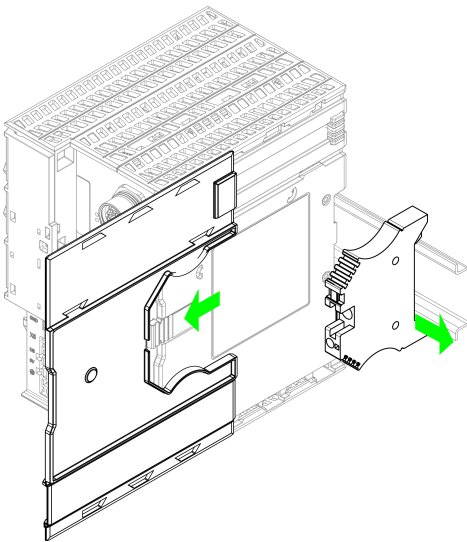

Remove the end bracket and Contact Protection Plate on the right side of the module.

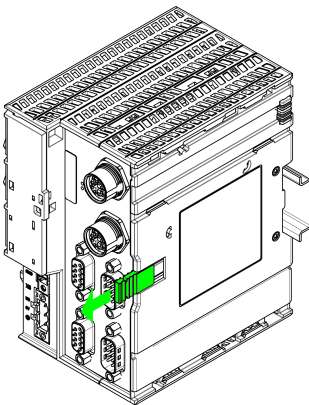

Pull the Lock/Unlock Lever and remove the module from from its DIN rail.

### **i** NOTE

Please refer to Module Manual for complete and detailed installation instructions.

# Central Processing Units xCPU 203-TW

## Storage and Disposal

### Storage of the Equipment

The rooms in which the **packaged** equipment is stored must have the following properties:

- well ventilated and vibration free
- Protection against moisture, frost, heat, dust, and sand (for temperature values, see the Technical Data chapter)
- Protection from vermin, rodents, termites, etc.
- the relative humidity must not fall below 20% and must not exceed 75%
- the relative humidity must not change by more than 15% within 24 hours

### Decommissioning and Disposal

At the end of their service life, the corresponding modules must be replaced with new ones in a professional manner and the old ones disposed of according to local, regional and national regulations.

The modules and components comply with EU Directive 2011/65/EU RoHS.

Electronic waste must be disposed of according to the current legal regulations of the respective countries. In addition, it is possible to send old equipment to Selectron Systems AG for disposal.

## Available Accessories

Product Name	Art. No.	Description
TBA 250/PS	44470009	Connection terminal block with 3 positions (US, 0V, PE) for Power Supply, Push-in spring connection, single-wire, Screw locking mechanism
TBA 260/1-W	44470010	Connection terminal block with 2 positions (1-W, GND) to be used for Place-bound Coding Unit (1-Wire), Push-in spring connection, single-wire, Screw locking mechanism
EBS 270/TS	44470011	End bracket Screwed, TS-35
CAM 201	44470016	Ethernet Connector M12 (X-coded) Push-Pull, straight
CAM 202	44470017	Ethernet Connector M12 (X-coded) Push-Pull, angled 90°
CAM 806-T	44130179	Ethernet Connector M12 (X-coded), rapid interlock, straight
ECA 803-T	44130178	Ethernet adapter cable, M12/RJ45, X-coded, 2 m
CBA 201	44470015	Cable Bundling Aid
CPP 201	44470012	Contact Protection Plate
SKT 201-T	44470020	Seal for cover flap for xCPU, plastic express seals 9 mm black, galvanized wire
FMC 201-T	44470021	Flash Memory Card 16 GB, microSD, Flash-Type 3D TLC NAND, pSLC
FMC 202-T	44470022	Flash Memory Card 32 GB, microSD, Flash-Type 3D TLC NAND, pSLC
FMC 203-T	44470023	Flash Memory Card 64 GB, microSD, Flash-Type 3D TLC NAND, pSLC

Further accessories for the MVB connection can be found in the corresponding Module Manual.